

CRANBROOK LOOM RADDLE MOUNT FOR LOOMS WITH DOUBLE BACK BEAM

ASSEMBLY INSTRUCTIONS

PARTS LIST

- 2 – side rails
- 2 – raddle blocks
- 2 – 2" hex head bolts
- 8 – black knobs
- 8 – nylon washers
- 2 – 1/4" washers
- 2 – barrel nuts

TOOLS

- Flat screwdriver

ASSEMBLY

- Find the slots at the end of the side rails and mount this end to the rear upright of the loom frame. Use the holes located just above the steel beam and secure with a black knob and washer.
- Attach the other end with a black knob and washer at the mid upright.
- Attach the raddle blocks to the raddle. The inserts on the blocks should face away from each other. Insert a barrel nut into the raddle block, put a hex head bolt through the raddle, into the raddle block, and tighten it into the barrel nut. You can use a screwdriver to turn the barrel nut to align it with the bolt.
- Secure the raddle blocks to the side rails. Align the inserts in the raddle blocks with one of the sets of holes in the side rail. Secure the raddle blocks to the side rails with washers and black knobs, screwing the knobs into the inserts in the raddle blocks.

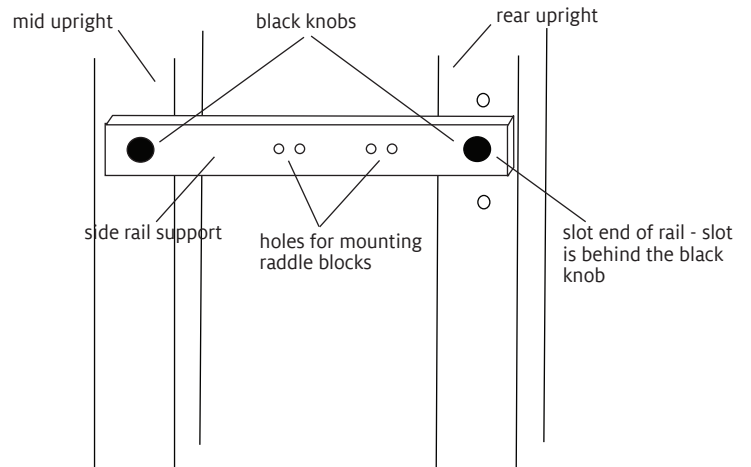

FIGURE 1 - RIGHT SIDE OF LOOM

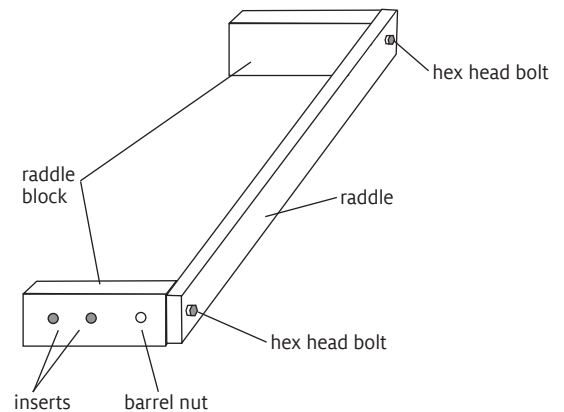

FIGURE 2 - ATTACH RADDLE BLOCKS TO RADDLE



Find out more at schachtspindle.com
Schacht Spindle Company 6101 Ben Place Boulder, CO 80301
p. 303.442.3212 f. 303.447.9273

© 2014 Schacht Spindle Company, Inc.