

MATCHLESS SINGLE TREADLE SPINNING WHEEL

INSTRUCTIONS, MAINTENANCE & WARRANTY



Find out more at schachtspindle.com

Schacht Spindle Company 6101 Ben Place Boulder, CO 80301

p. 303.442.3212 f. 303.447.9273

© 2015 Schacht Spindle Company, Inc.

01.15

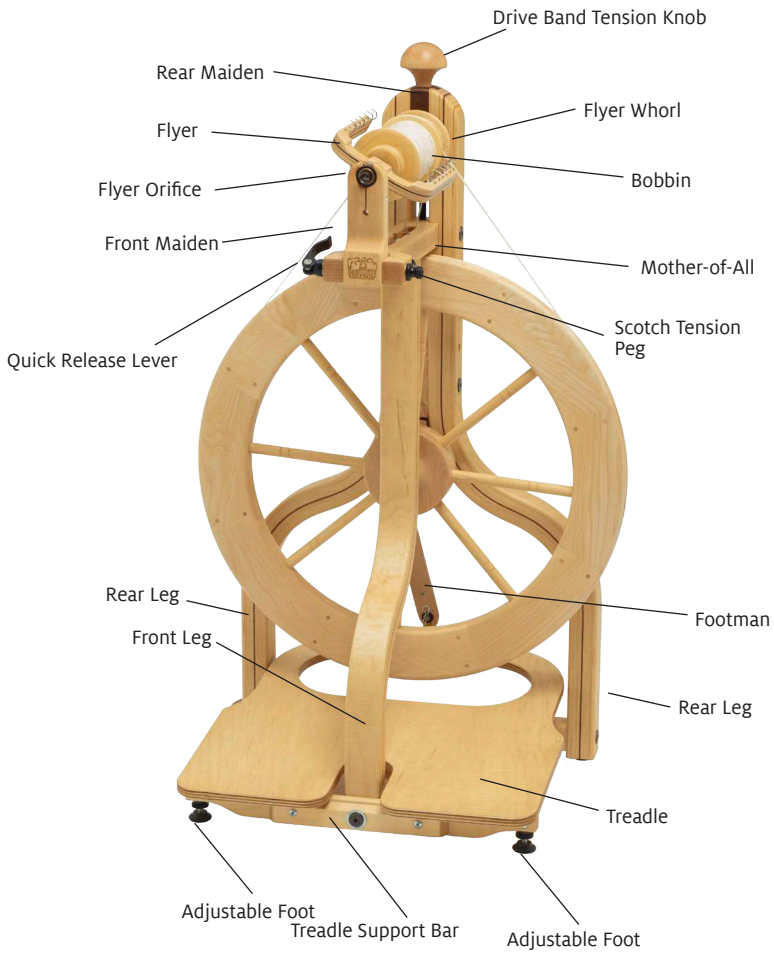

SINGLE TREADLE WHEEL

We are pleased that you have chosen one of our Schacht Spinning Wheels, and trust that it will give you many fruitful hours of spinning. We have taken great care in the design of our wheels to make them efficient and sturdy as well as aesthetically pleasing. Our wheels are constructed using traditional woodwork- ing joinery, following the concept that form follows function. We feel that good design and quality craftsmanship, along with regular maintenance, ensures that your wheel will endure.

Each part has been specially designed with function in mind. During manu- facturing, every part is inspected for quality, and the final assembly has been done by a skilled craftsperson. Should you have any questions about the qual- ity of the work or the materials, please do not hesitate to contact your dealer or our customer service department directly.

Your Schacht Spinning Wheel is a precision tool, having many moving parts that require regular care and maintenance. The better you understand your wheel, the more able you will be to take advantage of its many features.

Please read this booklet before you start spinning on your wheel.

UNPACKING YOUR WHEEL

Unpack the accessory boxes and make sure you have all the parts.

Large Box:

- 1 – Lazy Kate
- 3 – bobbins
- 3 – Lazy Kate bobbin rods
- 1 – carrying strap

in small bag:

- 1 – threading hook
- 1 – 4mm hex wrench
- 1 – 5mm hex wrench
- 3 – black retainer rings for bobbin rods
- 1 – Scotch tension brake spring and cord
- 1 – extra length of drive cord
- 10 – 1/4" trusshead screws
- 2 – 1" trusshead screws

Small box:

- 1 – bobbin
- 1 – flyer
- 1 – flyer whorl
(2nd whorl is attached to the back of the rear maiden)
- 2 – cotter pins
- 2 – treadle yoke clevis pins
- 4 – nylon washers

Wood Parts:

- 1 – treadle with treadle yoke attached to the treadle support bar

REQUIRED TOOLS

- Phillips screwdriver

ATTACHING THE TREADLE

Remove the leg bolt, washer and short rod from the front leg. Remove the short rod from the leg bolt. Insert the bolt with the washer through the hole in the middle of the treadle support brace. Place the short rod on the leg bolt and insert the leg bolt into the front leg. Align the short rod with the slot in the front leg. With the 4mm hex wrench fasten the leg bolt into the barrel nut glued into the cross brace.

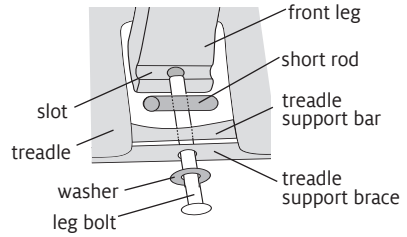

PLACING THE SHORT ROD

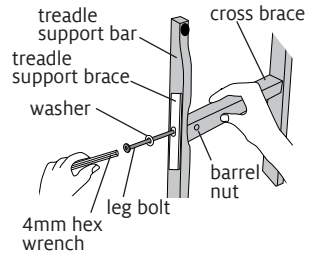

SECURING THE LEG BOLT

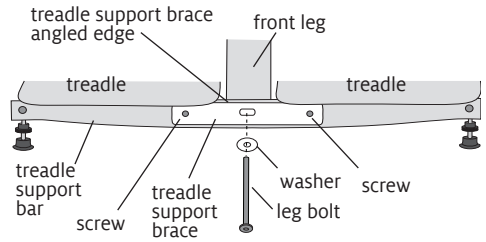

ATTACHING THE TREADLE

ATTACHING THE FOOTMAN

Attach the footman to the treadle using the cotter pin, clevis pin and the nylon washers that are packed in the small box with the flyer.

ADJUSTING THE TREADLE HEIGHT

This adjustment is only necessary if your treadle is either rubbing the drive wheel or hitting the rear leg cross support. To adjust the treadle height, remove the cotter pin from the treadle-yoke pin and pull the treadle-yoke pin out of the treadle yoke. Rotate the yoke clockwise to raise the treadle and counterclockwise to lower the treadle. Make only two or three turns and reassemble the footman and treadle yoke. Repeat this adjustment until you are satisfied with the position of the treadle.

ADJUSTING THE FRONT LEGS

The front legs of your spinning wheel can be adjusted to accommodate uneven floors. Simply loosen the lock nut and screw the foot up or down as needed, then tighten the lock nut.

INSTALLING THE FLYER ASSEMBLY

Pull the quick release lever (on the left side of the mother-of-all) toward you. Pivot the front maiden forward. Insert the flyer-bobbin-whorl assembly, fitting the small end of the flyer shaft into the rear maiden bearing. Be sure to lift the drive band up and over the bobbin and whorl pulleys. Pivot the front maiden up and fit the flyer orifice into the front maiden bearing. Push the quick release lever away from you to secure the flyer.

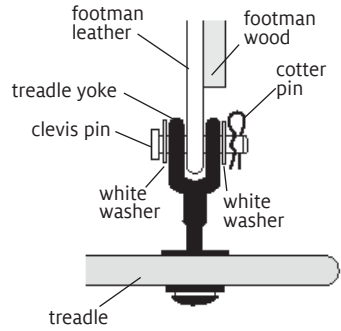

ATTACHING THE FOOTMAN

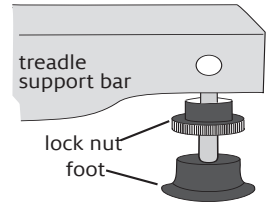

ADJUSTING THE FRONT LEGS

CHANGING BOBBINS

Open the quick release lever on the front maiden. Hold the flyer with one hand and pivot the front maiden forward until the flyer orifice is out of the front maiden bearing. Hold the drive band up and out of the way as you pull the flyer towards you until the flyer shaft is out of the rear maiden bearing. Remove the flyer whorl. (Unlike most spinning wheel flyer whorls that screw onto the flyer shaft, our quick-attach whorls push on and pull off the square part of the flyer shaft.) Remove the bobbin and replace it with another one. If you are spinning in double drive mode, face the small end of the bobbin toward the flyer whorl; in Scotch tension mode, the large end of the bobbin faces the flyer whorl.

DOUBLE DRIVE MODE

We have shipped your wheel set up for double drive mode, with a medium speed flyer whorl. (The fast speed whorl is attached to the wheel behind the rear maiden.) For double drive mode, the small end of the bobbin faces the flyer. Place one loop of the drive band over the small end on the bobbin and the other loop over one of the grooves (pulleys) of the flyer whorl.

Adjust the tension on the drive band by turning the drive band tension knob (the mushroom-shaped knob on top). Start with a loose drive band. Begin to slowly treadle, tightening the tension knob until the flyer and bobbin both begin to turn. Now you

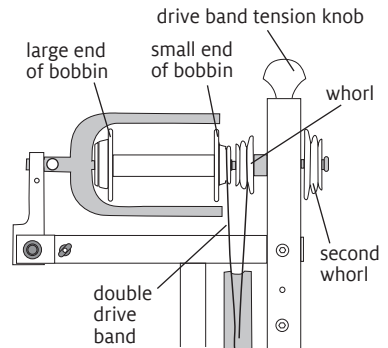

DOUBLE DRIVE MODE

can begin to spin. Turn the tension knob in a clockwise direction to increase the take-up of the yarn onto the bobbin or counter-clockwise to reduce the amount of take-up.

SCOTCH TENSION OR FLYER-LEAD MODE

Remove the flyer (see the “Changing Bobbins” section) and attach the Scotch tension brake spring and cord.

Slide the loop end of the Scotch tension brake spring and cord under the rear bar, laying the loop to one side. You can use your threading hook to pull the loop up if needed. Adjust the Scotch tension peg so that the hole in the shaft is visible. Take the straight end of the cord over the front bar and into the hole.

Install the flyer, with the large end of the bobbin toward the back of the wheel. Place the loop over the large end of the bobbin, and the drive band over the whorl. (You can use the drive band double for this, although we recommend tying a single drive band.) The drive band should be taut but not overly tight.

Turn the Scotch tension peg to take up the slack in the cord, allowing the cord to wind around the shaft of the peg. If the cord slips and won't wind up, you can make a double knot about 1" from the end of the knot. We don't recommend cutting the cord.

To increase the amount of take-up of your yarn onto the bobbin, adjust the Scotch tension peg. To decrease the amount of take-up, adjust the peg in the other direction.

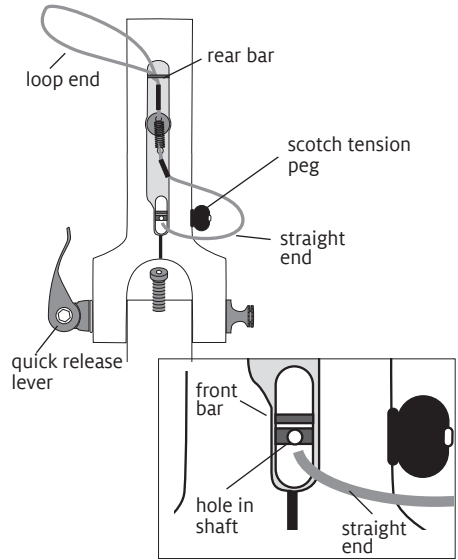

INSTALL THE SCOTCH TENSION BRAKE

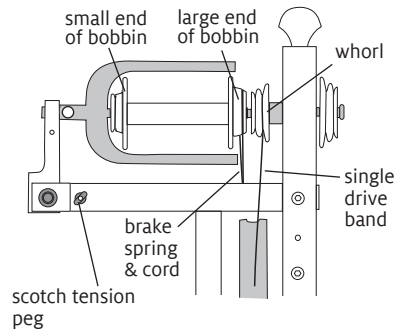

SCOTCH TENSION MODE

When using the Scotch tension mode the yarn will wind onto the bobbin in the opposite direction than when using the double drive mode. This does not affect your spinning, but it is good to know this in case you should change spinning modes in the middle of a bobbin.

YOUR DRIVE BAND

Your spinning wheel comes with a pre-tied drive band (tied for double drive) and an extra length of drive band. For additional drive bands, use a soft cotton cord which is about 1/16" thick (an eight or ten-ply butcher or package twine works fine). A soft drive band allows you to use less tension than a harder, slicker cord, making treading easier. While a soft drive band will wear quicker, we believe the gain in performance is worth changing the drive band more often.

TYING ON A NEW DRIVE BAND

Cut the old drive band to remove it.

For double drive mode, place a bobbin in the flyer with the small end facing the whorl. Use a medium size whorl. Adjust the drive band tension knob so that the flyer is parallel to the mother-of-all. Face the front of the wheel. Hang one end of the drive band cord over the bobbin groove so that it hangs down about 12 inches on the right side of the wheel. On the left side take the cord down and around the drive wheel and up and over the larger pulley of the whorl. Go down and around the drive wheel a second time. Bring the end of the cord up to

the first end. Tie the two ends together using a square knot. Make sure that the drive band very taut, since it will loosen some with use. Cut off the ends of the cord as close to the knot as possible.

For Scotch tension, use the same method above, except that only a single drive band is tied around the drive wheel and the whorl. If you are using the slow speed or extra slow speed whorls, it is best to tie a separate drive cord following the instructions above. Several drive cords can be left on the wheel at the same time. Just fold up the ones not in use and let them hang from the maiden or the front leg.

USING DIFFERENT FLYER WHORLS

The type of fiber you are spinning and the kind of yarn you want to produce will determine which flyer whorl to use. Your spinning wheel comes with

WHORL RATIOS

Whorl	Ratio
Extra Slow Speed	4:1 / 4.5:1
Slow Speed	6:1 / 7.5:1
Medium Speed (with wheel)	9:1 / 10.5:1
Fast Speed (with wheel)	12.6:1 / 15:1
*High Speed	17:1 / 20:1
*Super High Speed	18:1 / 21:1

*These whorls require the High Speed Bobbin.

two flyer whorls: a Medium Speed Whorl with 9:1 and 11:1 ratios and a Fast Speed Whorl with 13:1 and 15½:1 ratios. We offer four others (see the chart). The general rules to remember are: the larger (slower) the whorl, the thicker the yarn, the less the twist, and the greater the take-up. It is also important to remember that, in the double drive mode, depending on how much or how little tension you put on

the drive band, you can increase or decrease the take up. In the Scotch Tension mode the amount of take-up is controlled by the amount of tension you put on the brake spring & cord. The greater the tension, the greater the take-up.

THE WOOD IN YOUR SPINNING WHEEL

We use hard maple and black walnut in the finest grades available. All our wood is kiln dried to assure its stability under a variety of conditions. Maple is a strong and beautiful hardwood that varies in color from pale cream to biscuit brown. It has a very fine grain that takes a high polish and is extremely resistant to abrasion. American black walnut grows wild as a tall tree of the rich bottomland forests throughout the central eastern and mid-western United States. It is also successfully cultivated in other parts of the U.S. and Canada. Black Walnut's deep brown heartwood beautifully accents the design of your wheel.

Wood is a natural breathing material, and like any natural material, it is affected by its environment. Avoid placing your wheel near direct heat sources such as heat vents, wood stoves, space heaters, and direct sunlight. Heat concentrated on parts of the wheel can cause them to dry out and shrink. This shrinkage can cause weakness in the joints and the warping of parts. Likewise, place your wheel where it will be free of damp, moisture-laden air, as this can make wood swell and cause the moving

parts to stiffen and function inefficiently.

THE FINISH ON YOUR SPINNING WHEEL

The flyer of our spinning wheel has been lacquered to protect it from oil and moisture. The other parts of our wheel have been finished with Danish oil which penetrates into the wood, protecting the wood as well as the surface area. If you need to touch up parts of your wheel which have gotten chipped or scuffed, you can lightly sand the worn area and apply a small amount of finish using a soft lint-free rag. Use either Deft or Watco natural color Danish oil. Both are available at most hardware stores. Follow the directions on the container. Because of the dangers of spontaneous combustion, be sure to clean and dispose of the applicators and oily rags according to the manufacturer's instructions.

LUBRICATING THE MOVING PARTS

Before leaving the factory, your wheel was lubricated and tested. It may have been awhile since then, so it is a good idea to oil your wheel before starting to spin. Use a drop of oil on the following parts every couple of hours while spinning:

- front maiden bearing
- rear bearing
- bobbin bearings
- drive wheel bearings
- crank bearing(s) - sparingly

The flyer shaft should also be oiled where it touches the front and rear bearings and the bobbin bearings.

Use medium weight oil such as 20 or 30 weight motor oil. 🏠

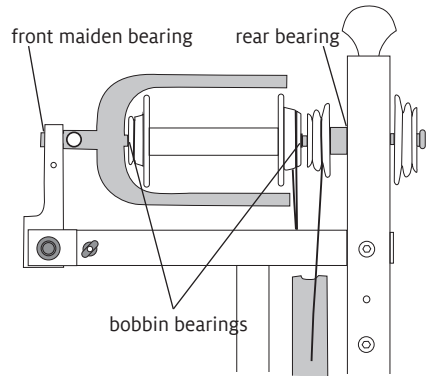

FLYER SHAFT OILING POINTS

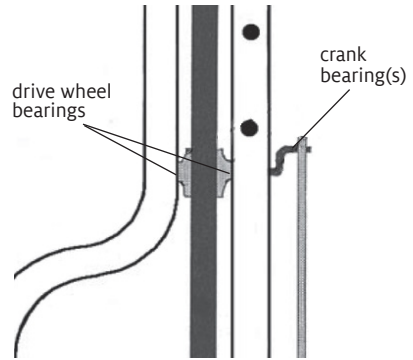

DRIVE WHEEL OILING POINTS

FOR FURTHER INFORMATION BOOKS

The Intentional Spinner by Judith MacKenzie

Spin Control: Techniques for Spinning the Yarn You Want by Amy King

Start Spinning by Maggie Casey

DVDs

The Gentle Art of Plying by Judith MacKenzie

Popular Wheel Mechanics by Judith MacKenzie

Start Spinning: The Video by Maggie Casey

Know Your Wheel by Alden Amos and Cindy Lair with Linda Ligon

THE INDUSTRIOUS LAZY KATE

Our Lazy Kate has an adjustable tension control cord which helps prevent bobbins from rotating too fast when releasing yarn. Our new design comes apart without tools so you can take your Kate with you.



BULKY PLYER FLYER HEAD

Add new capabilities to your Matchless Spinning Wheel with the Bulky Plyer Flyer Head. The generous 7/8" orifice allows you to spin yarns bigger than ever. The extra large capacity bobbin is great for extra long skeins. The package includes the Bulky Flyer and Front Maiden and one 8 ounce Bulky Bobbin.



SPINNING WHEEL CART

The neatest way ever to travel with your spinning wheel, the Schacht Spinning Wheel Cart is designed exclusively for the Schacht Spinning Wheel. The Cart comes with special hardware that replaces the bolts in the bottom of the spinning wheel rear legs. The rubber wheels give a smooth ride and they attach and detach quickly.



OIL BOTTLE

This is the perfect bottle for getting oil to all of those out of the way places on spinning wheels. It is useful for all kinds of household oiling jobs, too.



DIZZY YARN GAUGE

With both 1/2" and 1" measure, this gauge can be used as a spinner's yarn gauge, or a weaver's sett gauge. The hole in the center serves as a diz for making a consistent sliver for spinning.



MAINTENANCE NOTES

Your wheel is both a carefully engineered piece of equipment and a fine piece of furniture. A regular schedule of care and maintenance will ensure you and your Schacht Spinning Wheel many productive years together.

- Periodically clean excess fibers from all parts of your wheel.
- Periodically lubricate the moving parts.
- Touch up worn or chipped areas with fine sandpaper and Danish oil.
- Check screws for tightness.

(Changes in the environment and the action of spinning can cause screws and nuts to loosen over time.)

WHEEL SERIAL NUMBER

The serial # of your wheel is

_____.

The serial number of your spinning wheel is stamped into the wood on the rear of the mother-of-all. If the serial number on your wheel doesn't agree with the number written on this page, please reference the number stamped on your wheel.

TWO YEAR LIMITED WARRANTY

Your new Schacht Spinning Wheel is warranted, to the original consumer purchaser, by Schacht Spindle Company, Inc. to be free of defects in material and workmanship. Schacht Spindle Company's obligation under this Warranty shall be limited to the repair or replacement of any part or parts which may prove defective within two (2) years following the date of original purchase by the consumer, and which Schacht Spindle Company's examination shall disclose to our satisfaction to be thus defective.

If a problem with this Schacht Spindle Company product develops during the warranty period, first contact the Schacht Spindle Company dealer from whom you made the purchase. If the problem cannot be handled through your dealer, then contact our customer service department. At our option, it may be required that the product be returned to our factory freight prepaid for inspection and repair and/or replacement.

This Warranty covers normal consumer use and does not cover damage which occurs in shipment or damage which results from alteration, accident, misuse, abuse, or neglect.

This Warranty gives you specific legal rights, and you may also have other rights which vary from state to state.