

# LADYBUG LAZY KATE™

## ASSEMBLY

### USING THE KATE

1. If you have already installed retainer rings, remove them from the bobbin rods you wish to use for plying. If you want to make sure the yarn winds off in the same direction, either over the top or under the bottom, don't tension the bobbins. Secure each bobbin with a retainer ring.
2. If you wish to tension the bobbins, add them to the bobbin rods with the larger ends close to the wheel's front leg (Figure 6). Place a tension O-ring around the large groove (closest to the front leg) and stretch the O-ring around the nearest tension pulley. Repeat for all the bobbins you wish to tension, as shown in Figure 7. There are two pulleys on each side of the kate so that you can tension both bobbins on each side. Secure each bobbin with a retainer ring.

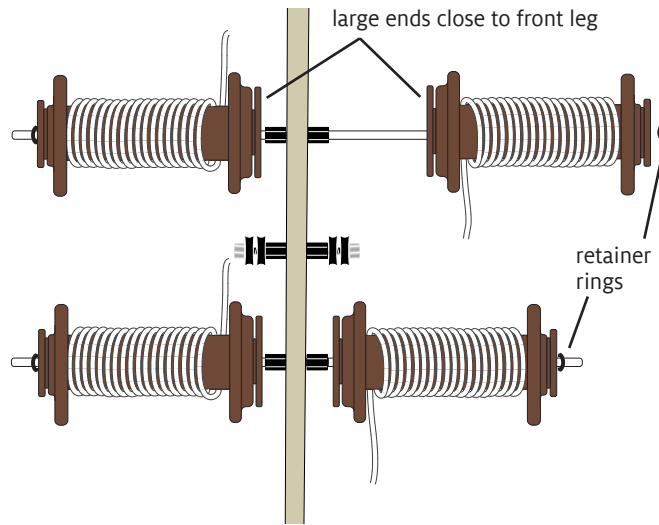

FIGURE 6: ADD BOBBINS

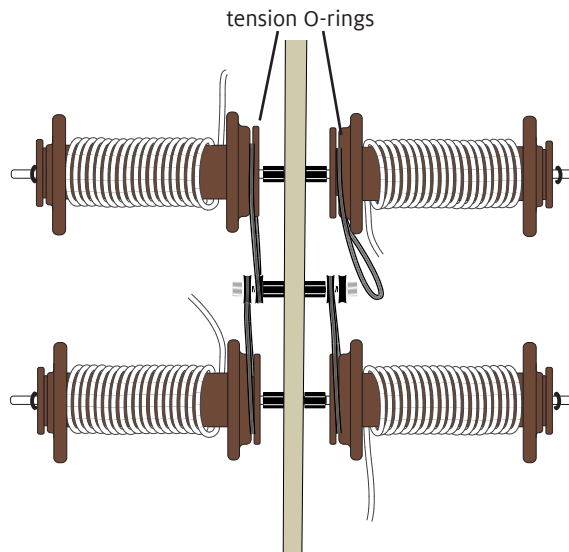
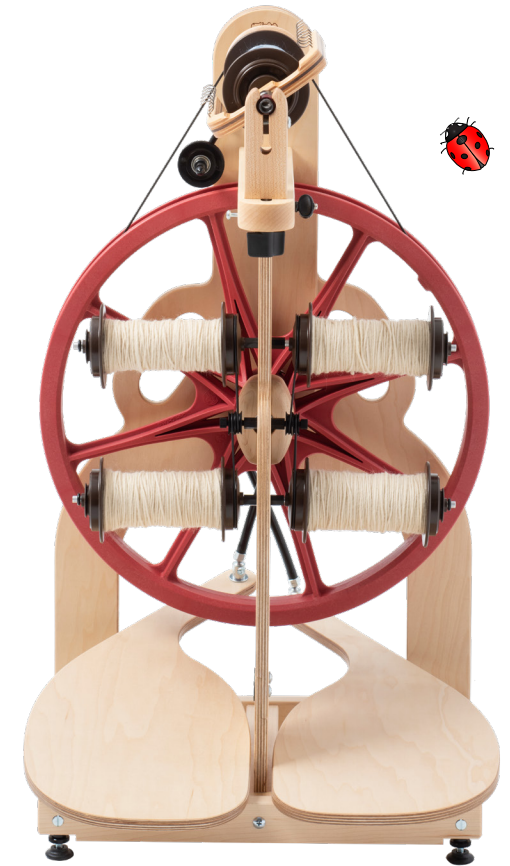

FIGURE 7: TENSION BOBBINS



Visit our website for more spinning accessories.



Find out more at [schachtspindle.com](http://schachtspindle.com)  
 Schacht Spindle Company  
 6101 Ben Place Boulder, CO 80301  
 p. 303.442.3212

# LADYBUG LAZY KATE™

## ASSEMBLY

### PARTS

- 3X coupler screws
- 6X coupler nuts
- 2X nylon socket head bolts
- 4X tension pulleys
- 4X bobbin rods
- 4X retainer rings
- 4X tension O-rings

### TOOLS REQUIRED

- 3/8" wrench & pliers
- or two 3/8" wrenches

Bobbins are not included.

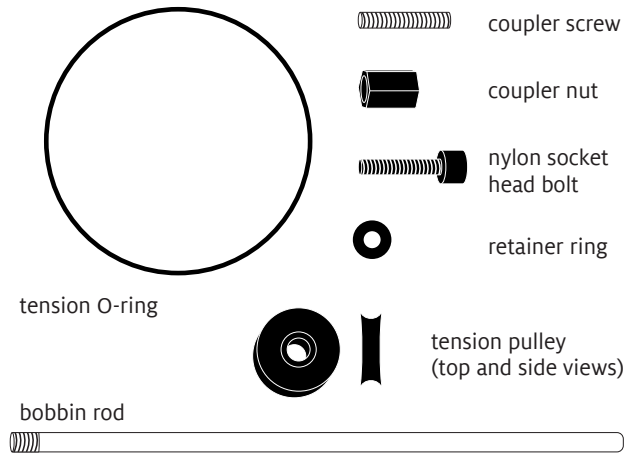

### ASSEMBLE THE KATE

Most illustrations here show only the wheel's front leg for clarity.

1. Insert coupler screws into the three holes in the front leg (Figure 1), centering the screws in the holes (Figure 2).
2. Hold one end of a coupler screw with your fingers to keep it from turning. Attach a coupler nut to the other end. Screw on the nut until it touches the front leg. Repeat with the remaining coupler nuts (Figure 3). Tighten all the coupler nuts with a wrench and pliers or two wrenches.
3. Insert a nylon socket head bolt through two of the tension pulleys. Attach the bolt to a coupler nut in the middle of the front leg (Figure 4). Repeat with the remaining nylon socket head bolts and tension pulleys, attaching them to the middle coupler nut on

the other side of the front leg.

4. Install a bobbin rod in each remaining coupler nut (Figure 5). If you wish, you can add bobbins and retainer rings now—the kate is a convenient place to store empty bobbins—or you can wait until you are ready to ply.

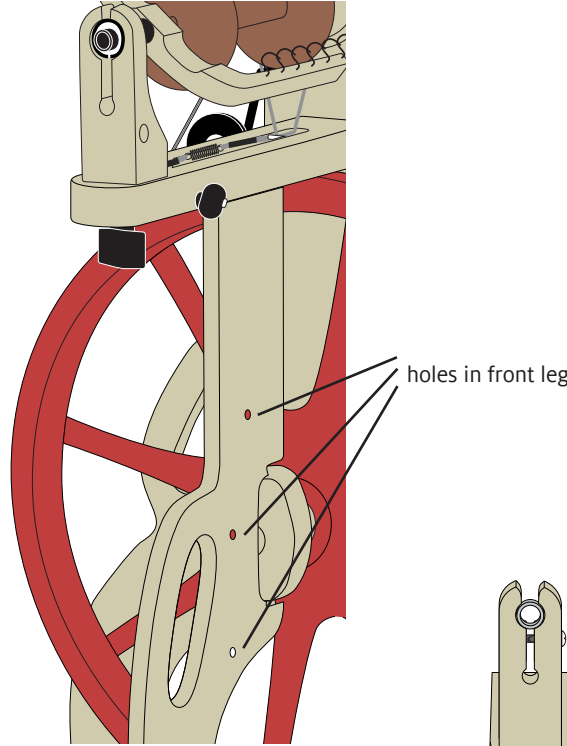

FIGURE 1: INSTALLING THE KATE

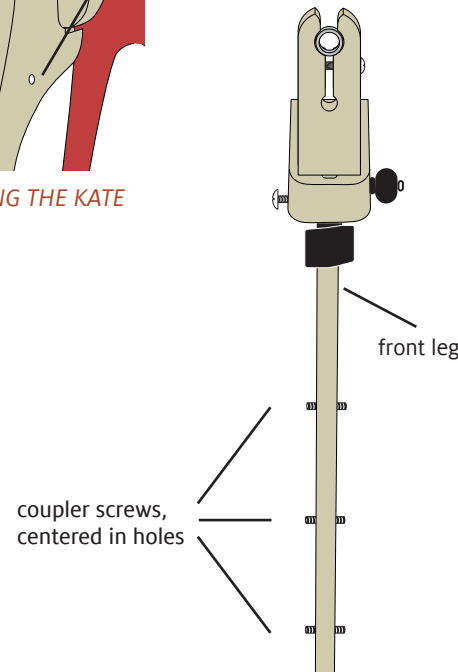

FIGURE 2: INSTALL COUPLER SCREWS

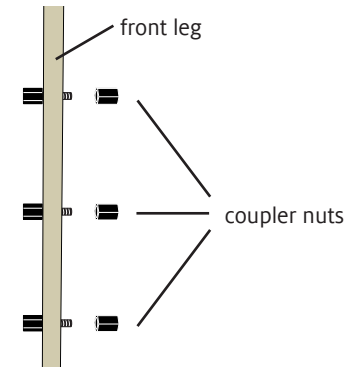

FIGURE 3: INSTALL COUPLER NUTS

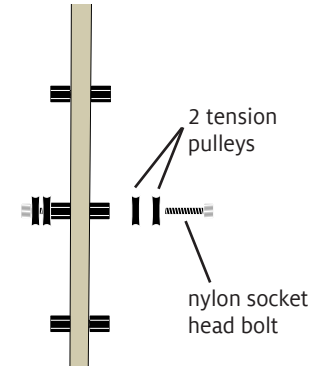

FIGURE 4: INSTALL TENSION PULLEYS

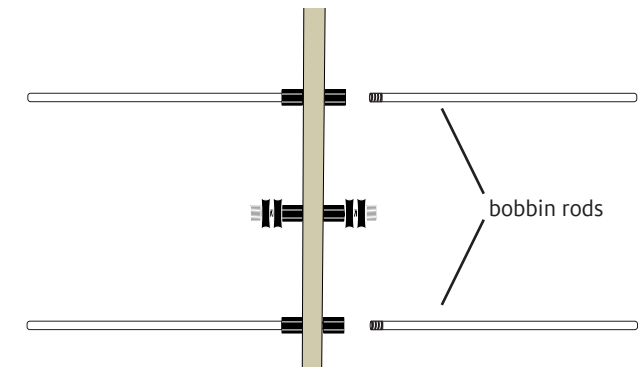

FIGURE 5: INSTALL BOBBIN RODS