

RF Power Reference Design Library

FM Broadcast Reference Design

High Ruggedness N-Channel Enhancement-Mode Lateral MOSFETs

Reference Design Characteristics

The MRFE6VP61K25H/HS are versatile devices and are well suited for a wide range of applications. They are capable of delivering 1.2 kW under continuous wave test signaling as a result of their high efficiency and low thermal resistance. This document focuses on FM broadcast radio applications for both analog and complex modulation waveforms.

- Frequency Band: 87.5–108 MHz
- Output Power: 1100 Watts CW
- Supply Voltage: 50 Vdc
- Power Gain (Typ): 25 dB
- Drain Efficiency (Min): 79% (at fundamental frequency)

The MRFE6VP61K25H/HS products are enhanced ruggedness 50 volt LDMOS power transistors that can operate in harsh environments and in highly mismatched applications (within the limit of maximum junction temperature). These parts are designed for high voltage operation and are fabricated using Freescale's very high voltage 6th generation (VHV6E) platform.

MRFE6VP61K25H
MRFE6VP61K25HS
FM Broadcast

87.5–108 MHz, 1100 W CW, 50 V
FM BROADCAST
REFERENCE DESIGN

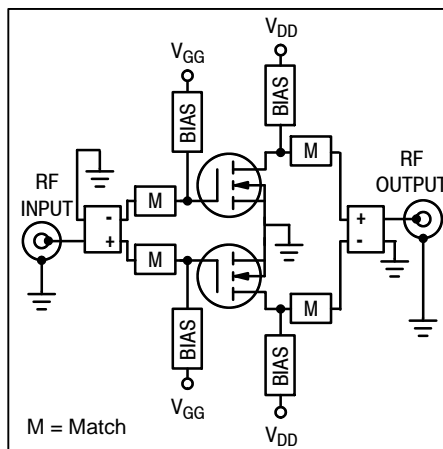

FM BROADCAST REFERENCE DESIGN

This reference design is designed to demonstrate the RF performance characteristics of the MRFE6VP61K25H/HS devices when applied to the 87.5–108 MHz FM broadcast frequency band. The reference design is tuned for performance at 1100 watts CW output power, $V_{DD} = 50$ volts and $I_{DQ} = 200$ mA.

own product or products. The reference design contains an easy-to-copy, fully functional amplifier design. It consists of “no tune” distributed element matching circuits designed to be as small as possible, and is designed to be used as a “building block” by our customers.

REFERENCE DESIGN LIBRARY TERMS AND CONDITIONS

Freescale is pleased to make this reference design available for your use in development and testing of your

HEATSINKING

When operating this fixture it is critical that adequate heat-sinking is provided for the device. Excessive heating of the device may prevent duplication of the included measurements and/or destruction of the device.

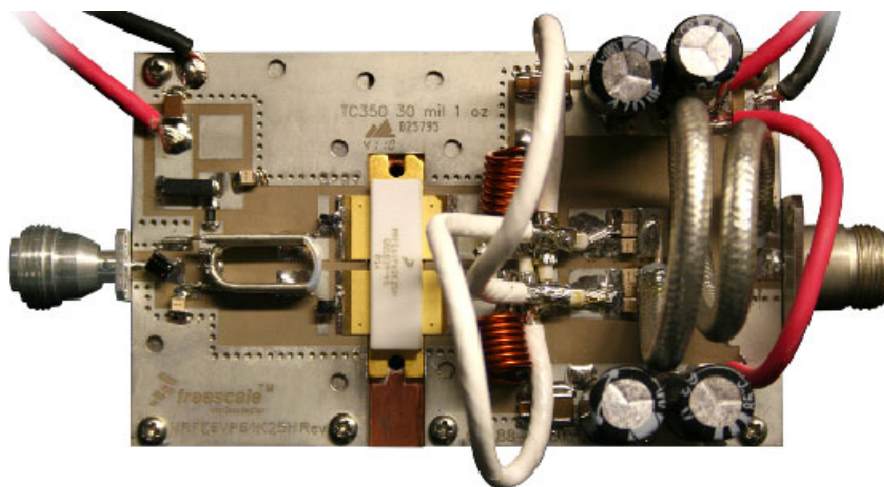

Figure 1. FM Broadcast Reference Design Fixture

MEASUREMENTS

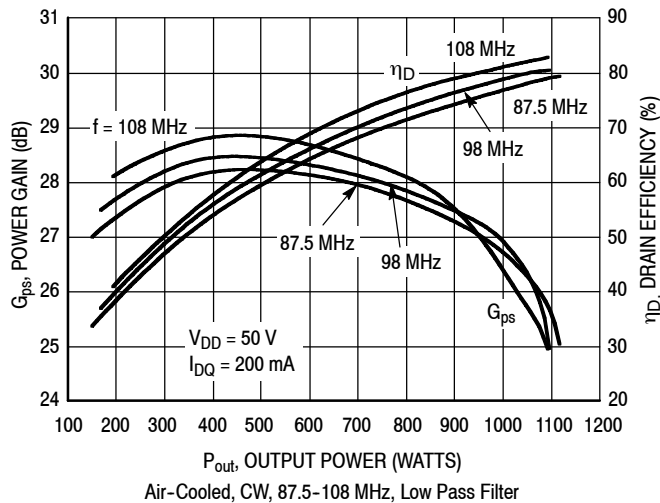

Figure 2. Continuous Wave Performance Graph with Low Pass Filter versus Output Power

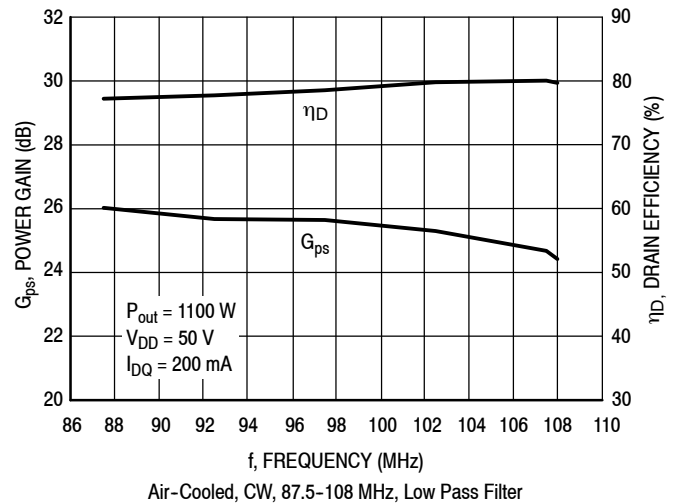

Figure 3. Continuous Wave Performance Graph with Low Pass Filter versus Frequency

Table 1. CW Drive-Up at 87.5 MHz

P_{in} (W)	P_{out} (W)	Gain (dB)	IRL (dB)	Eff (%)	V_{DD} (V)	I_{DD} (A)	$I_{DQ}^{(1)}$ (A)
0.3	150	27.0	-6.1	33.6	50	8.9	0.2
0.5	314	28.0	-6.5	48.0	50	13.1	0.2
1.0	639	28.1	-8.1	65.8	50	19.4	0.2
1.5	844	27.5	-10.1	72.6	50	23.2	0.2
2.0	975	26.9	-11.9	76.1	50	25.6	0.2
2.5	1056	26.3	-13.0	78.1	50	27.0	0.2
3.0	1100	25.6	-13.3	79.1	50	27.8	0.2
3.5	1116	25.0	-13.6	79.2	50	28.2	0.2

Table 2. CW Drive-Up at 98 MHz

P_{in} (W)	P_{out} (W)	Gain (dB)	IRL (dB)	Eff (%)	V_{DD} (V)	I_{DD} (A)	$I_{DQ}^{(1)}$ (A)
0.3	168	27.5	-11.0	36.8	50	9.1	0.2
0.5	343	28.4	-11.8	52.0	50	13.2	0.2
1.0	660	28.2	-14.9	68.5	50	19.3	0.2
1.5	864	27.6	-19.4	75.3	50	22.9	0.2
2.0	999	27.0	-22.4	78.7	50	25.4	0.2
2.5	1058	26.3	-22.0	80.1	50	26.4	0.2
3.0	1085	25.6	-22.0	80.2	50	27.0	0.2
3.5	1094	24.9	-22.6	80.4	50	27.2	0.2

Table 3. CW Drive-Up at 108 MHz

P_{in} (W)	P_{out} (W)	Gain (dB)	IRL (dB)	Eff (%)	V_{DD} (V)	I_{DD} (A)	$I_{DQ}^{(1)}$ (A)
0.3	193	28.1	-14.2	40.9	50	9.4	0.2
0.5	377	28.8	-14.9	56.1	50	13.4	0.2
1.0	695	28.4	-15.6	72.9	50	19.1	0.2
1.5	881	27.7	-13.5	78.6	50	22.4	0.2
2.0	980	26.7	-14.1	79.2	50	22.9	0.2
2.5	1018	26.1	-12.2	81.6	50	24.9	0.2
3.0	1066	25.5	-11.8	82.4	50	25.9	0.2
3.5	1092	24.9	-11.8	82.7	50	26.4	0.2

1. I_{DQ} is set by adjusting a variable gate-source voltage while maintaining a constant 50 volts at the drain.

MATCHING NETWORK

As a first order approximation, the typical maximum efficiency impedance point corresponds to a 25% power degradation from the maximum P3dB impedance. The maximum output power impedance value on this device corresponds to a 1.25 kW output capability from 87.5-108 MHz. This puts the targeted P1dB compression value at 800 watts of output power total, or 400 watts per side. The initial load impedance is determined using the following equation:

$$R = \frac{(0.85 \times V_{DD})^2}{(2 \times P_{out})} = \frac{(0.85 \times 50 V)^2}{(2 \times 400 W)} = 2.25 \Omega$$

$$R \text{ (drain to drain)} = 2.25 \Omega \times 2 = 4.5 \Omega$$

The coaxial transformer turns ratio was chosen to meet this required impedance level and the length of the coax (series inductance) was tuned to attain maximum efficiency and maximum power transfer between the device and its complex conjugate test fixture load impedance.

FIXTURE IMPEDANCE

$V_{DD} = 50 \text{ Vdc}$, $I_{DQ} = 200 \text{ mA}$, $P_{out} = 1100 \text{ W CW}$

f MHz	Z _{source} Ω	Z _{load} Ω
87.5	2.20 + j6.70	4.90 + j2.90
98	2.30 + j6.90	4.10 + j2.50
108	2.30 + j7.00	4.40 + j3.60

Z_{source} = Test circuit impedance as measured from gate to gate, balanced configuration.

Z_{load} = Test circuit impedance as measured from drain to drain, balanced configuration.

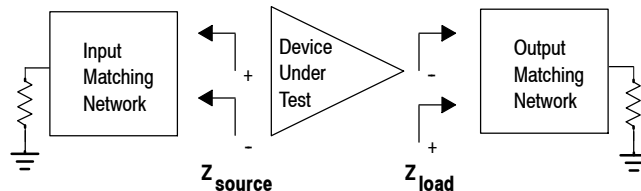

Figure 4. Series Equivalent Source and Load Impedance

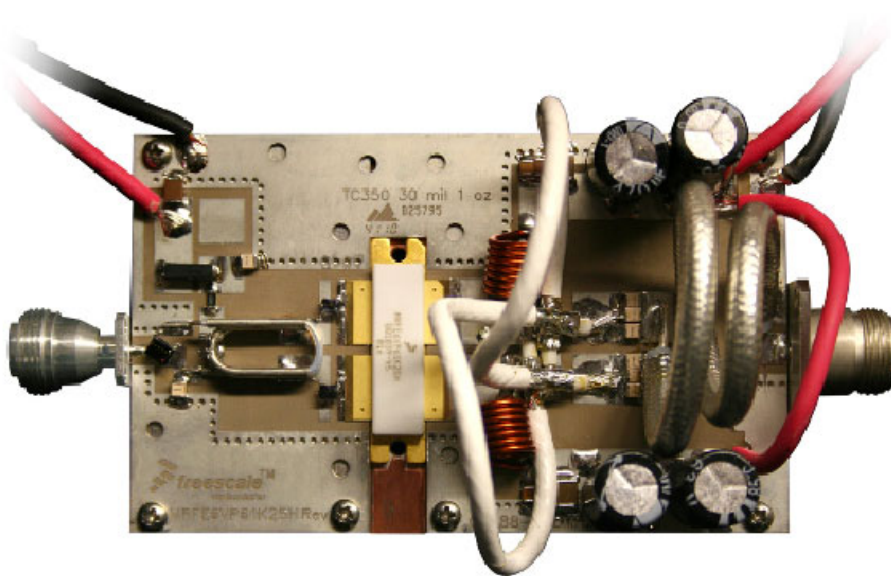

Figure 5. FM Broadcast Reference Design Fixture Impedance

CIRCUIT DESCRIPTION

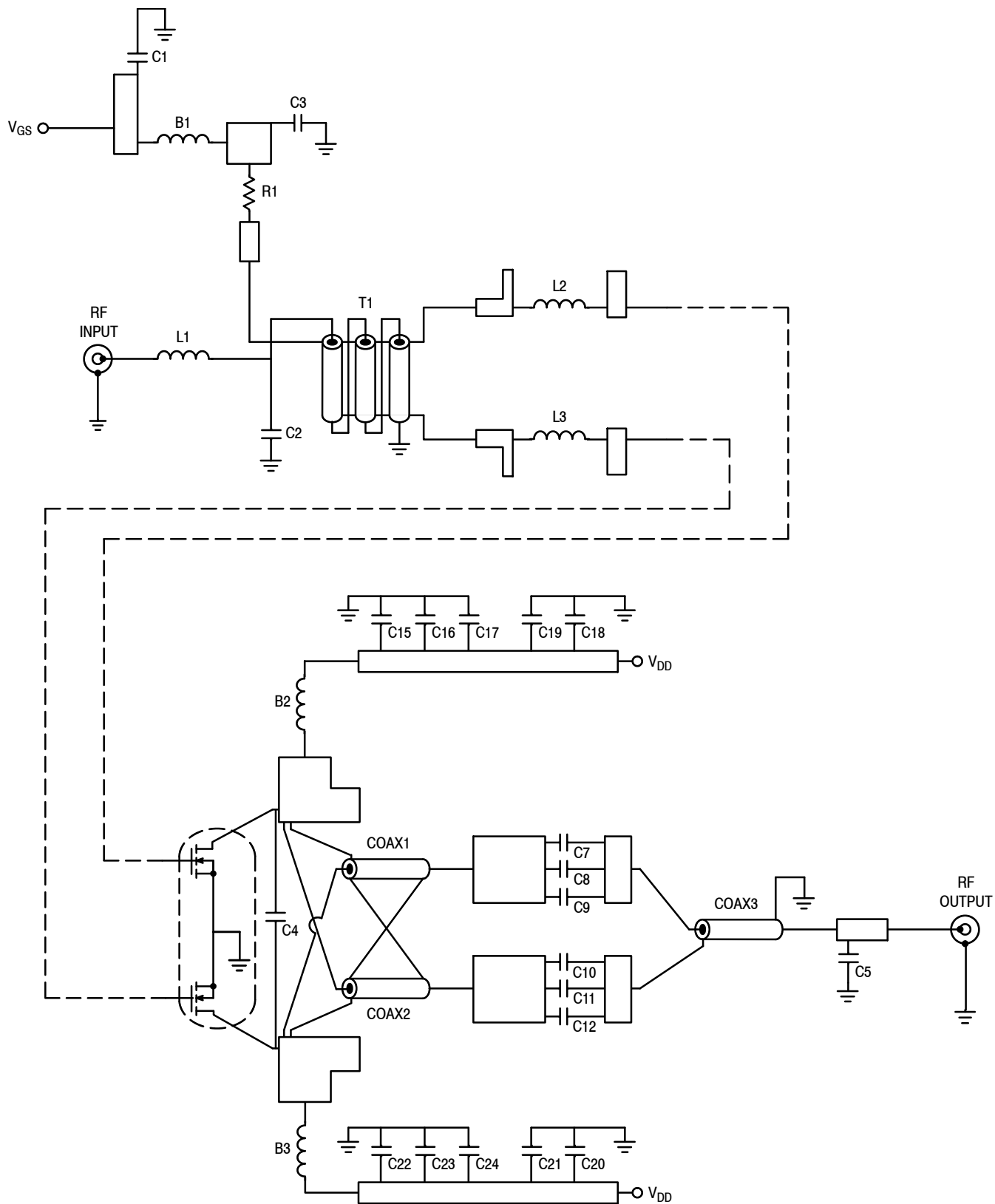

Figure 6. FM Broadcast Reference Design Schematic Diagram

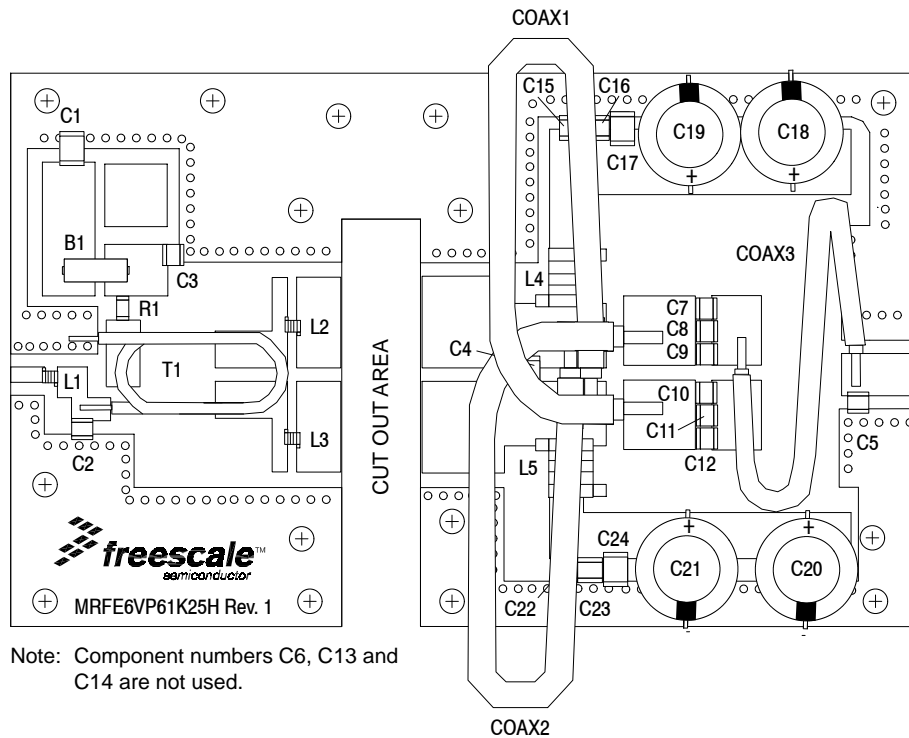

Figure 7. FM Broadcast Reference Design Component Layout

Table 4. FM Broadcast Reference Design Component Designations and Values

Part	Description	Part Number	Manufacturer
B1	Long Ferrite Bead	2743021447	Fair-Rite
C1	6.8 μ F, 50 V Chip Capacitor	C4532X7R1H685K	TDK
C2	27 pF Chip Capacitor	ATC100B270JT500XT	ATC
C3, C7, C8, C9, C10, C11, C12	1000 pF Chip Capacitors	ATC100B102JT50XT	ATC
C4	39 pF Mica Capacitor	MIN02-002DC390J-F	Cornell Dubilier
C5	3 pF Chip Capacitor	ATC100B3R0CT500XT	ATC
C15, C22	10K pF Chip Capacitors	ATC200B103KT500XT	ATC
C16, C23	1 μ F, 100 V Chip Capacitors	C3225JB2A105KT	TDK
C17, C24	10 μ F, 100 V Chip Capacitors	C5750X7S2A106MT	TDK
C18, C19, C20, C21	470 μ F, 63 V Electrolytic Capacitors	477KXM063M	Illinois Capacitor
L1	39 nH Inductor	1812SMS-39NJLC	Coilcraft
L2, L3	2.5 nH Inductors	A01TKLC	Coilcraft
L4, L5	7 Turn, #16 AWG, ID = 0.3" Inductors	Copper Wire	
R1	11 Ω , 1/4 W Chip Resistor	CRCW120611R0FKEA	Vishay
T1	Balun	TUI-9	Comm Concepts
Coax1, Coax2	Flex Cables, 12 Ω , 5.9"	TC-12	Comm Concepts
Coax3	Coax Cable, Quickform 50 Ω , 8.7"	SUCOFORM 250-01	Huber+Suhner
PCB*	0.030", $\epsilon_r = 3.5$	TC-350	Arlon
Heatsink	NI-1230 Copper Heatsink	C193X280T970	Machine Shop

*PCB artwork for this reference design is available at <http://freescale.com/RFbroadcast> > Design Support > Reference Designs.

Note: See Appendix A for Tuning Tips.

50 V Drain Voltage

The 87.5–108 MHz FM broadcast reference design fixture was designed to utilize the standard 50 volt power supply commonly used in this market.

Data was collected to characterize the reference design's output power and efficiency vs. drain voltage, as shown in Figure 8. The output power can be adjusted over a 12 dB worth of dynamic range by adjusting the drain voltage, while creating minimal degradation on the efficiency performance.

Refer to Freescale's *50 V RF LDMOS White Paper*. Go to <http://freescale.com/RFpower> and select Documentation/White Papers - 50VRF LDMOSWP for more information on 50 V RF LDMOS technology.

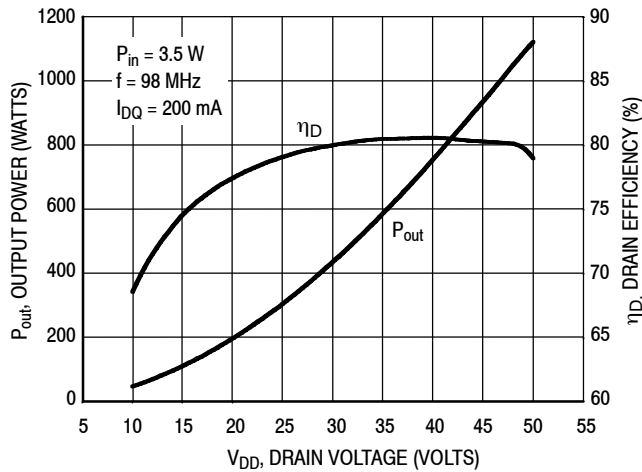

Figure 8. Output Power and Drain Efficiency versus Drain Voltage

Extended Gate Voltage Range

The enhanced electrostatic discharge (ESD) protection structure at the gate of the transistor is a Freescale innovation pioneered in the cellular infrastructure market that is incorporated into the 50 volts RF LDMOS power product portfolios. This ESD structure can tolerate moderate reverse bias conditions, applied to the gate lead, up to -6 volts as shown in Figure 9. This allows these transistors to be used in zero gate voltage, Class C bias applications where the RF voltage swings on the gate can be significantly lower than the ground potential.

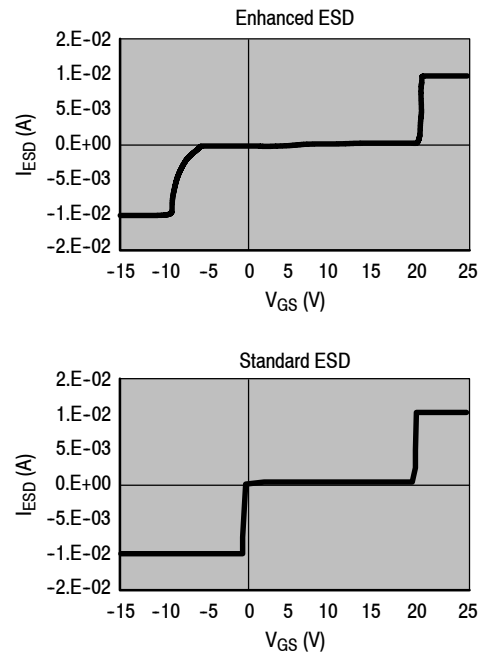

Figure 9. Gate Voltage Breakdown with ESD

High Ruggedness/Energy Absorption

The MRFE6VP61K25H/HS was designed to operate in applications which demand very high ruggedness. The VHV6E technology has proven to be valuable in FM broadcast applications, specifically in high definition (HD) FM transmitters where a high peak-to-average (PAR) digital signal is injected on top of an existing analog FM signal. At the peak of the signal, the voltage waveform could exceed the V_{(BR)DSS} breakdown voltage of the device and thus cause the device to enter into an avalanche condition. However, for the device to fail, the current must be sufficiently high enough during the high voltage period to activate the internal parasitic bipolar transistor buried beneath the active field-effect transistor (FET) structure.

An Integrated Technologies Corporation's Unclamped Inductive Load Tester, model #ITC55100B, was used to measure the maximum energy dissipation capability of the device under these high current and high voltage test conditions.

Figure 10 shows the internal diagram of the ITC55100B tester. The tester controller activates the pulse generator to turn on the device under test (DUT) through the limiting and terminating resistor, R_G , creating a very clean gate pulse waveform. This pulse waveform tests the maximum energy dissipation capability of the DUT by stressing it under various, controlled energy levels. This is accomplished by attaching an unclamped inductive load to the device's drain and source connection and then increasing both the load current and load voltage up until the point that the DUT

failure is achieved. Using this test method for power devices ensures proper operation in circuits used to drive inductive loads that may possibly cause an avalanche mode stress on the DUT. The final maximum energy dissipation capability rating, in joules, is calculated by the following equation:

$$E = \frac{1}{2} \times L \times I^2$$

where L is the load inductance value and I is the peak current within the load inductor.

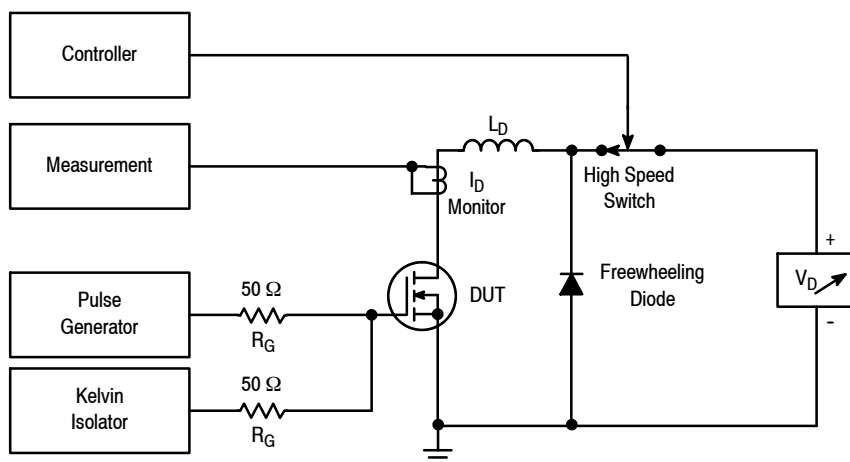

Figure 10. Internal Diagram of the ITC55100B Tester

The highest energy level the MRFE6VP61K25H/HS device passed is shown in Figure 11. During the course of this testing, the device dissipated over 5.77 joules of energy over a discharge time of 859 μ sec, while reaching a

maximum current of 76 A and a maximum voltage of 197 volts. (These load voltage and current values are taken under short discharge durations to keep the thermal dissipation issues out of the ruggedness equation.)

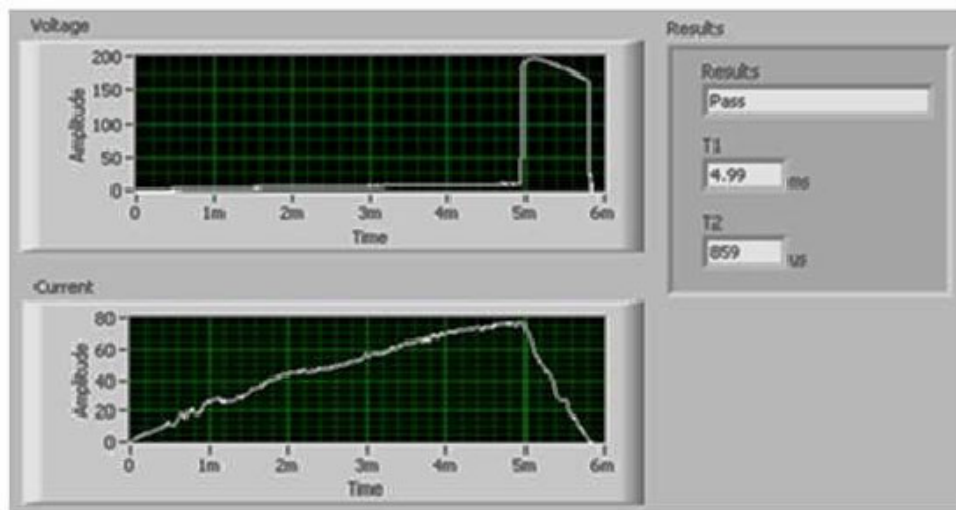

Figure 11. Voltage and Current Curves During Energy Discharge

- Max Voltage = 196.8 Vdc
- End Voltage = 167.5 Vdc
- Energy = 5.766 J (full device)
- $I_{D_{peak}} = 76$ A

Reliability

Mean time to failure (MTTF) is defined as a 10% reduction in current handling capability on 50% of the devices within a given sample size. The primary factor in device failure is due to metal electromigration on the die surface. Once the average operating conditions for a given application are determined, then the MTTF can be calculated using the thermal resistance R_{th} value given in the MRFE6VP61K25H product data sheet.

Example: If the desired operating output power is 1100 watts, with 80% drain efficiency:

- $I_{Drain} = 1100 \text{ W} / (80\% \times 50 \text{ V}) \sim 27.5 \text{ A}$
- MRFE6VP61K25H $R_{th} = 0.15^\circ\text{C}/\text{W}$, case temperature = 80°C
- Dissipated power = $P_{dc} - P_{out} + P_{in}$
- Dissipated power = $50 \text{ V} \times 27.5 \text{ A} - 1100 \text{ W} + 4 \text{ W} = 279 \text{ W}$
- Temperature rise = $279 \text{ W} \times 0.15^\circ\text{C}/\text{W} = 42^\circ\text{C}$
- $T_J = T_{rise} + T_C = 42^\circ\text{C} + 80^\circ\text{C} = 122^\circ\text{C}$

Utilizing Figure 12 which calculates MTTF versus I_{Drain} and T_J ; $I_{Drain} = 27.5 \text{ A}$, MTTF for this example is 2700 years.

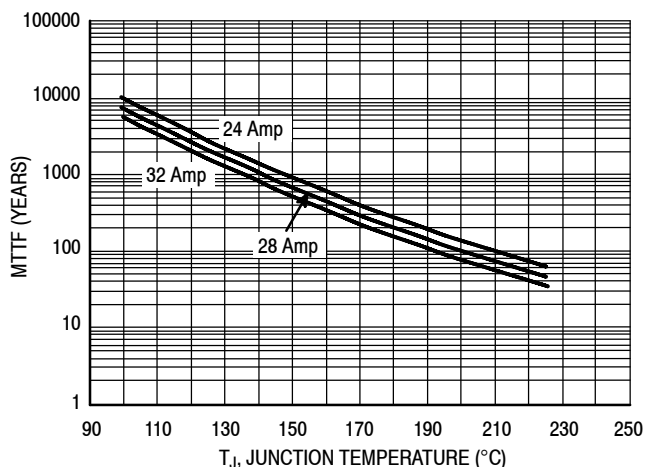
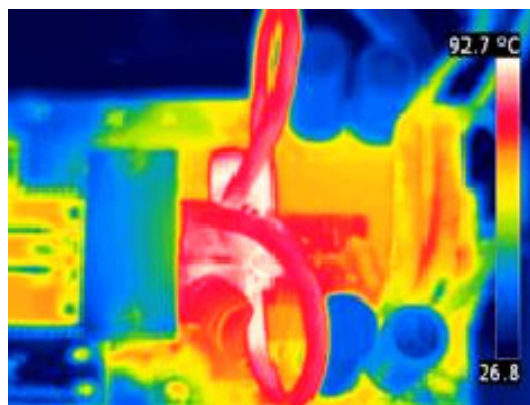

Figure 12. MTTF versus Junction Temperature

THERMAL MEASUREMENTS

Thermal images of the MRFE6VP61K25H FM broadcast reference circuit were taken using a FLIR Infrared(IR) T360 camera. The hottest point observed was located at the Coax1 and Coax2 junction point with the C4 mica capacitor at 108 MHz. The recorded temperature was 100°C after 10 minutes of operation to reach steady state temperature. Due to the high efficiency achieved by the FM broadcast reference fixture, the overall baseplate temperature remains relatively cool at around 60°C , with forced air cooling at 25°C .



87.5 MHz, 1100 W CW, 79% Drain Efficiency

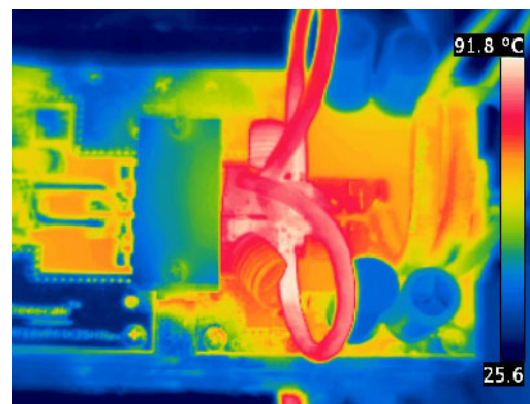

98 MHz, 1100 W CW, 78% Drain Efficiency

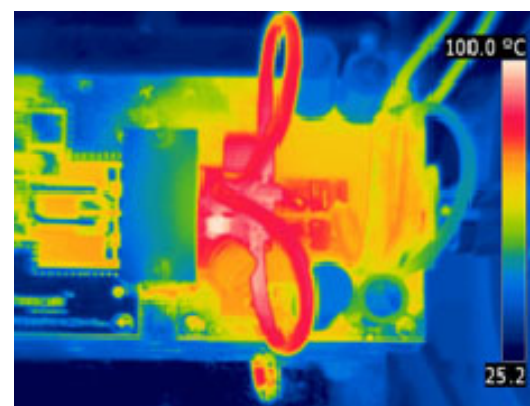

108 MHz, 1100 W CW, 80% Drain Efficiency

Figure 13. IR Images of the Output Matching Network

APPENDIX A

Tuning Tips

- Increasing C4 increases efficiency at the low end of the band (87.5 MHz), but there is a trade-off in power at the high end of the band.
- Increasing the length of Coax3 increases efficiency at the low end of the band (87.5 MHz), but there is a trade off in efficiency and power at the high end of the band.
- Make sure all the coax are measured tip to tip.
- Increasing C5 increases the power, but lowers efficiency.
- Moving C4 closer to the device will improve efficiency across the band, and lowers peak power at the high end of the band.

APPENDIX B

Mounting Tips

The MRFE6VP61K25H/HS is packaged in the industry standard NI-1230 air cavity package which offers outstanding thermal performance.

This package can be assembled into a power amplifier system using several different mounting methods. The popular options include bolting down with screws, clamping and reflow soldering. Freescale recommends the solder reflow method for best thermal and electrical performance.

One of the key advantages to solder mounting includes a superior source contact-to-heatsink interface that provides for lower thermal resistance as well as better electrical grounding, which means that high power RF devices such as the MRFE6VP61K25H/HS parts will have a lower junction temperature and better RF performance when compared to all other mounting options. Lowering the junction temperature of the device also increase the MTTF (Mean Time to Failure), as shown in Figure 8, MTTF versus Junction Temperature.

Refer to AN1908 *Solder Reflow Attach Method for High Power RF Devices in Air Cavity Packages*. Go to <http://freescale.com/RFpower> and select Documentation/ Application Notes - AN1908 for more information on solder reflow attach method.

APPENDIX C

RF Bench Setup/Continuous Wave Performance (CW)

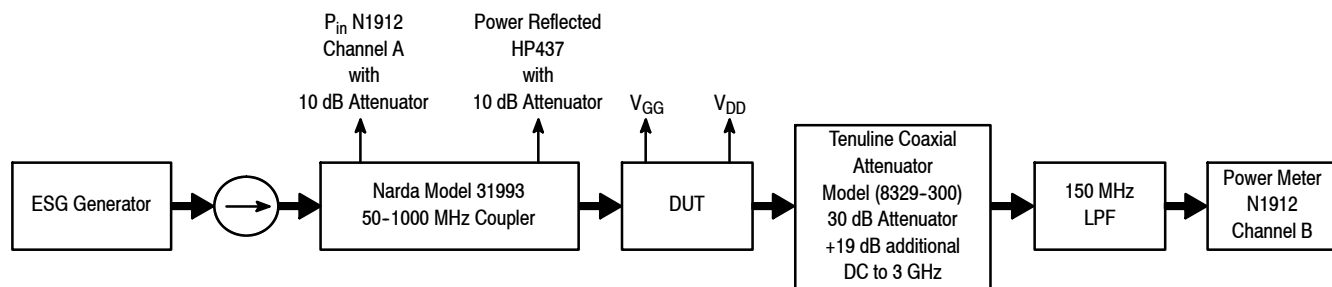
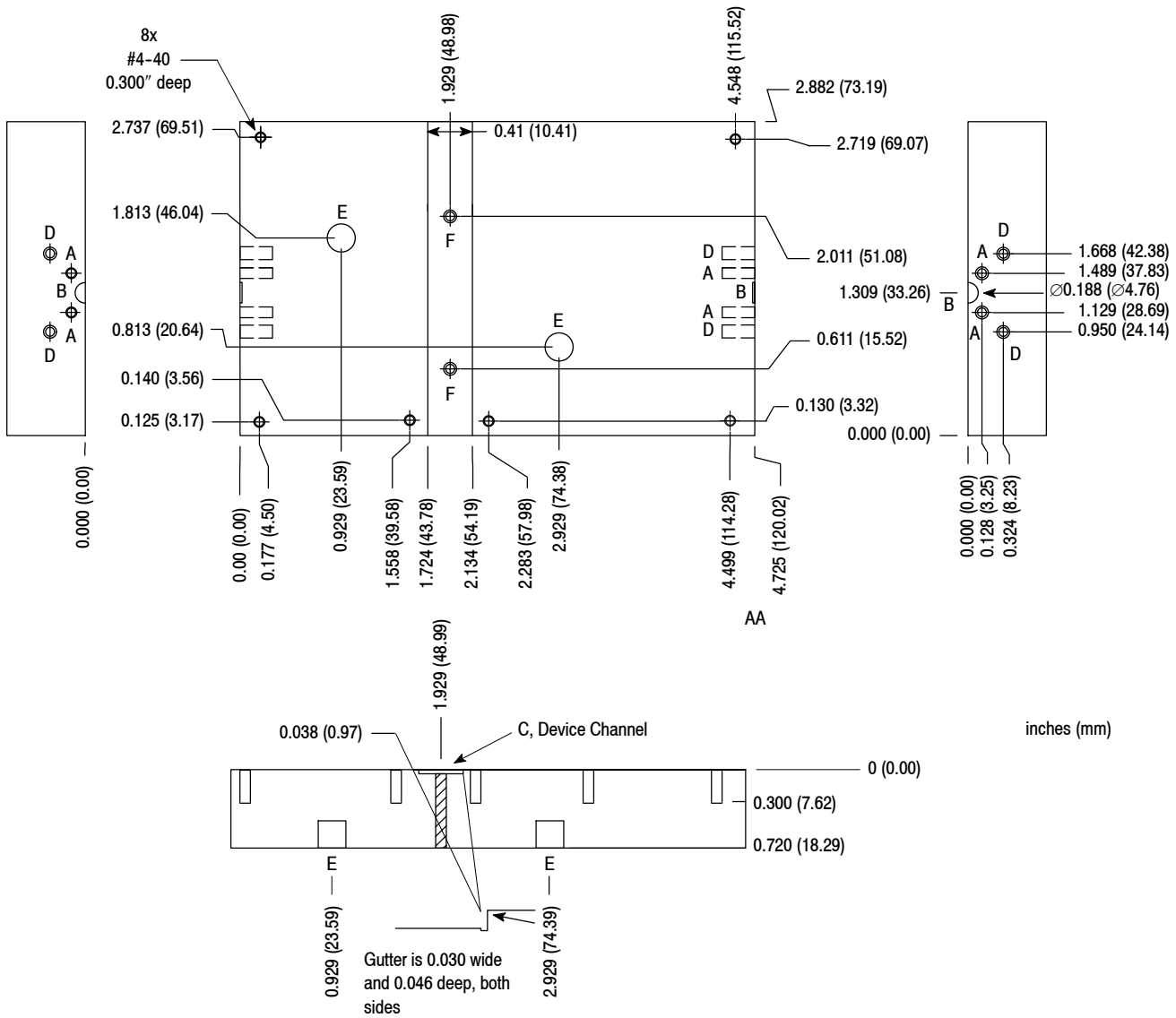

Figure 14. RF Bench Setup

Copper Heatsink for FM Broadcast Fixture



0.720" Copper Heatsink Hole Details

Designators	Details
A	2 places, both sides, drill and tap, #2-56 screw depth 0.300"
B	2 places, both sides, 0.1875" diameter notch 0.020" deep
C	NI-1230 channel 0.410" wide by 0.0380" deep
D	2 places, both sides, drill depth 0.250" and tap for #4-40 screw
E	Locator holes from bottom diameter = 0.257", depth = 0.400"
F	2 places, drill through and tap for #4-40 screw

Figure 15. NI-1230 Heatsink

REVISION HISTORY

The following table summarizes revisions to this document.

Revision	Date	Description
1	May 2011	<ul style="list-style-type: none"> • Table 4, Component Designations and Values, updated C17, C24 capacitor from “50 V, GRM55DR61H106KA88L, Murata” to “100 V, C5750X7S2A106MT, TDK”, 100 V part provides higher breakdown voltage capability. Corrected R1 part number from “CRCW1206110FKEA” to CRCW120611R0FKEA”. For Coax1, 2, 3, in description changed cm to inches, p. 4.
1.1	June 2011	<ul style="list-style-type: none"> • Content flow of the reference design document was restructured • Appendix A, Tuning Tips, added additional information, p. 9

How to Reach Us:

Home Page:

www.freescale.com

Web Support:

<http://www.freescale.com/support>

USA/Europe or Locations Not Listed:

Freescale Semiconductor, Inc.
Technical Information Center, EL516
2100 East Elliot Road
Tempe, Arizona 85284
1-800-521-6274 or +1-480-768-2130
www.freescale.com/support

Europe, Middle East, and Africa:

Freescale Halbleiter Deutschland GmbH
Technical Information Center
Schatzbogen 7
81829 Muenchen, Germany
+44 1296 380 456 (English)
+46 8 52200080 (English)
+49 89 92103 559 (German)
+33 1 69 35 48 48 (French)
www.freescale.com/support

Japan:

Freescale Semiconductor Japan Ltd.
Headquarters
ARCO Tower 15F
1-8-1, Shimo-Meguro, Meguro-ku,
Tokyo 153-0064
Japan
0120 191014 or +81 3 5437 9125
support.japan@freescale.com

Asia/Pacific:

Freescale Semiconductor China Ltd.
Exchange Building 23F
No. 118 Jianguo Road
Chaoyang District
Beijing 100022
China
+86 10 5879 8000
support.asia@freescale.com

For Literature Requests Only:

Freescale Semiconductor Literature Distribution Center
1-800-441-2447 or +1-303-675-2140
Fax: +1-303-675-2150
LDCForFreescaleSemiconductor@hibbertgroup.com

Information in this document is provided solely to enable system and software implementers to use Freescale Semiconductor products. There are no express or implied copyright licenses granted hereunder to design or fabricate any integrated circuits or integrated circuits based on the information in this document.

Freescale Semiconductor reserves the right to make changes without further notice to any products herein. Freescale Semiconductor makes no warranty, representation or guarantee regarding the suitability of its products for any particular purpose, nor does Freescale Semiconductor assume any liability arising out of the application or use of any product or circuit, and specifically disclaims any and all liability, including without limitation consequential or incidental damages. "Typical" parameters that may be provided in Freescale Semiconductor data sheets and/or specifications can and do vary in different applications and actual performance may vary over time. All operating parameters, including "Typicals", must be validated for each customer application by customer's technical experts. Freescale Semiconductor does not convey any license under its patent rights nor the rights of others. Freescale Semiconductor products are not designed, intended, or authorized for use as components in systems intended for surgical implant into the body, or other applications intended to support or sustain life, or for any other application in which the failure of the Freescale Semiconductor product could create a situation where personal injury or death may occur. Should Buyer purchase or use Freescale Semiconductor products for any such unintended or unauthorized application, Buyer shall indemnify and hold Freescale Semiconductor and its officers, employees, subsidiaries, affiliates, and distributors harmless against all claims, costs, damages, and expenses, and reasonable attorney fees arising out of, directly or indirectly, any claim of personal injury or death associated with such unintended or unauthorized use, even if such claim alleges that Freescale Semiconductor was negligent regarding the design or manufacture of the part.

Freescale™ and the Freescale logo are trademarks of Freescale Semiconductor, Inc. All other product or service names are the property of their respective owners.

© Freescale Semiconductor, Inc. 2011. All rights reserved.