

RAPID RAIL LINE RAIL KIT

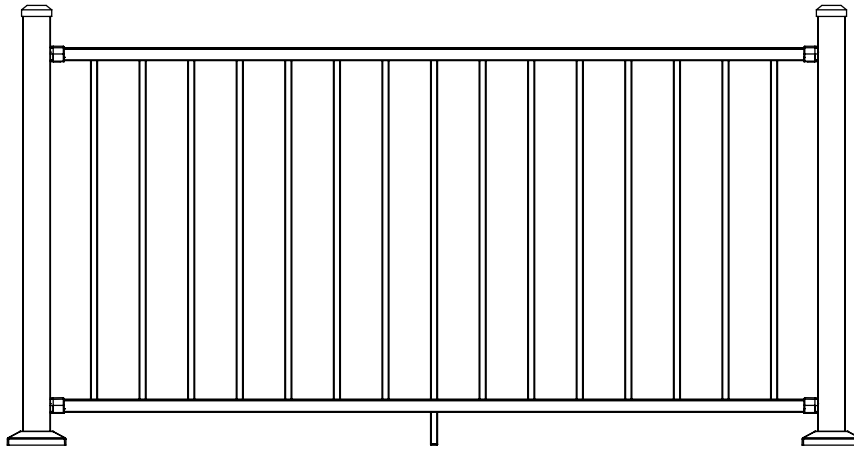

Scan here for additional information and installation videos



Top Rail Profile

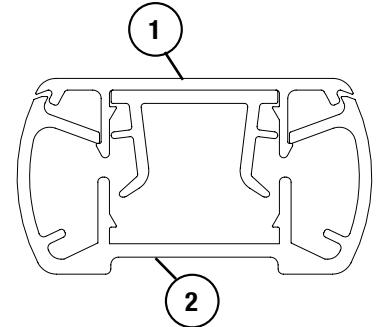

Bottom Rail Profile

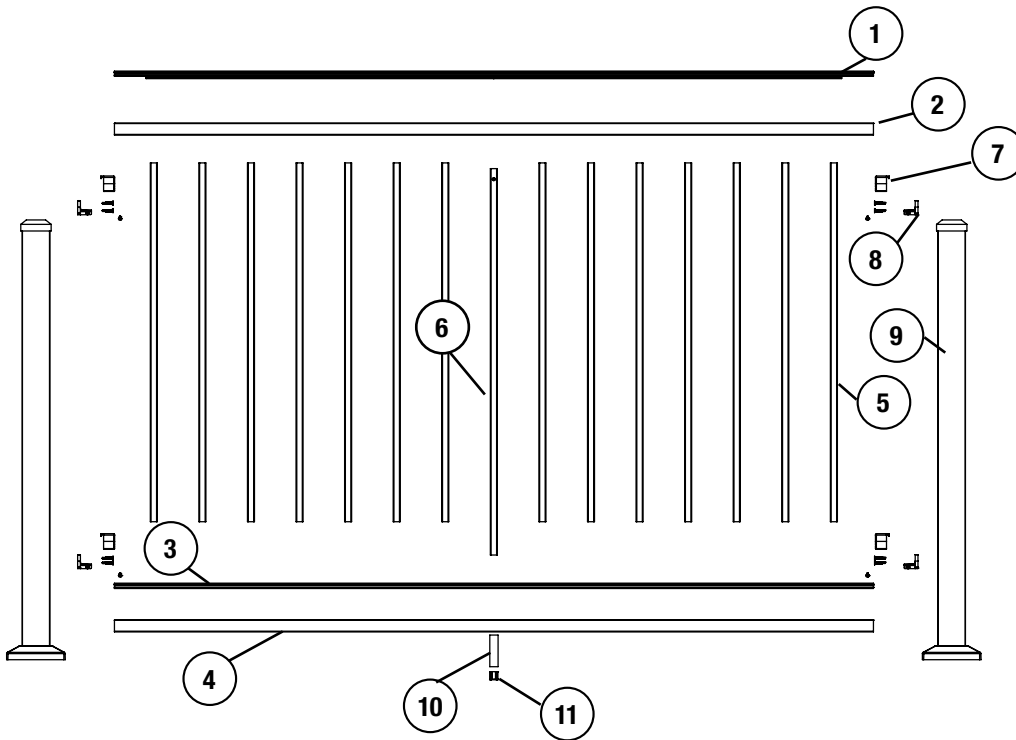
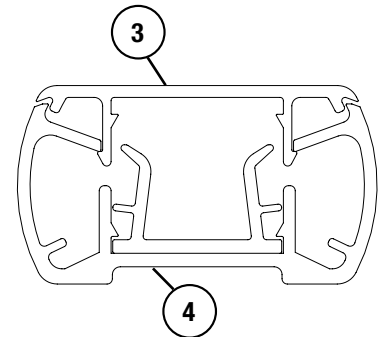

Component List

1. Top Rail Cap
 2. Top Rail Base
 3. Bottom Rail Cap
 4. Bottom Rail Base
 5. 5/8" Square Baluster
 6. 5/8" Support Baluster
 7. Bracket Cap
 8. Bracket Base
 9. Post Assembly
(Sold Separately)
 10. Crush Sleeve
 11. Crush Sleeve Cap
- *All hardware included
(10) 1/2" #8 Screws
(10) 1" #10 Screws

Prior to construction:

Check with your local regulatory agency for special code requirements in your area. Common railing height is 36" or 42". Read instructions completely to get an understanding of how the product goes together and how each piece affects the others.

RAPID RAIL LINE RAIL KIT

REQUIRED TOOLS

- Power Drill
- 1/8" Drill Bit
- T20 Torx Bit
- Rubber Mallet
- Miter Saw
- Pencil
- Speed Square
- Tape Measure

IMPORTANT NOTES

- Rails should be 3/4" shorter than the span between posts.
- Gap between deck surface and bottom rail = 3"
- Height of top rail = 36" (or 42" for the 42" Rail Kit)
- Horizontal angle (22.5-44.5 degree) and compound angle swivel brackets sold separately.

USE THESE FEATURES FOR RAIL HEIGHT MEASUREMENT

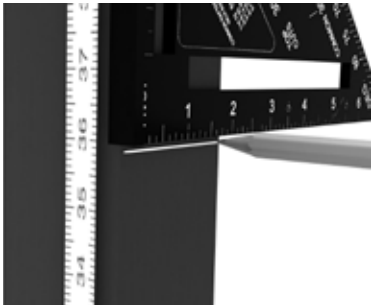
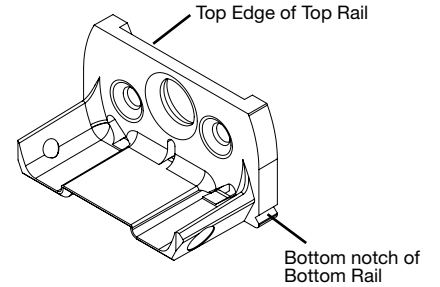

Measure and mark rail heights

- Measure up 36" (42") from the deck surface and make a mark on the post.
- Make a mark at 3" from deck surface for the bottom rail.



Install top brackets

- Align the top surface of the top bracket base with the 36" (42") mark.
- Use a 1/8" drill bit to drill pilot holes using the bracket base as a guide.
- Attach using (2) provided 1" long screws.

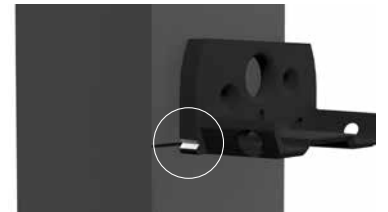

Install bottom brackets

- Align the lower notch of the bottom bracket base with the 3" mark.
- Use a 1/8" drill bit to drill pilot holes using the bracket base as a guide.
- Attach using (2) provided 1" long screws.



Install top and bottom rail bases

- Lower rail bases into brackets.
- Use a 1/8" drill bit to drill pilot holes in the rail base. Use the bracket base as a guide.
- Attach using (4) provided 1/2" screws.



Install bottom rail cap

- The bottom cap rail has baluster cutouts.
- Press cap rail into base rail using rubber mallet if necessary.



Install crush sleeve cap

- Insert crush sleeve cap into one side of the crush sleeve.
- Position crush sleeve under the center hole of the bottom rail.

NOTE: Refer to diagrams above to identify the proper rails.

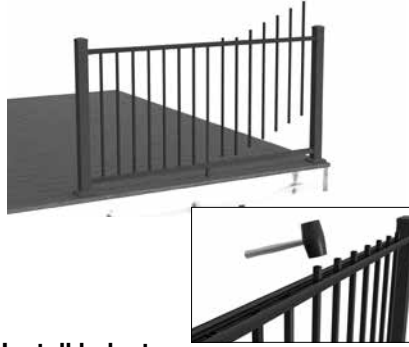
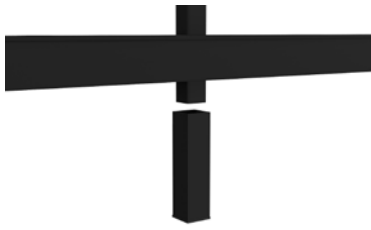

Install center support baluster

- Insert center support baluster through the top and bottom rails and into the positioned crush sleeve.
- Depress button detents to insert through the top rail, ensuring the buttons are parallel to the rail.

Install balusters

- Insert the balusters through the top rail and through the square holes of the bottom rail cap.
- Press the balusters down firmly into the baluster compressor inside the bottom rail.
- Use a rubber mallet to fully seat the balusters into the compressor.

Install top rail cap and bracket caps

- Press the cap rail into the top base rail - use a rubber mallet if necessary.
- Press the bracket caps into place on the bracket bases - use a rubber mallet if necessary.

CUSTOM LENGTH MODIFICATION INSTRUCTIONS

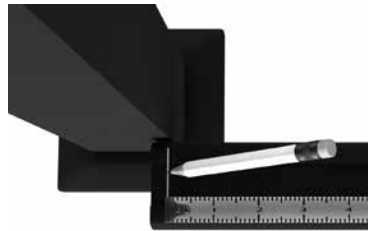

Place rail centered between posts

- Ensure the baluster holes have equal spacing to the posts on both sides.
- **IMPORTANT:** If the gap to the first baluster hole is less than 2", you must shift the rail to one side until the gaps are equal and greater than 2".

Measure 3/8" in from the post and mark the rail on both ends

- This gap is for the bracket clearance.

Transfer marks to all rails and cut

- Use a miter saw equipped to cut aluminum and cut all rails to the same dimensions.
- Both end of the rails will need to be cut to ensure symmetry.

THE DIAGRAMS AND INSTRUCTIONS IN THIS BROCHURE ARE FOR ILLUSTRATION PURPOSES ONLY AND ARE NOT MEANT TO REPLACE A LICENSED PROFESSIONAL. ANY CONSTRUCTION OR USE OF THE PRODUCT MUST BE IN ACCORDANCE WITH ALL LOCAL ZONING AND/OR BUILDING CODES. THE CONSUMER ASSUMES ALL RISKS AND LIABILITY ASSOCIATED WITH THE CONSTRUCTION OR USE OF THIS PRODUCT. THE CONSUMER OR CONTRACTOR SHOULD TAKE ALL NECESSARY STEPS TO ENSURE THE SAFETY OF EVERYONE INVOLVED IN THE PROJECT, INCLUDING, BUT NOT LIMITED TO, WEARING THE APPROPRIATE SAFETY EQUIPMENT. EXCEPT AS CONTAINED IN THE WRITTEN LIMITED WARRANTY, THE WARRANTOR DOES NOT PROVIDE ANY OTHER WARRANTY, EITHER EXPRESS OR IMPLIED, AND SHALL NOT BE LIABLE FOR ANY DAMAGES, INCLUDING CONSEQUENTIAL DAMAGES.