

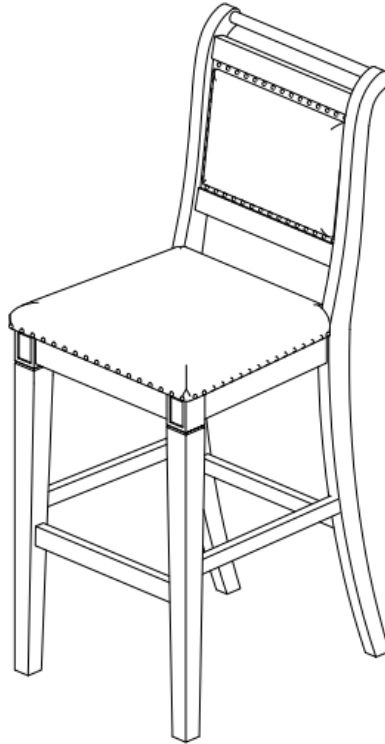

INDOOR LIVING



Centennial Counter/ Bar stool

Item No. IF-1124, IF-1125







For assistance with assembly, please contact DTYStore.com Customer Satisfaction Center
866-217-8155 . CS@DTYStore.com

Made in Vietnam

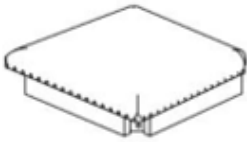





Pre-Assembly Instructions

- Read all instructions carefully before assembly.
- Find a smooth clean area in which to work to avoid damaging your item.
- Check that all parts and hardware from the lists are present.
- Lay out parts in order and hardware in order to make them easier to find when you are ready to assemble
- Wait to dispose of packing material until assembly is complete to avoid accidentally disposing of small parts or hardware
- Tools required: Hex wrench (included) Phillips screwdriver (not included)
- Please use caution and care when lifting the product to avoid injury
- For ease of assembly two people are recommended

Parts List:

<p>A. Back Frame Qty: 1</p> 	<p>B. Seat Frame Qty: 1</p> 	<p>C. Left Front Leg Qty: 1</p> 	<p>D. Right Front Leg Qty: 1</p> 
<p>E. Left Side Stretcher Qty: 1</p> 	<p>F. Right Side Stretcher Qty: 1</p> 	<p>G. Footrest Qty: 1</p> 	

Hardware List:

<p>1. Flat Washer Qty: 11</p> 	<p>2. Spring Washer Qty: 11</p> 	<p>3. 40mm Bolt Qty: 3</p> 	<p>4. 60mm Bolt Qty: 4</p> 
<p>5. Nut Qty: 4</p> 	<p>6. Screw Qty: 6</p> 	<p>7. Wrench Qty: 1</p> 	

Assembly Instructions:

Step 1

Wait to fully tighten all leg hardware until the end of Step 4.

Use three Bolts (3), three Spring Washers (2), and three Flat Washers (1), to **loosely** attach the Seat Frame (B) to the Back Frame (A)

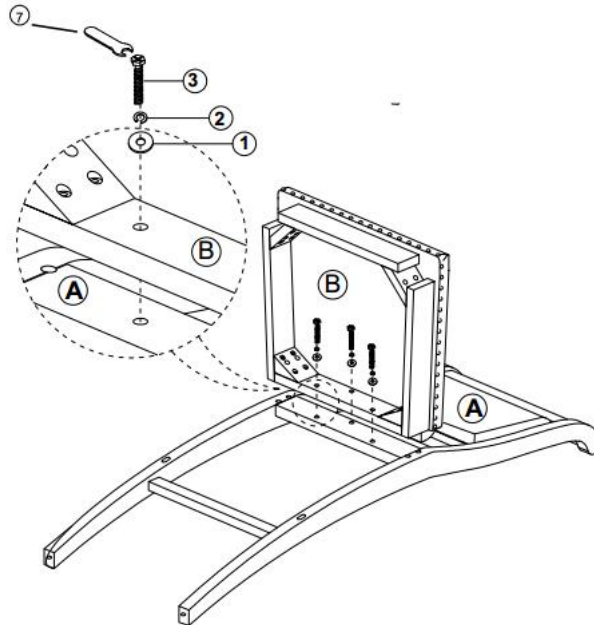

Step 2

- A. Use four Bolts (4), four Spring Washers (2), and four Flat Washers (1), to **loosely** attach the Seat Frame (B) to the Back Frame (A) at the corners
- B. Place the Left Leg Stretcher (E) and the Right Leg Stretcher (G) in the grooves on the Back Frame (A)

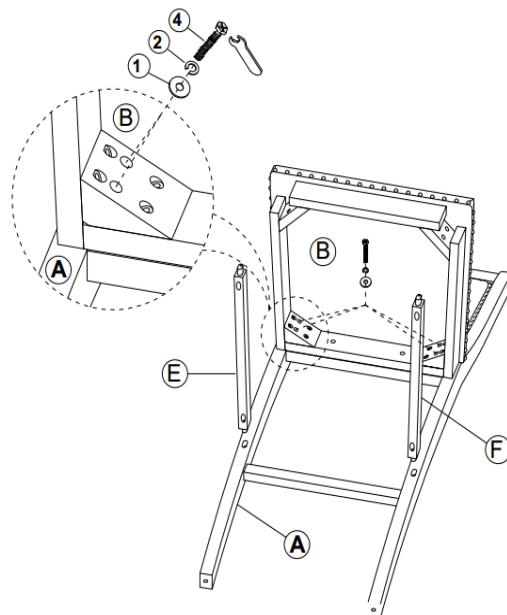

Step 3

A. With Seat (A) upside down on a table, use four Nuts (5) four Spring Washers (2), four Flat Washers (1), to attach the Right Front Leg (C) and Left Front Leg (D) to Seat Frame (B) Do not tighten nuts fully until stretchers and footrest are lined up.

B. Place Footrest (G) in grooves between Right Front Leg (C) and Left Front Leg (D)

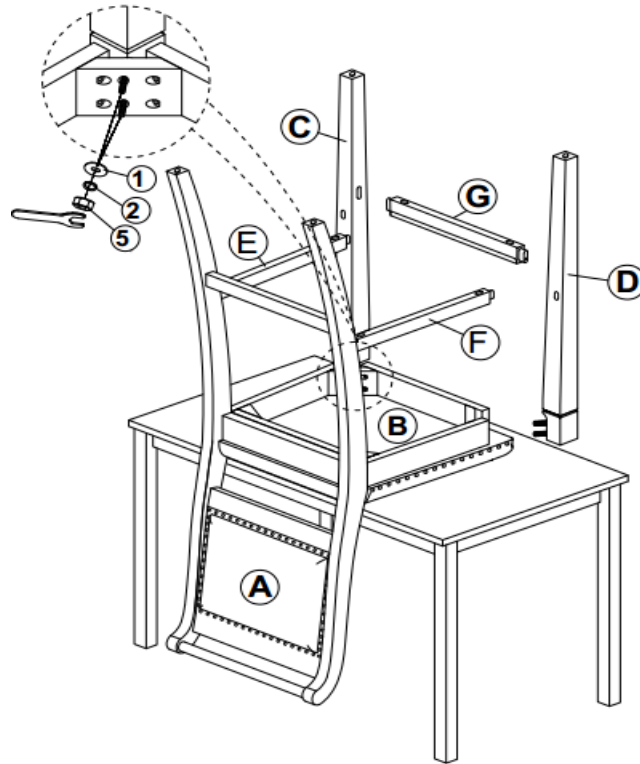

Step 4

A. Use four Screws (6), to attach Left Leg Stretcher (E) between Left Front Leg (D) and back Frame (A) and the Right Leg Stretcher (G) between Right Front Leg (C) and back Frame (A)

TIP: Press both front and back legs against the stretcher bar, tighten the Screws (6) to hold the stretcher bars in place. Make sure the stretcher bar is flush (no gaps) against the leg, this will help with stabilization.

B. Use two Screws (6), to attach Footrest (F) between Left Front Leg (D) and Right Front Leg (C) **TIP: Press both front legs against the footrest, tighten the Screws (6) to hold the footrest in place. Make sure the footrest is flush (no gaps) against the leg, this will help with stabilization.**

C. Tighten all nuts, bolts and screws Do Not Over Tighten

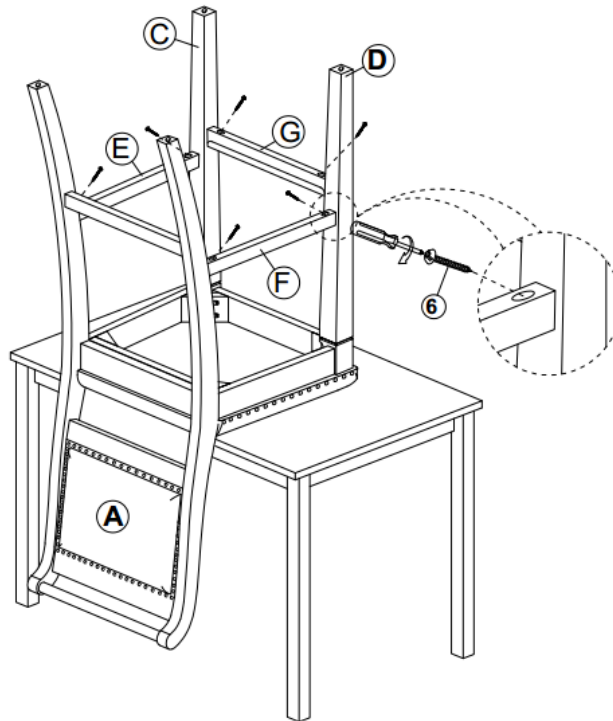

Post-Assembly Instructions:

- Periodically check bolts to be sure they do not loosen over time.
- Do not stand on stool or stretchers.

Furniture Care Tips

With proper care your furniture will look beautiful for years to come.

Wood Furniture Tips

- Avoid placing in direct sunlight to keep from fading and discoloring.
- Do not use soap or abrasive cleaners
- Clean up spills as soon as they occur by blotting the food or liquid and then by wiping with a damp cloth
- Vacuum seat cushions periodically to remove dust and dirt
- Use a soft damp cloth to remove normal dust and dirt from the wood,
- Wood furniture should be dusted frequently. Use a lamb's wool duster, microfiber cleaning cloth or cotton cleaning cloth.
- Dusting with a dry cloth can scratch your furniture so lightly spritz your duster with water, a spray duster or wood polish.
- Never spray polish directly on the furniture as it can cause furniture products to buildup.
- Dust in the direction of the grain

Polyester Upholstery Tips

- Avoid placing in direct sunlight to keep from fading and discoloring.
- Vacuum fabric regularly with an upholstery attachment using low suction.
- Use a soft damp cloth to remove normal dust and dirt
- Wipe up spills immediately, as stains are harder to remove once they are set.
- Most minor stains can be cleaned using 1 tablespoon of dishwashing liquid with 2 cups of cool water. Dab onto the stain with a clean, white cloth. Blot until the liquid is absorbed.
- Never use harsh cleaners.