

**Jewenwils**

# Low Voltage Transformer

SKU:HOSL05E

[Instruction Manual]

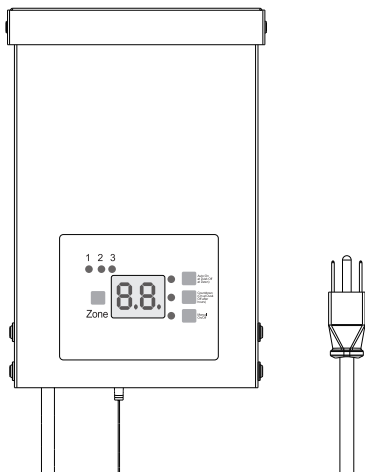

Please pay attention to the warning signs  
Read the instructions with caution before operating  
and keep it properly

V20704

## SAFETY INSTRUCTIONS

Important safety information to reduce risk of fire injury.

1. Do not install within 10 feet (3 m) of a pool, spa or fountain.
  2. There are no serviceable parts inside the power supply unit. **DO NOT DISASSEMBLE.**
  3. Do not repair or tamper with cord or plug.
  4. Do not submerge transformer in water.
  5. Do not mount the transformer onto combustible material.
  6. Do not connect two or more transformers in parallel.
  7. Do not use the transformer with a dimmer switch.
  8. Plug the power supply unit directly into a GFCI wet location outlet.
  9. For use with low voltage outdoor landscape lighting system only.
  10. The maximum output of this transformer is 300 watts. Do not overload the transformer. Be sure that the total cumulative wattage of all 12 volt fixtures connected to the transformer is equal to or less than 300 watts.
- CAUTION:** This landscape light system must be installed in accordance with all local codes and ordinances. If you are experiencing problems, contact a qualified electrician.

## CALCULATE LIGHTING CAPACITY

The 300 Watt transformer has 300 watt circuits which will power up to 300 watts of light. To make sure the maximum number of fixtures can be safely connected to this transformer, add up the individual wattages of all the fixtures. The total wattage of your fixtures must not exceed output capacity of the 300 Watt transformer.

## INSTALLATION

### 1. Preparing the Cable

Being careful when splitting it. NOT to expose the copper cable. Remove the landscape cable insulation 1/2 inch from both cables and twist ends.

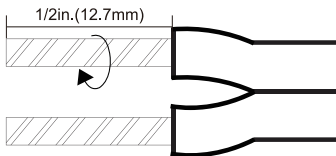

## 2.Connecting the cable to the Transformer

Lay the transformer on a flat, stable surface and use screwdriver to connect the stripped ends of the cable under the terminal clamping plate.

Tips: ① Thread your cable through the white plastic loop to reduce its gravity.

② As the following image shows, there are 3 group wiring ports(COM/12V/14V for each group), you can choose any group of them to connect your cable.

For each group, there are 2 terminal output ends- 12V/14V, select the appropriate terminal according to your lamp voltage.

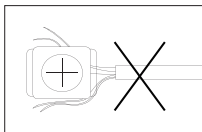
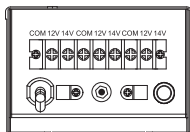

NOTE: Gently pull on the landscape cable to verify if the connection is strong.

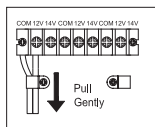

## 3.Placing Your Fixtures and Routing the cable

Lay your fixtures (not included) to your desired location. Be sure they do not exceed the 300-watt rating of the transformer. Coil the rest of the cable after the last fixture.

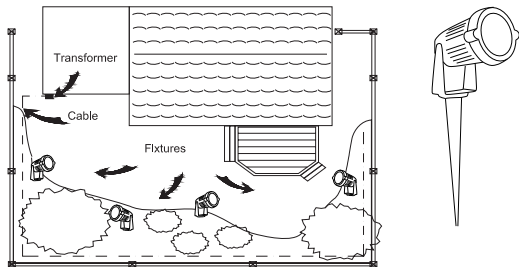

## 4. Attaching Your Fixtures

Use the cable connectors to attach your fixtures with the cable. Plug the transformer in the GFCI outlet and enter the ON mode. Then the lamps will light up.

## 5. Mounting the Transformer

Use the screw to mount the transformer directly on a wall. 12 inch to 48 inch (0.3 m to 1.2 m) high from the ground would be suggested.

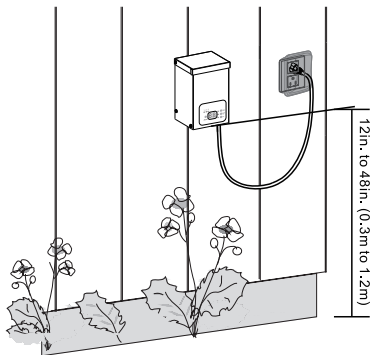

## PRODUCT LAYOUT

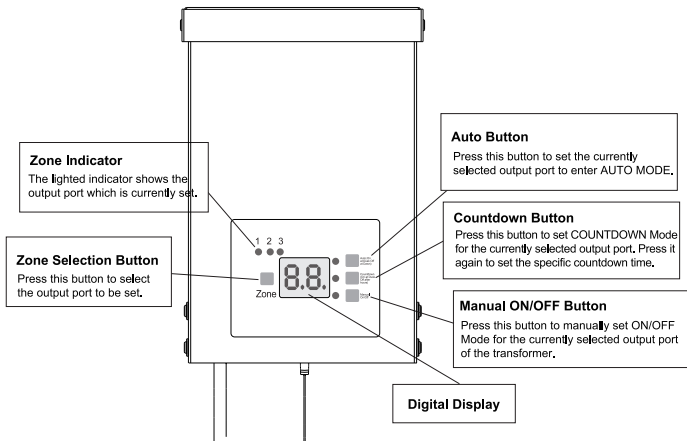

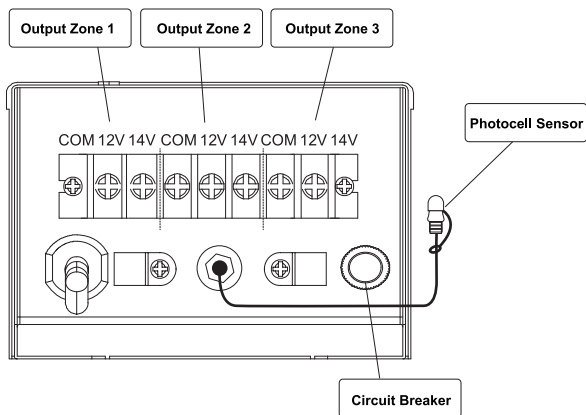

Tips: After completing installation, please remove the cap from the photocell sensor for exposing it to light.

## OPERATING INSTRUCTION

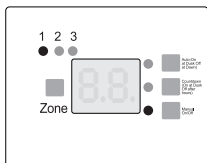

Figure 1

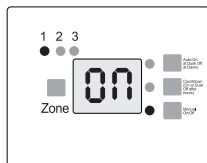

Figure 2

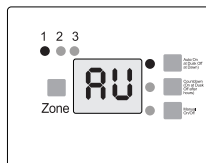

Figure 3

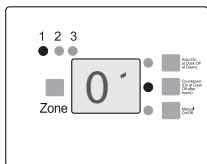

Figure 4

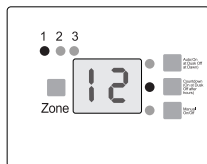

Figure 5

### **Figure 1: OFF MODE**

The currently selected output port of the transformer has no output voltage, and the load lamps do not light up.

### **Figure 2: ON MODE**

The currently selected output port of the transformer will maintain the output through the day, and the load lamps will be always on.

### **Figure 3: AUTO MODE**

In this mode, it will take 0 ~30s for the transformer to detect the external environment firstly. If it is night, the currently selected output port of the transformer will start output later, then the load lamps will light on automatically and off at dawn. If it is during the day, the currently selected output port of the transformer will have no output and the load lamps will not light.

Note: If the light emitted by the load lamps shines on the sensor at night, it may cause the transformer to continuously switch on/off, and the load lamps flash continuously, with a flash interval of 30s.

### **Figure 4 & Figure 5: COUNTDOWN MODE**

In this mode, it will also take 0~30s for the transformer to detect the external environment firstly. If it is night, the currently selected output port of the transformer will start output later and the load lamps will light. Then they will turn off automatically when the the countdown is over. If it is during the day, the currently selected output port of the transformer will have no output and the load lamps will not light.

Note: When the system starts to count down, if the surrounding light shines on the sensor for more than 30s, the countdown will end, the currently selected output port of the transformer will stop output, and the load lamps will go out.

## CABLE SELECTION CHART

| 12 VOLT TAP           | Cable Length |                 |                 |
|-----------------------|--------------|-----------------|-----------------|
| Total Fixture Wattage | 0-50 feet    | 51-100 feet     | 100-150 feet    |
| 0-60 Watts            | 16 AWG       | 16 AWG          | 14 AWG          |
| 61-120 Watts          | 16 AWG       | 14 AWG          | 12 AWG          |
| 121-180 Watts         | 14 AWG       | 12 AWG          | Not Recommended |
| 181-240 Watts         | 14 AWG       | 12 AWG          | Not Recommended |
| 241-300 Watts         | 12 AWG       | Not Recommended | Not Recommended |

| 14 VOLT TAP           | Cable Length        |             |                 |
|-----------------------|---------------------|-------------|-----------------|
| Total Fixture Wattage | 0-50 feet           | 51-100 feet | 100-150 feet    |
| 0-60 Watts            | 16 AWG <sup>1</sup> | 16 AWG      | 16 AWG          |
| 61-120 Watts          | 16 AWG <sup>1</sup> | 16 AWG      | 12 AWG          |
| 121-180 Watts         | 14 AWG <sup>1</sup> | 14 AWG      | 12 AWG          |
| 181-240 Watts         | 14 AWG <sup>1</sup> | 14 AWG      | 12 AWG          |
| 241-300 Watts         | 12 AWG <sup>1</sup> | 12 AWG      | Not Recommended |

AWG<sup>1</sup> Not recommended for Halogen Landscape.



**NOTE:** This data is provided as a general guideline. Actual performance will depend on the installation layout, the fixtures, and the condition of the cable. If the wire diameter you use is thinner than the wire diameter recommended in the table, it may cause the flickering of the end lamps.

## **SPECIFICATIONS**

- Input Voltage: 120VAC, 60Hz
- Output: 12VAC/14VAC
- Max Power Rating: 300W
- Photo Sensor Cable Length: 6 ft

## **PACKING LIST**

- 1× Low-Voltage Transformer
- 2 × Screws
- 2 × Wall Anchors
- 1× Instruction Manual

## **One-year Limited Warranty**

Supported by our professional R&D team and QC team, we provide One Year Warranty for materials and workmanship from the purchase date. Please note that the warranty does not cover damage caused by personal misuse or improper installation.

Please attach your Order ID and Name so that our dedicated customer service team can help you better.