

2200 Lumen LED Dusk to Dawn Security Light

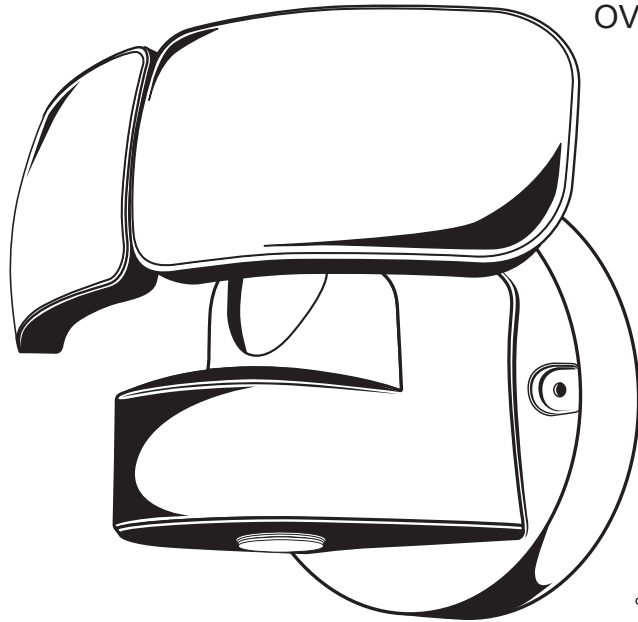

PACKAGE CONTENTS

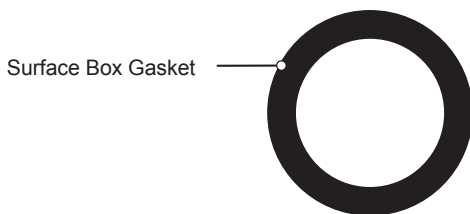
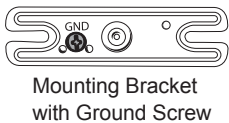
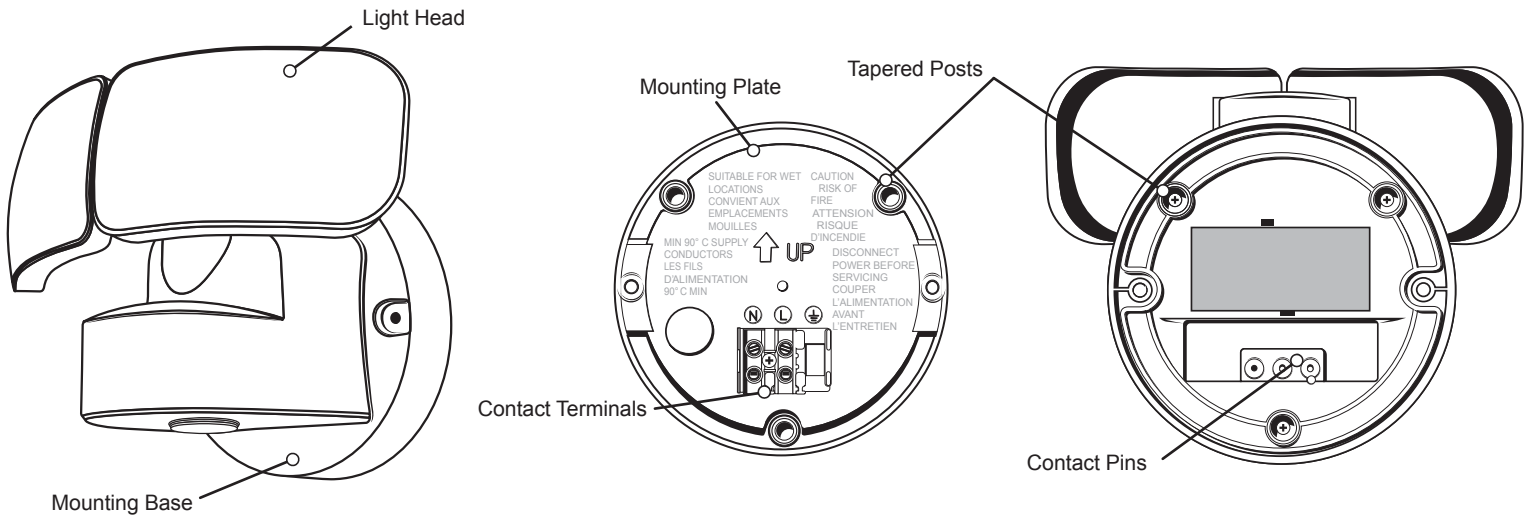

Product Facts:

- Lumens: 2200
- Color temperature: 5000K
- Operating Voltage: 110-240v
- LED Life: 40,000 hours
- Cold start operating temperature: -13° F to 122° F (-25° C to 50° C)

Mount fixture between 6ft.-6in. and 10ft. above the ground.

Electrical requirements can be found on fixture.
Use with a Minimum 90° supply conductors.

This fixture is rated outdoor use.

⚠️ WARNINGS

⚠️ WARNING: TO AVOID ELECTRIC SHOCK, DISCONNECT POWER BEFORE INSTALLING

⚠️ **WARNING:** This product may represent a possible shock or fire hazard if improperly installed or mounted. Products should be installed following these instructions, local electrical codes and/or the current National Electric Code (NEC).

⚠️ **WARNING:** This product needs to be grounded properly in a manner consistent with local electrical codes and/or the current National Electric Code (NEC). If the installer cannot determine if the product is properly grounded, has no ground wire, or is unfamiliar with electrical wiring methods of properly grounding fixture, consult a qualified electrician.

⚠️ **WARNING:** DO NOT alter or disassemble the fixture it is completely enclosed and does not contain replaceable or serviceable parts.

⚠️ **WARNING:** Do NOT mount on ground.

⚠️ **WARNING:** Use only in 110-240V, 60Hz circuits.

⚠️ **WARNING:** Do NOT look directly at LED light sources.

⚠️ **CAUTION:** Personal injury can occur, along with damage to the fixture and/or mounting surface may result if the fixture is pulled from the surface. To prevent premature failure from overheating, fixture should only be installed in environments where the operating temperatures are between -13° to 122°F (-25° to 50° C). Do not install in a totally enclosed (no ventilation) area.

⚠️ SAFETY AND PRECAUTIONS

• Shut off power at the circuit breaker or fuse box before installing or servicing this fixture.

1. Suitable for outdoor use.
2. Do NOT look directly at LED light sources.
3. The LED modules used in this fixture are not serviceable.
4. Do NOT make contact with or install fixture while making contact with water.
5. NOT suitable for ground installations. Do NOT mount below 6.5 ft.
6. This product is inspected prior to shipping. Do not use if product is
7. Suitable for use in operating environments ranging between -13° F to 122° F (-25° C to 50° C).
8. Do NOT leave bare wires exposed outside of the electrical connections.
9. Electrical requirements can be found on back of the fixture.
10. If unsure how to install a light fixture, call a qualified electrician.

ADDITIONAL WARNINGS

This device complies with Part 15 of the FCC rules. Operation is subject to the following two conditions: (1) This device may not cause harmful interference, and (2) this device must accept any interference received, including interference that may cause undesired operation. Warning: Changes or modifications to this unit not expressly approved by the party responsible for compliance could void the user's authority to operate the equipment. The user is cautioned that any changes or modifications not expressly approved by the party responsible for compliance could void the user's authority to operate the equipment. Note: This equipment has been tested and found to comply with the limits for a Class B digital device, pursuant to Part 15 of the FCC rules. These limits are designed to provide reasonable protection against harmful interference in a residential installation. This equipment generates, uses and can radiate radio frequency energy and, if not installed and used in accordance with the instructions, may cause harmful interference to radio communications. However, there is no guarantee that the interference will not occur in a particular installation. If this equipment does cause harmful interference to radio or television reception, which can be determined by turning the equipment off and on, the user is encouraged to try to correct the interference by one or more of the following measures: 1) Reorient or relocate the receiving antenna. 2) Increase the separation between the equipment and receiver. 3) Connect the equipment into an outlet on a circuit different from that of the receiver. 4) Consult the dealer or an experienced radio/TV technician for help.

DIMMING

• DO NOT USE THIS FIXTURE WITH DIMMERS.

Doing so will void the warranty of this product.

CLEANING INSTRUCTIONS

Disconnect power to fixture before cleaning. Using a soft cloth, clean the fixture using a mild, non-abrasive glass cleaner. DO NOT use solvents. DO NOT use cleaners containing abrasive agents. NEVER spray liquid cleaner directly onto the fixture or wiring.

INSTALLATION INSTRUCTIONS

Before beginning, disconnect the power to the junction box. If replacing an existing fixture with more than two wire leads, make a note as to where they were connected.

1. Pull the ends of the supply wires out the front of the junction box. Use the included crossbar screws to fasten the mounting bracket to the junction box. Position the mounting bracket with ground screw facing out (Fig. 1). Tighten down both crossbar screws and attach the junction box ground wire with the green ground screw on the mounting bracket (Fig. 2).

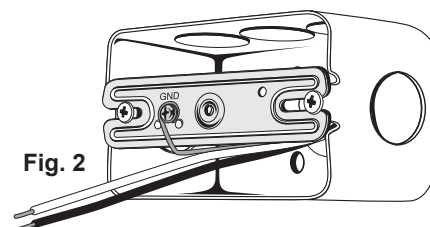
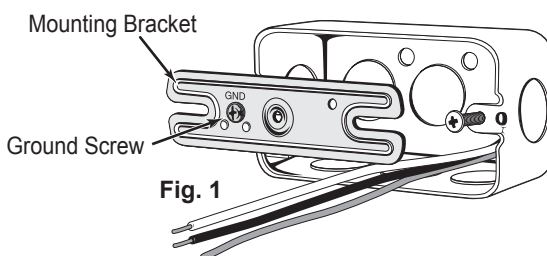

INSTALLATION (CONT.)

2. Feed the ends of the supply wires through the large hole in the mounting plate (ensure that there is enough wire to insert into the contact terminals) (Fig. 3). Line up the center hole (located below the "Arrow" and "UP" molded into the mounting plate) on the mounting bracket. Insert the remaining quick connect screw into the center hole and tighten until the mounting plate is securely attached to the junction box (Fig. 4).

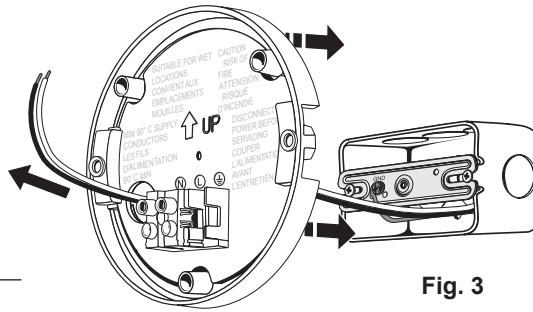

Fig. 3

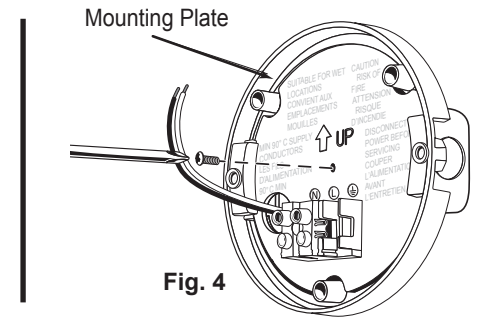

Fig. 4

OPTIONAL

Use the included gasket with a round surface box as a barrier to prevent water seepage into the electrical enclosure

3. Insert the wires into their designated contact terminals (Fig. 5). Insert the **Black Supply Wire** (Live) into the terminal marked "L", insert the **White Supply Wire** (Neutral) into the terminal marked "N" (Fig. 6) and tighten screws to both terminals (Fig. 7).

Ⓛ
Terminal L
LIVE

Ⓝ
Terminal N
NEUTRAL

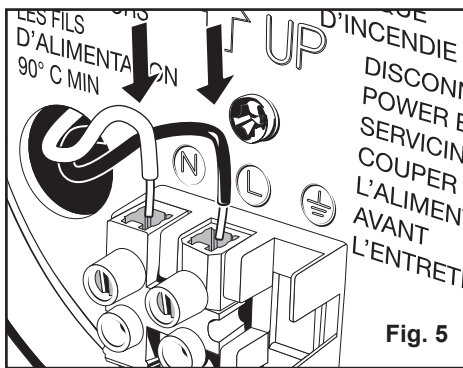

Fig. 5

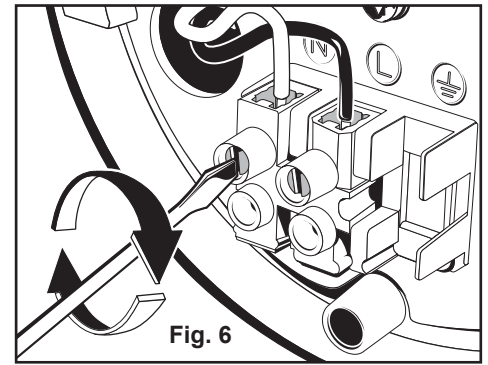

Fig. 6

4. The security light fits onto the mounting plate in a specific manner. There are three (3) tapered posts on the mounting plate, two toward the top and one at the bottom. They fit into three (3) corresponding holes on the back side of the mounting base of the fixture (Fig. 7). Line the holes and posts up and guide the fixture onto the mounting plate already attached to the junction box. There are also 2 contact pins that align and will engage the contact terminal block on the mounting plate (Fig. 8).

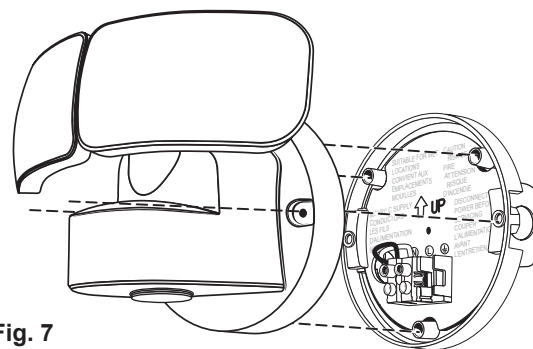

Fig. 7

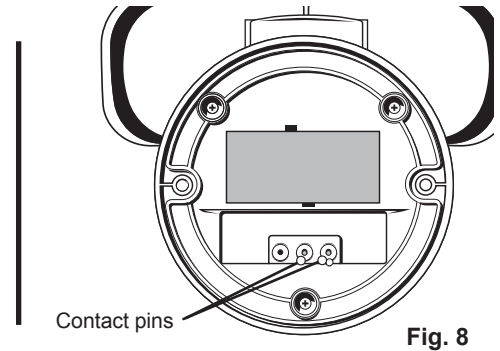

Fig. 8

5. Insert the 2 short stainless steel screws through the 2 holes on each side of the mounting base and secure the fixture to the junction box (Fig. 9). Restore the power to the junction box. Make sure the wall switch that controls the electrical box for the security light is returned to the "ON" position and check that the light is functioning properly.

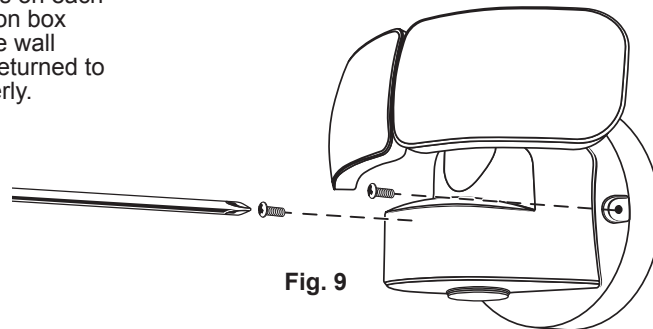

Fig. 9

OPTIONAL

6. Use silicone seal/caulking (not included) to seal-off around the mounting plate and the mounting surface to add an additional barrier to prevent water seepage into the electrical enclosure.

LIGHT HEAD OPERATION

1. The light head can pivot about 85° up and down about 45° (Fig.11). Each individual light head can rotate right or left up to 60° in order to aim light in a multitude of angles (Fig.12). Rotating beyond the set range will damage the fixture and could lead to an unsafe situation.

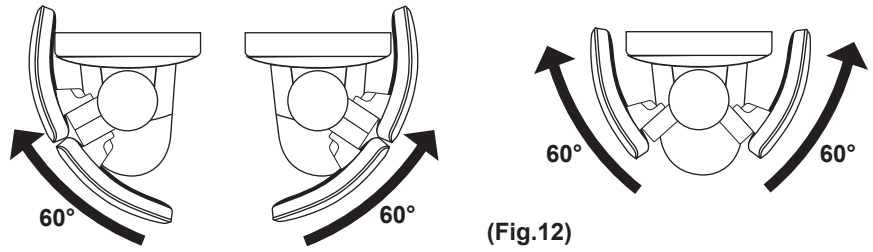
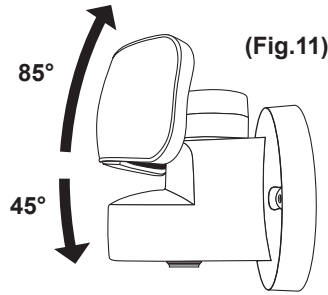

TROUBLESHOOTING GUIDE

Before starting any work on the fixture, shut off power supply at the circuit breaker panel to avoid electrical shock.

Problem	Probable Cause	Solution
Fixture does not turn on.	<ol style="list-style-type: none"> 1. Bad connection. 2. Faulty switch. 3. Power is off. 	<ol style="list-style-type: none"> 1. Check wiring connections. 2. Test switch or replace it. 3. Verify power supply is on.
Light comes on during the daylight hours.	<ol style="list-style-type: none"> 1. Fixture may be located in a shaded area; dusk-to-dawn sensor is detecting darkness. 2. Dusk-to-dawn sensor may be malfunctioning. 	<ol style="list-style-type: none"> 1. Shine a light at the dusk-to-dawn sensor. If the security light immediately shuts off, then the fixture is located in an area that is too dark to allow enough light to enter the sensor. The light will need to be relocated. 1. Email customer service at info@stonepointledlighting.com. 2. Call an electrician..
Light cycles ON and OFF continuously (strobe light effect).	<ol style="list-style-type: none"> 1. Dusk-to-dawn sensor is detecting reflected light from the security light. 	<ol style="list-style-type: none"> 1. Change the position of the light head. Reposition light away from the reflecting surface. 2. Move the light to a different location where the results are better.
Light does not come on during night time hours.	<ol style="list-style-type: none"> 1. Fixture is located in a lighted area; dusk-to-dawn sensor is detecting light. 2. Sensor is blocked. 	<ol style="list-style-type: none"> 1. Cover the dusk-to-dawn sensor. If the security light immediately turns on, then the fixture is located in an area that is too close to a light that interferes with the sensor. The light will need to be relocated. 2. Clear obstructions in front of sensor or relocate light.
Circuit breaker trips or fuse blows when light is turned on.	<ol style="list-style-type: none"> 1. Discontinue use immediately. 	<ol style="list-style-type: none"> 1. Email customer service at info@stonepointledlighting.com. 2. Call an electrician.

3 YEAR LIMITED WARRANTY

This product is guaranteed against failure due to factory defects on materials or workmanship for three (3) years from the date of purchase. This warranty is non-transferable and applies only to the original owner. Proof of purchase is required for repair or replacement. This warranty does not cover normal wear of parts or damage resulting from any misuse of the product. Misuse of the product includes, but is not limited to: washing the product, using in extreme weather conditions, opening the product, or trying to remodel the product. Important: this warranty is only valid if the product has been purchased through an authorized reseller.

CUSTOMER SERVICE

For questions regarding this product, please e-mail us at info@stonepointledlighting.com.