

**EASY
SPACE**

ES-020

Dimension:
918 x 1256 x 2026 mm

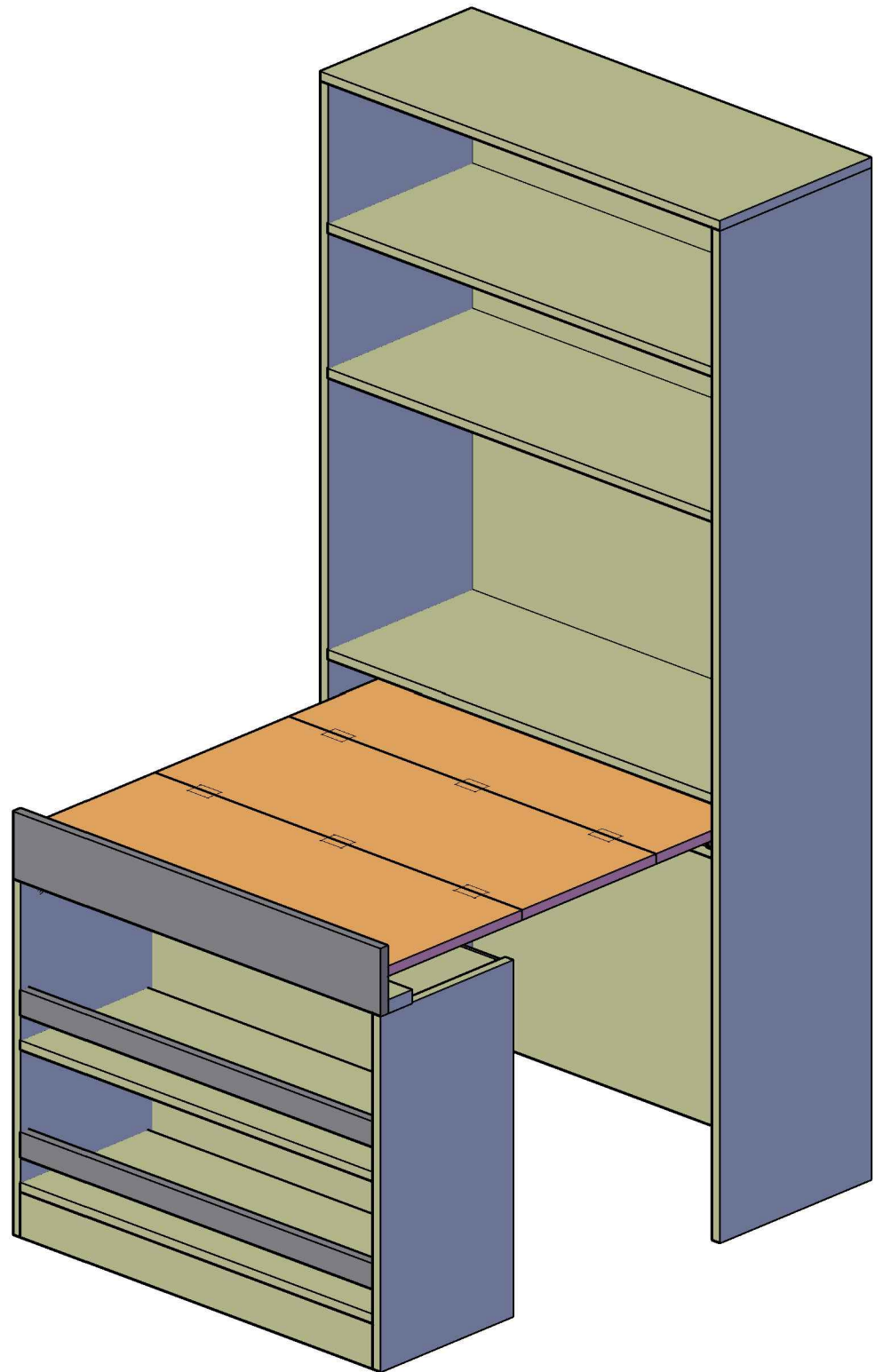

Assembly Guide

Step 1

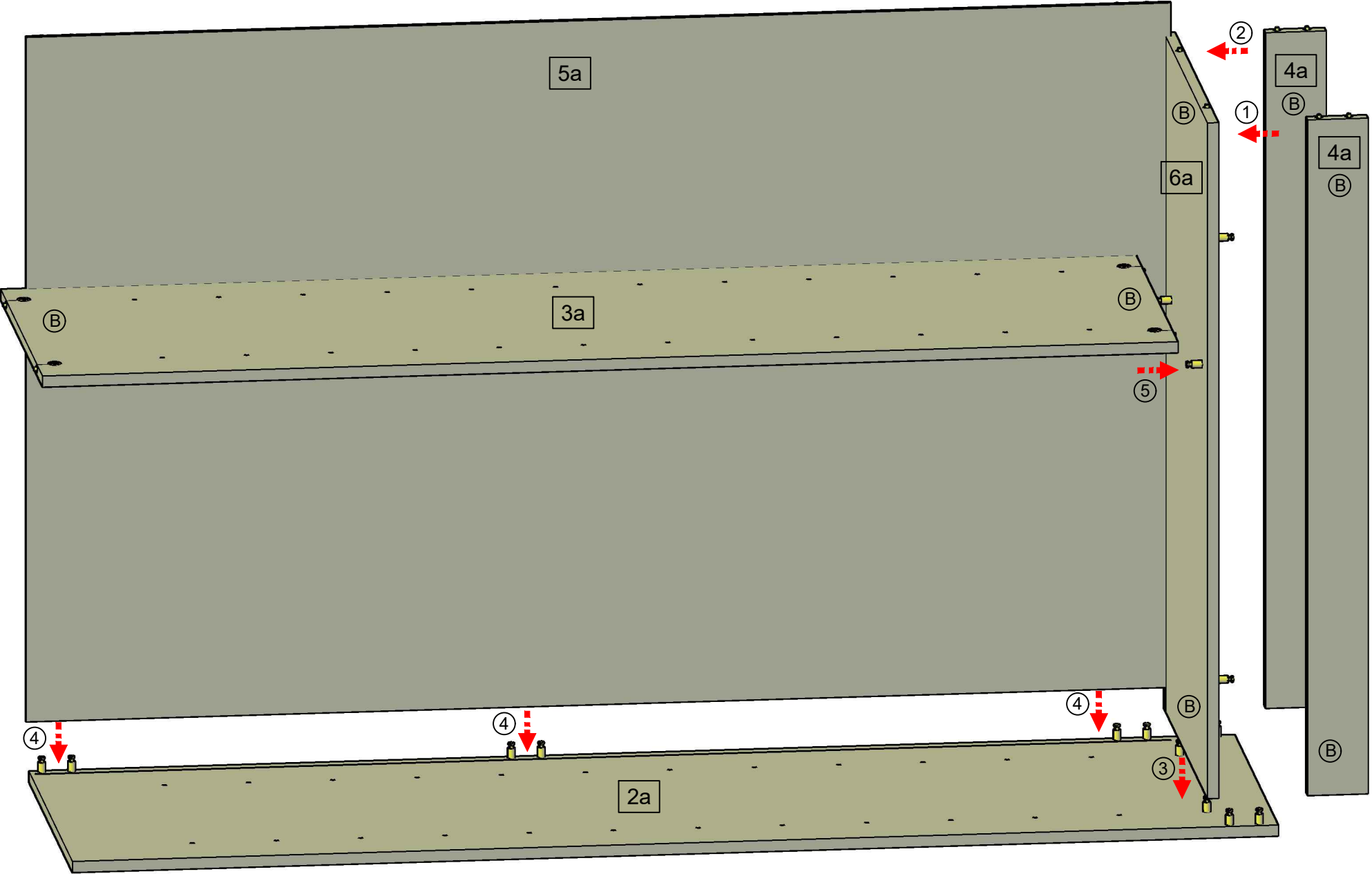

Assembly Guide

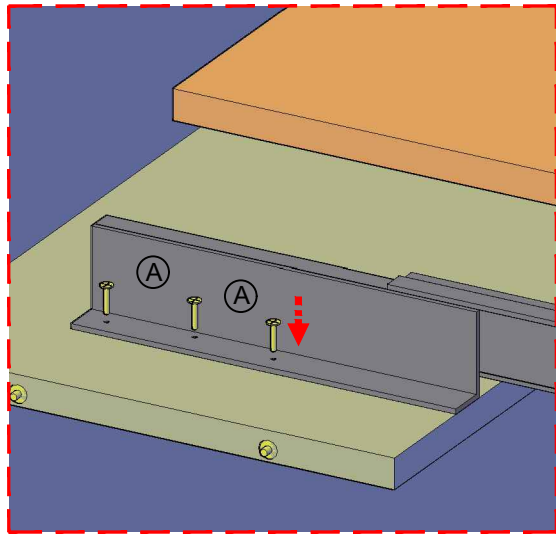

Step 1

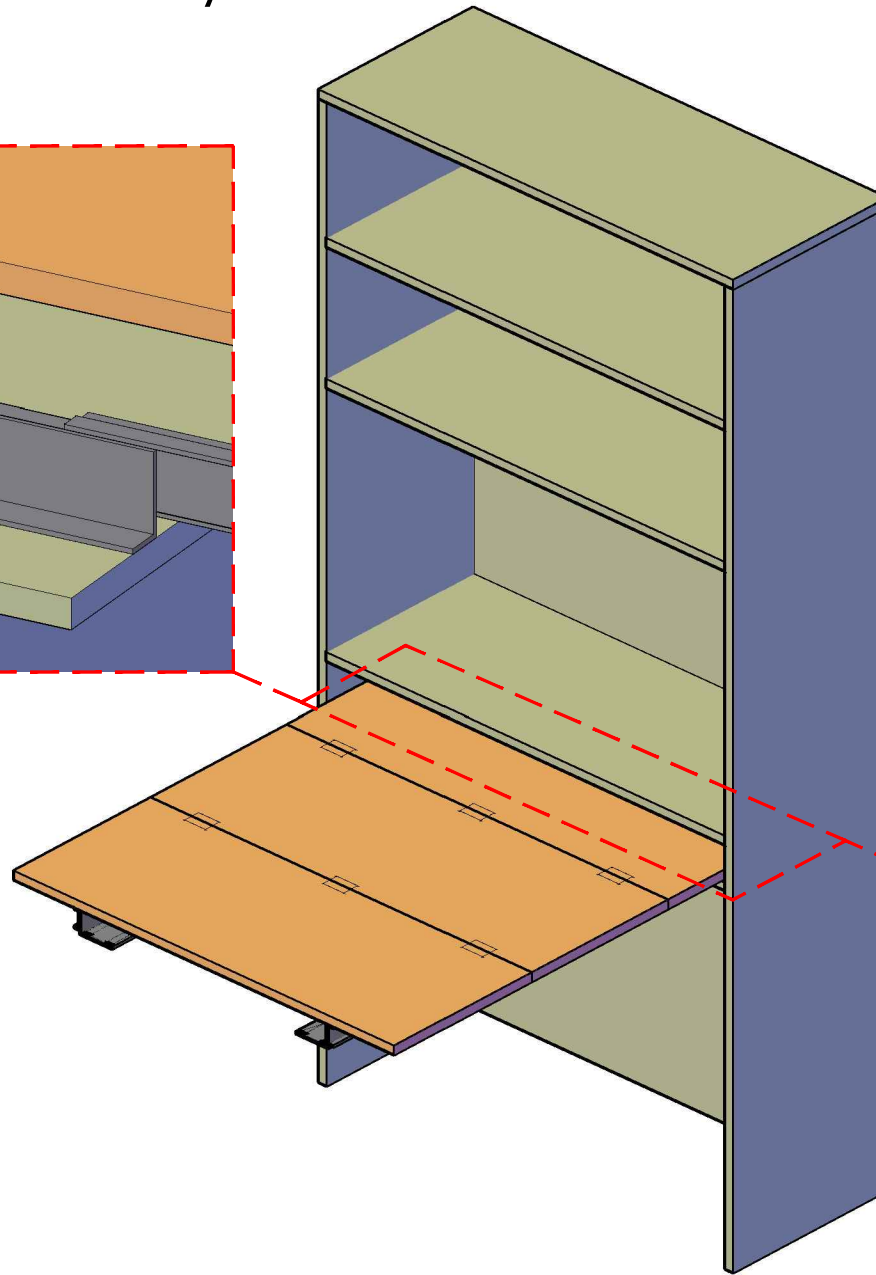

ACCESSORIES:



TOOLS:

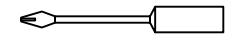

SCREW DRIVER

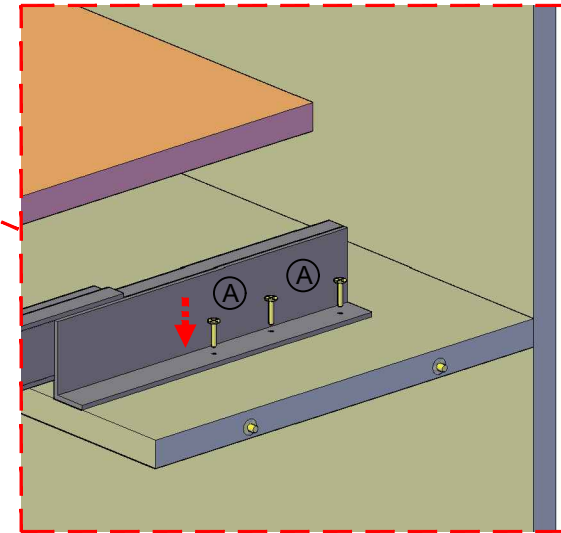

Step 2

Assembly Guide

Step 3

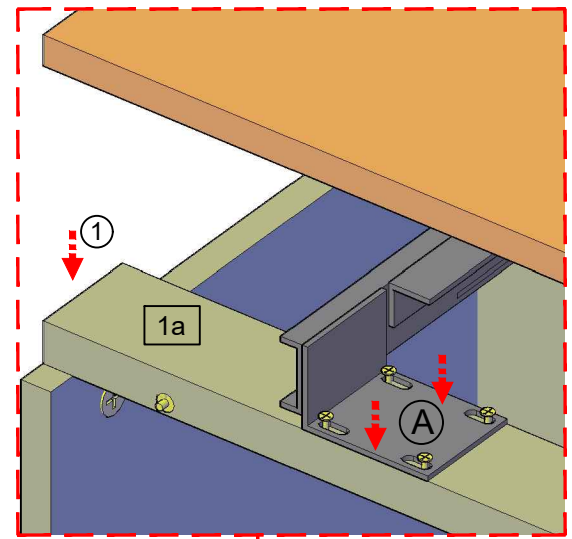

HOW TO USE CAMLOCK & PIN:

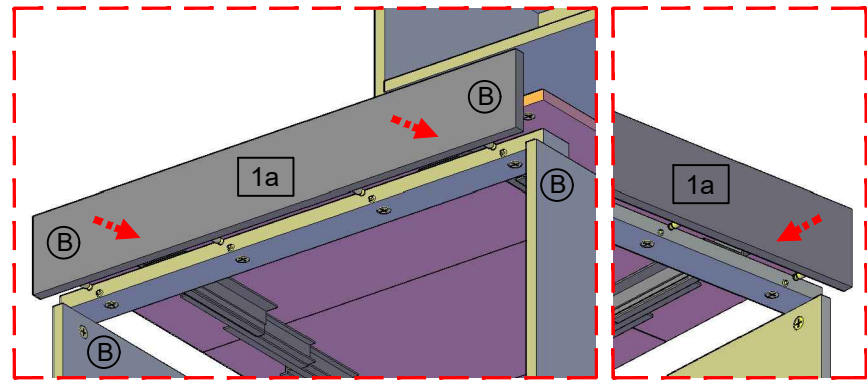
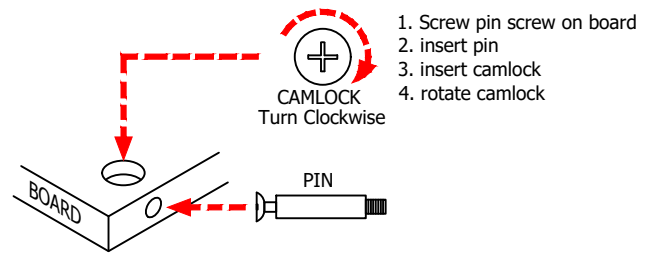

Step 4

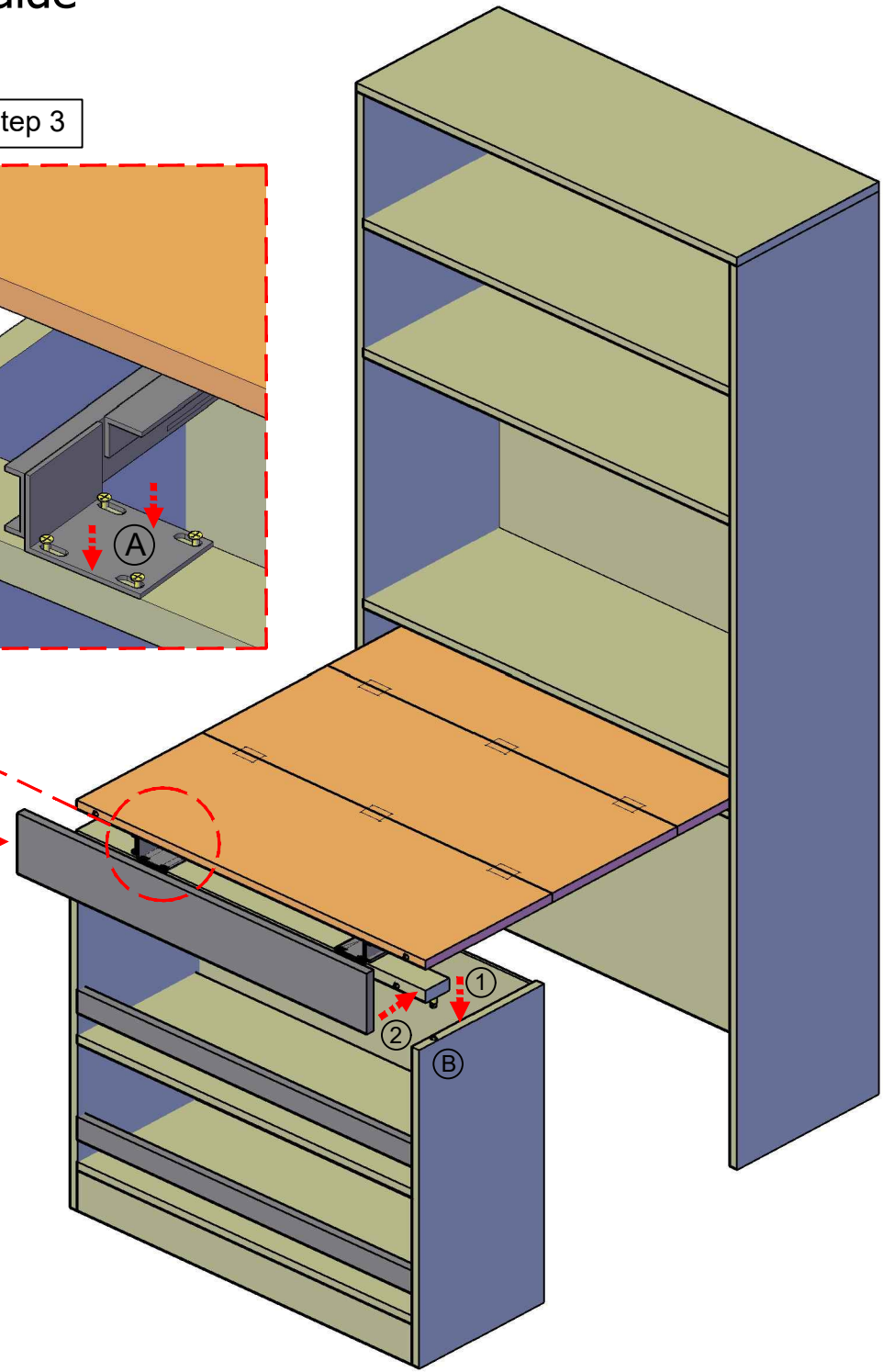

ACCESSORIES:

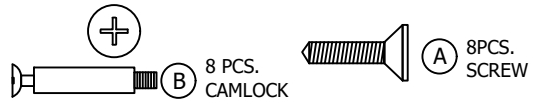

Parts List:
1a. Base Panel Board 2pcs.

TOOLS:

