

# Assembly Guide

Step 1

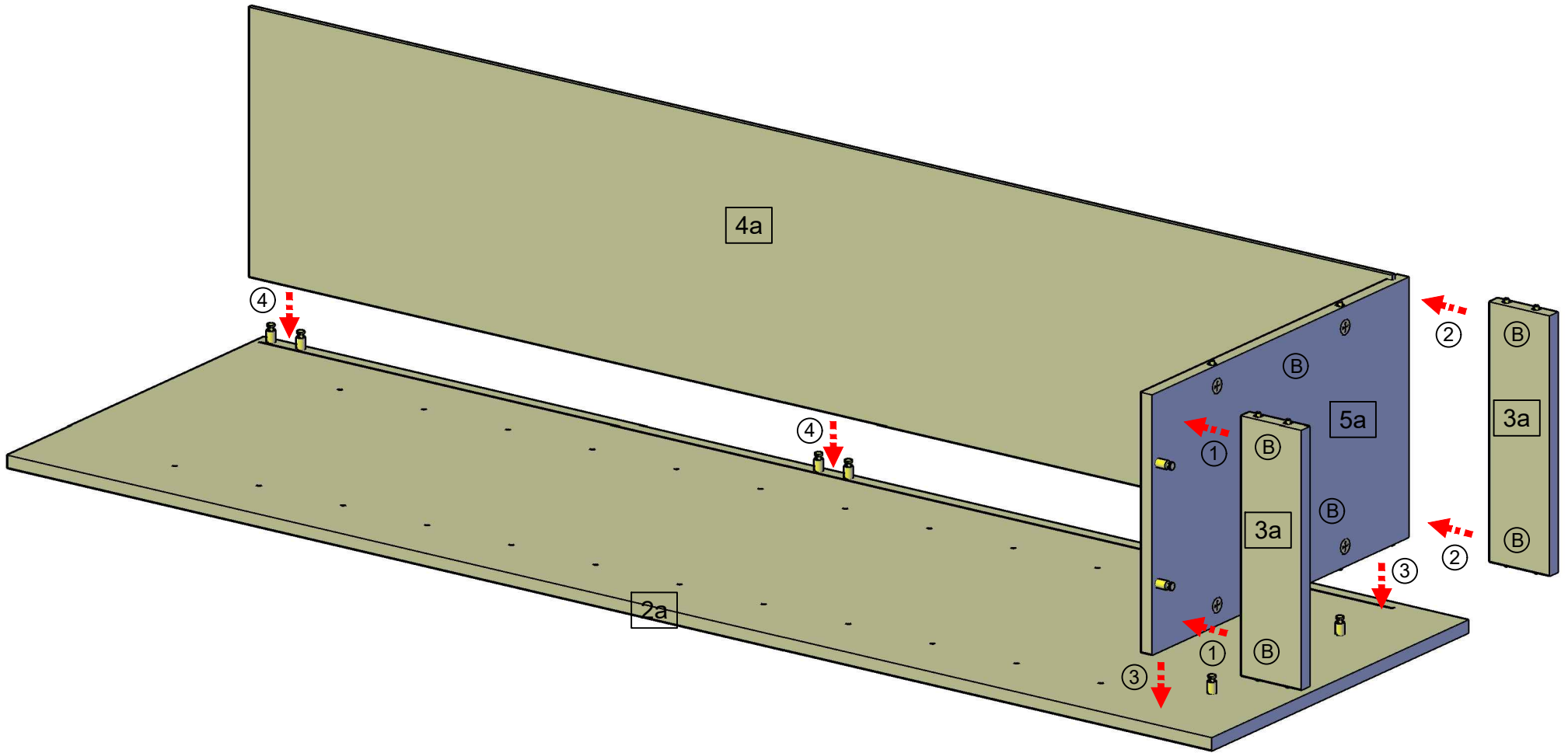

## Parts List:

- 1a. Top Panel Board x 1pc.
- 2a. Left & Right Panel Board x 2pcs.
- 3a. Base Panel Board x 4pcs.
- 4a. Back Panel Board x 1pc.
- 5a. Bottom Panel Board x 1pc.
- 6a. Shelf Panel Board x 6pcs.

## ACCESSORIES:

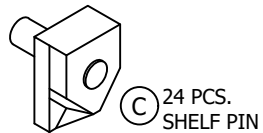
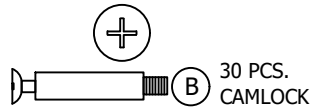

## TOOLS:

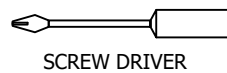

## HOW TO USE CAMLOCK & PIN:

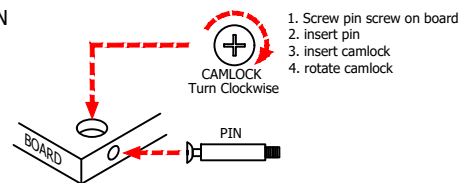

# Assembly Guide

Step 2

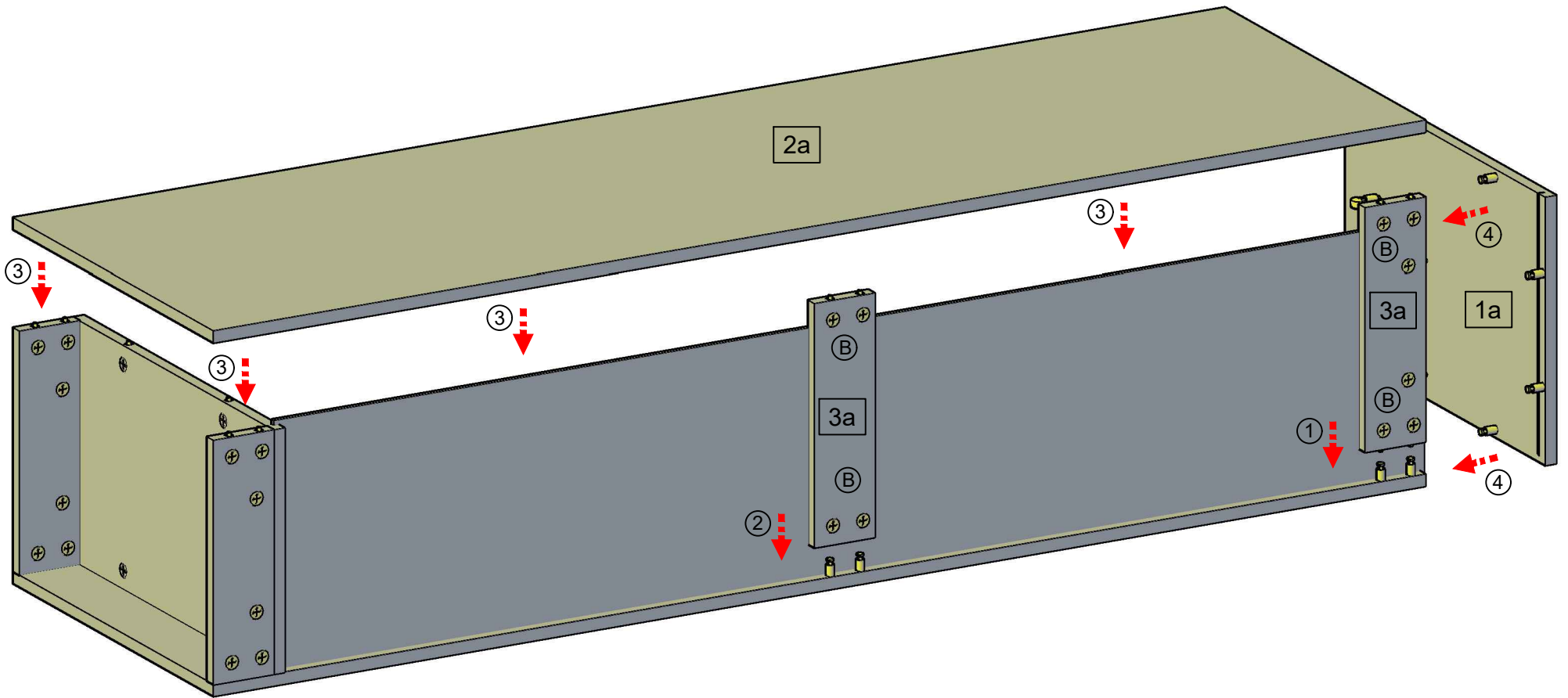

# Assembly Guide

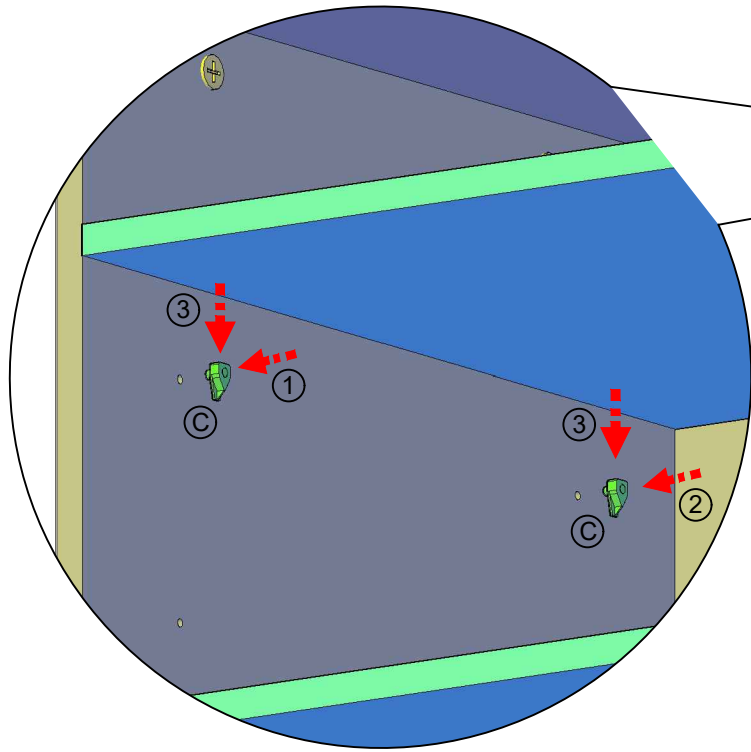

Step 4

## ACCESSORIES:

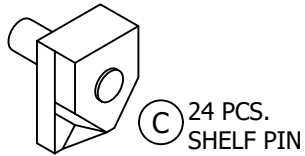
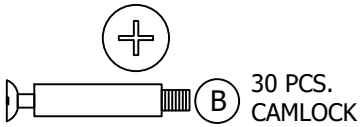

## TOOLS:

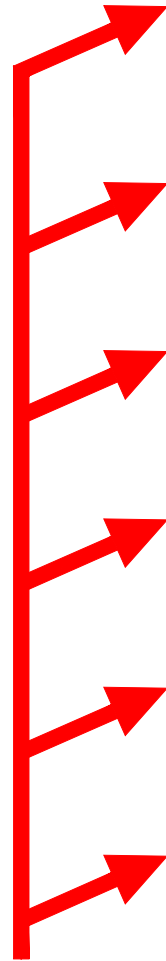

ADJUSTABLE  
SHELVES

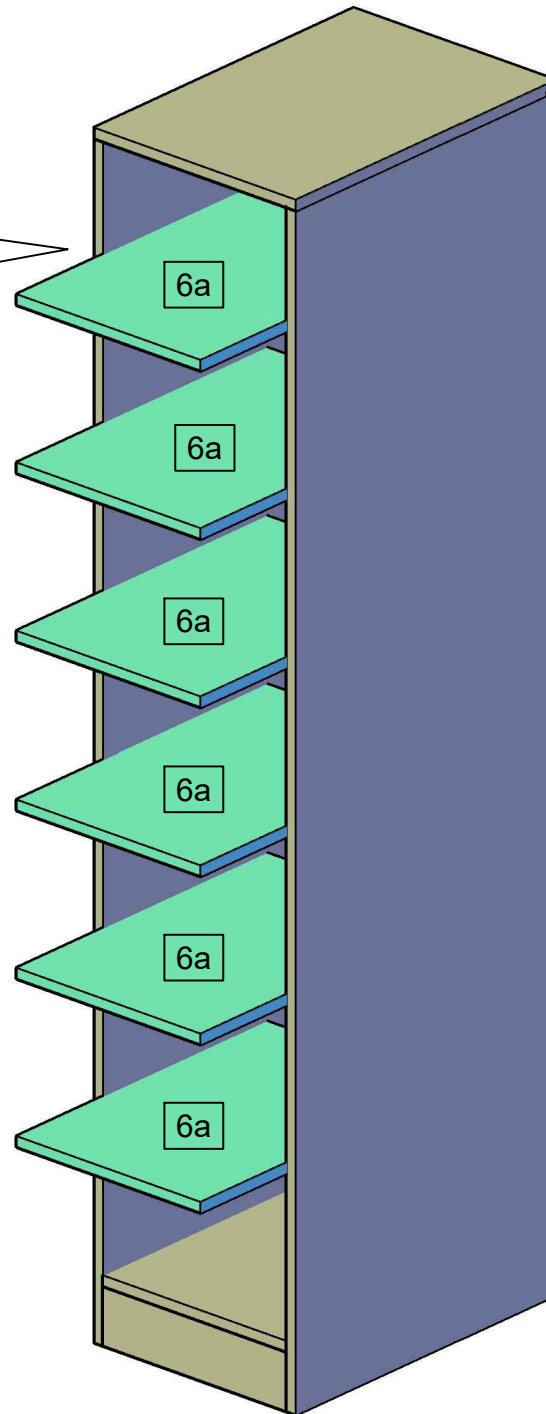

Step 3

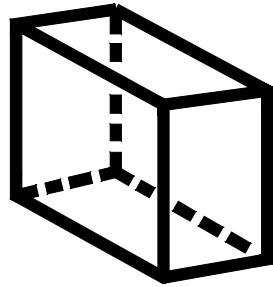

**EASY  
SPACE**

**ES-007**

Dimension:  
410 x 600 x 2026 mm

