

UNLESS OTHERWISE SPECIFIED:
DIMENSIONS ARE IN MILLIMETERS

TOLERANCES:

ANGULAR: MACH: \pm .1°
BEND: \pm .5°
NO DECIMAL: \pm 1.0mm
ONE PLACE DECIMAL: \pm .50mm
TWO PLACE DECIMAL: \pm .25mm
THREE PLACE DECIMAL: \pm .100mm

PROPRIETARY AND CONFIDENTIAL

THE INFORMATION CONTAINED IN THIS
DRAWING IS THE SOLE PROPERTY OF
VERMONT SPORTSCAR. ANY
REPRODUCTION IN PART OR AS A WHOLE
WITHOUT THE WRITTEN PERMISSION OF
VERMONT SPORTSCAR IS PROHIBITED.



THIRD ANGLE PROJECTION



DESCRIPTION:

VSC 14 mm HEAD STUD KIT

VSC ITEM NUMBER:

VSCR-A-020

DO NOT SCALE DRAWING

COMMENTS: CYLINDER BLOCK MODIFICATION

FINISH:

SHEET 1 OF 2

NOTES:

- PLEASE NOTE, THE SPARK PLUG THREADS ARE NOT LOCATED IN THE CENTER OF THE COMBUSTION CHAMBER OR THE CYLINDER HEAD STUD BOLT PATTERN
- THE SPARK PLUG THREADS ARE 2 mm CLOSER TO THE EXHAUST PORTS.

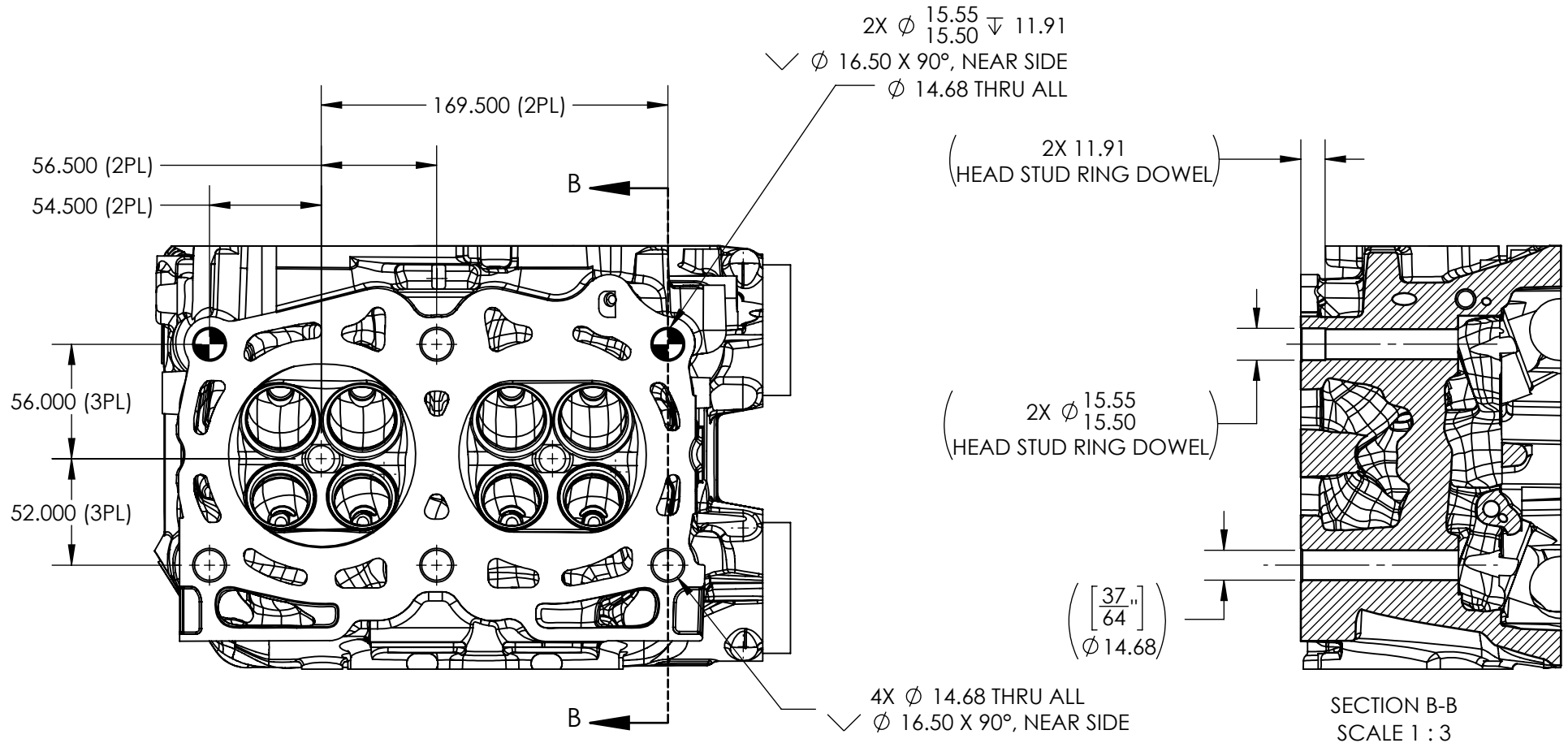

UNLESS OTHERWISE SPECIFIED:
DIMENSIONS ARE IN MILLIMETERS

TOLERANCES:

- ANGULAR: MACH: ± .1°
- BEND: ± .5°
- NO DECIMAL: ± 1.0mm
- ONE PLACE DECIMAL: ± .50mm
- TWO PLACE DECIMAL: ± .25mm
- THREE PLACE DECIMAL: ± .100mm

PROPRIETARY AND CONFIDENTIAL

THE INFORMATION CONTAINED IN THIS DRAWING IS THE SOLE PROPERTY OF VERMONT SPORTSCAR. ANY REPRODUCTION IN PART OR AS A WHOLE WITHOUT THE WRITTEN PERMISSION OF VERMONT SPORTSCAR IS PROHIBITED.



THIRD ANGLE PROJECTION



DESCRIPTION:

VSC 14 mm HEAD STUD KIT

VSC ITEM NUMBER:

VSCR-A-020

DO NOT SCALE DRAWING

COMMENTS: CYLINDER HEAD MODIFICATION

FINISH:

SHEET 2 OF 2