

CP02 Series Canopy Light

Fuel Pump Canopy

OVERVIEW

| | |
|--------------------------------|---|
| Wattage (W) | 75/56/37/22W Selectable 100/75/50/30W Selectable 120/90/60/36W Selectable |
| Lumen Package (lm) | Up to 18,000 lm |
| Color Temperature (CCT) | 3000K/4000K/5000K Selectable |
| Efficacy (lm/W) | 150 lm/W |



DETAILS

Designed for gas stations, parking garages, toll stations, and many other outdoor covered areas, this canopy light features frosted tempered glass for brilliant lighting with reduced glare. Its housing is IP65 rated to withstand dust and water jets, and it carries an IK08 rating for impact protection.

KEY FEATURES

- Lumen Output Up to 18,000 lm
- Power & CCT Selectable
- Stock one SKU for different applications
- Multiple Installations
- IP65 & IK08 double protection

DIP SWITCH

Using the DIP switches on the fixture, the driver can be set to operate at 30%, 50%, 75% or 100% power, and the CCT can be set to Cool White (CW), Natural White (NW), or Warm White (WW).

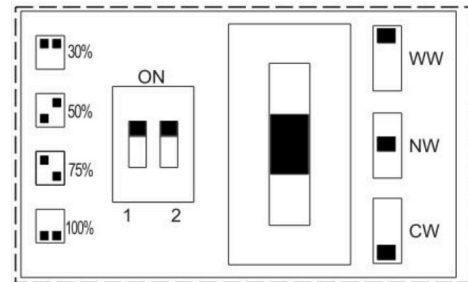

APPLICATIONS

- Gas Station
- Underground Parking Lot
- Warehouse
- Industrial Facility
- Exhibition Center
- Shopping Mall
- Toll Station

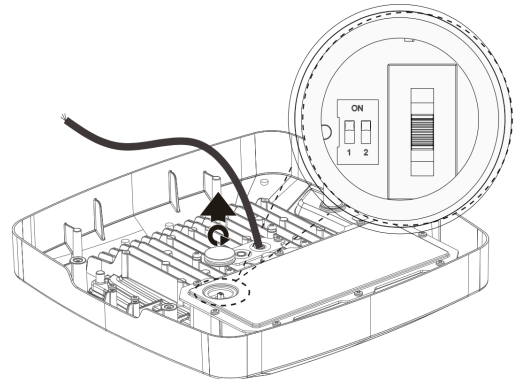

CP02 Series Canopy Light

Fuel Pump Canopy

SPECIFICATIONS

| | |
|------------------------------|--|
| Wattage & Lumens | 75/56/37/22W Selectable, Up to 11,250 lumens 100/75/50/30W Selectable, Up to 15,000 lumens 120/90/60/36W Selectable, Up to 18,000 lumens |
| Efficacy | 150 lm/W |
| CCT | 3000K/4000K/5000K Selectable |
| CRI (Ra) | 70 |
| Controls | 0-10V Dimming CCT & Power Selectable Auxiliary Motion Sensor |
| Input Voltage | 120-277VAC, 50/60Hz |
| Power Factor | >0.9 |
| LED Type | LED 2835 |
| Average Lifetime | L90: 45,000 hours L80: 93,000 hours L70: 148,000 hours |
| Beam Angle | 120° |
| Mounting | Surface Mount Surface Mount with Adapter Plate* (*optional accessory) Conduit Mount with G 3/4 Adapter Plate* (*optional accessory) |
| Operating Temperature | -30°C to 50°C (-22°F to +122°F) |
| Material | ADC12 Aluminum Housing, Tempered Glass Lens |
| Fixture Color | White |
| Finish | Powder Coating |
| Surge Protection | 6kV line-line, 10kV line-earth |
| IP Rating | IP65 |
| IK Rating | IK08 |
| Certifications | DLC Premium, ETL |
| Warranty | 5 Years |

CP02 Series Canopy Light

Fuel Pump Canopy

ORDERING GUIDE

Example: **LLTVCP02-075WCS-7S-120C-PR**

| SKU Root | Wattage / Lumens | CCT | CRI | Lens | Sensor |
|------------------|--|------------------------------------|---|--|--|
| LLTVCP02- | 075W - 75/56/37/22W Selectable, Up to 11,250 lumens 100W - 100/75/50/30W Selectable, Up to 15,000 lumens 120W - 120/90/60/36W Selectable, Up to 18,000 lumens | CS - 4000K/5000K Selectable | -7S - 70 (Standard) -8S - 80 | -120C - Clear -120F - Frosted | PR - PIR Motion MM - Microwave Motion |

PRODUCT DIMENSIONS

| DIMENSIONS | |
|---|--|
| Product Dimension (Without Sensor - Standard) | 369.5 x 368.5 x 65mm (14.55" x 14.51" x 2.56") |
| Product Dimension (With Sensor) | 369.5 x 429 x 65mm (14.55" x 16.89" x 2.56") |
| Luminaire Net Weight | 3.9±0.3kg (8.60±0.66 lbs) |
| Export Carton Size | 390 x 390 x 90mm (15.35" x 15.35" x 3.54") |
| Gross Weight | 4.63±0.3kg (8.81±0.66 lbs) |

Without Sensor (Standard)

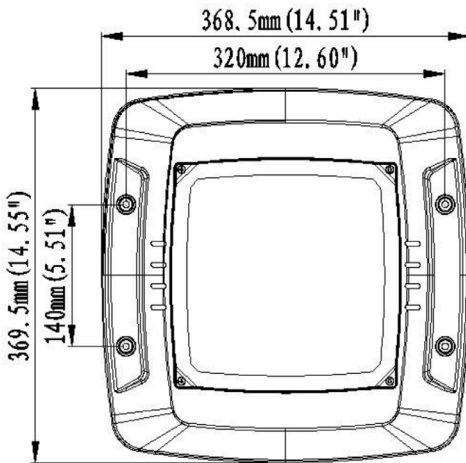

With Sensor

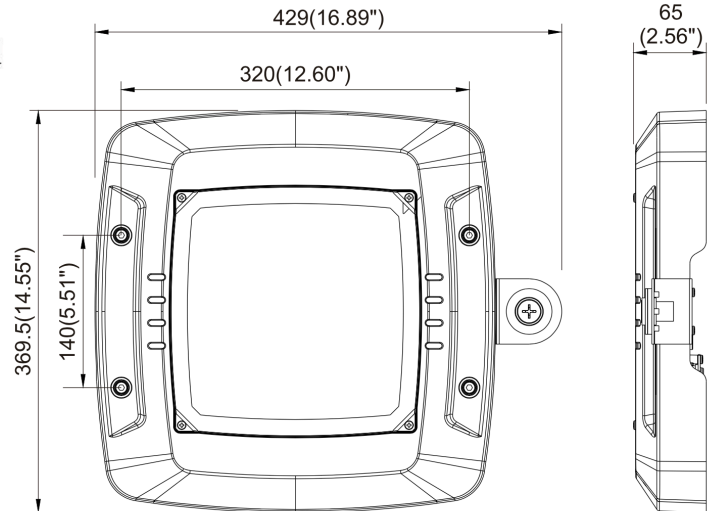

CP02 Series Canopy Light

Fuel Pump Canopy

PERFORMANCE

| Model | Setting | Distribution | CRI | Lumens | Wattage | Efficacy |
|-----------------|---------|--------------|-----|--------|---------|----------|
| LLTVCP02-075WCS | 75W | 120 | 70 | 11,250 | 75 | 150 |
| LLTVCP02-100WCS | 100W | 120 | 70 | 15,000 | 100 | 150 |
| LLTVCP02-120WCS | 120W | 120 | 70 | 18,000 | 120 | 150 |

PHOTOMETRICS

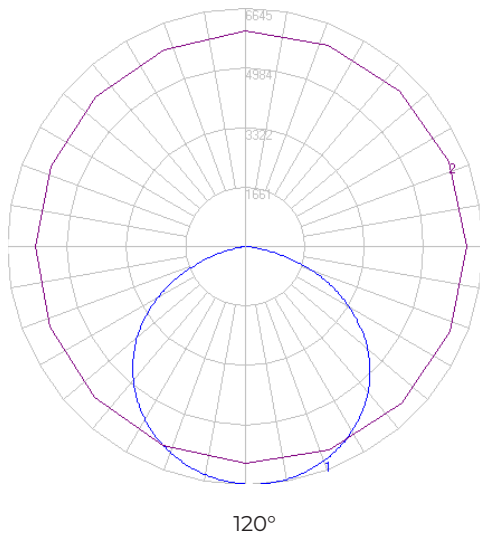

CP02 Series Canopy Light

Fuel Pump Canopy

MOUNTING

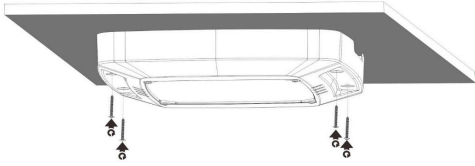

Surface Mount

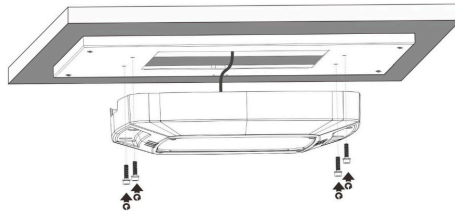

Surface Mount with Adapter Plate*
(*available as an optional accessory)

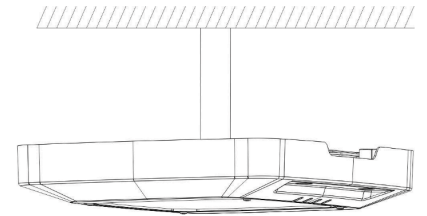

G 3/4 Conduit Mount*
(*available as an optional accessory)

MOTION SENSOR ASSEMBLY

1. ✖

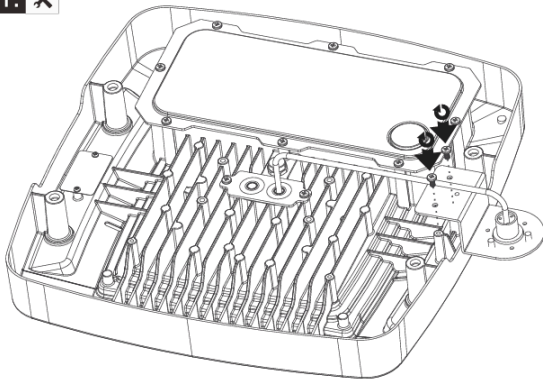

WITH
2PCS
1.2Nm

2. ✖

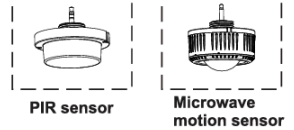
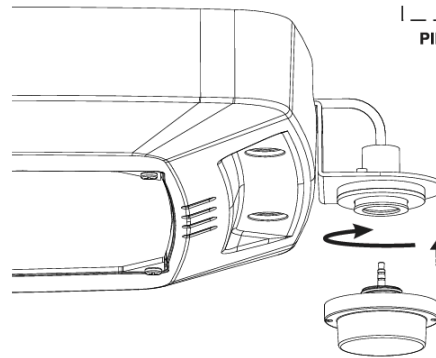

PIR sensor

Microwave
motion sensor

ACCESSORIES

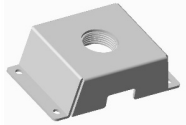
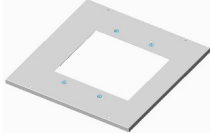
| SKU | Description | Image |
|---------------------|-----------------------------|---|
| LLTACP02-ADPTR-G3/4 | G 3/4 Adapter Plate |  |
| LLTACP02-MTPLT01 | Ceiling Mount Adapter Plate |  |