

3445MAX and 345MAX Series Air Grinder- Exploded View

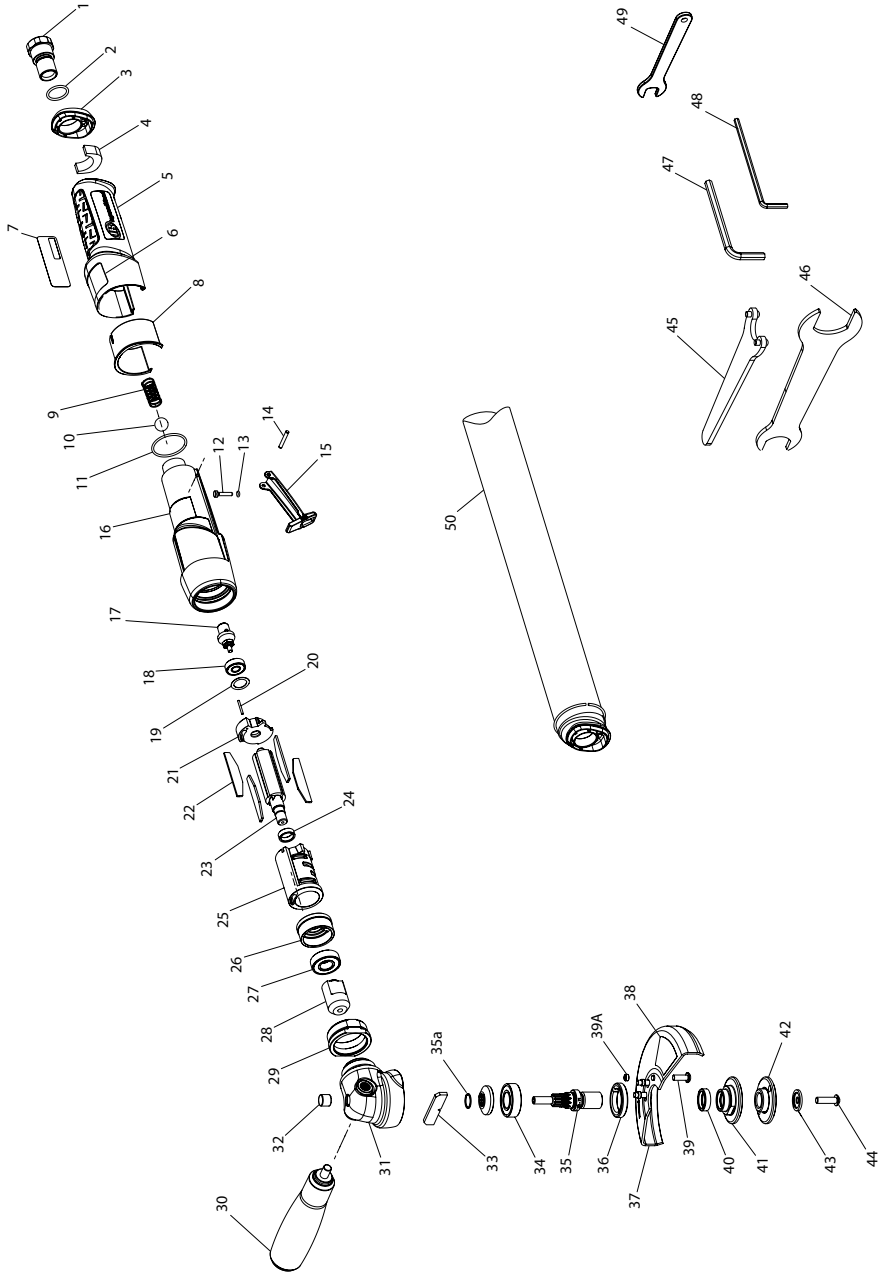

(Dwg. 45664240)



45654530
Edition 3
February 2010

3445MAX and 345MAX Series Air Grinder - Parts List

Item	Part Description	Part Number	Item	Part Description	Part Number
1	Inlet Bushing Assembly	MG1-A465	29	Clamp Nut	MG1-27
*	Inlet Bushing	---	30	Handle	MG1-48
*	Inlet Screen	R1602-61	31	Angle Housing Assembly	MG1-A550
2	Inlet Seal	45635141		Angle Housing	---
3	Rear Exhaust Diffuser	MG1-123	32	Needle Bearing	MG1-693
4	Rear Exhaust Diffuser Muffler	MG1-311	*	Grease Fitting	D0F9-879
5	Housing Sleeve Assembly	MG1-A747	33	Wick	LA2-561
6	Warning Label	MG1-99	34	Arbor Bearing	MG1-593
7	Model Label		35	Arbor	
	For 3445MAX	3445MAX-300		For 3445MAX and 345MAX	MG1-4
	For 345MAX	345MAX-300		For 3445MAX-M and 345MAX-M	MG1-4M
	For 3445MAX-M	3445MAX-M-300	35a	Retaining Ring	45669389
	For 345MAX-M	345MAX-M-300	36	Bearing Retainer	MG1-531
8	Housing Sleeve Trim	MG1-747T1	37	Wheel Guard Assembly	
9	Ball Valve Spring	MG1-51		For 3445MAX and 3445MAX-M	MG1-A106-45
10	Ball	D10-280		For 345MAX and 345MAX-M	MG1-A106-5
11	Motor Housing O-Ring	45631025		Wheel Guard	---
12	Throttle Pin	MG1-161	38	Guard Warning Label	MG1-99G
13	Throttle Pin O-Ring	45635125	39	Guard Mounting Screw (3)	16610875
14	Lever Pin	RG1-120	39A	Guard Screw Retaining Grommet (3)	MG1-86
15	Lever Assembly	RG1-A400	40	Wheel Spacer (For use with thread on wheels)	MG1-339
	Lever	---	41	Wheel Flange	
	Lock Spring	---		For 3445MAX and 345MAX	MG1-337
	Lock Pin	---		For 3445MAX-M and 345MAX-M	MG1-337M
	Lever Lock	---	42	Flange Nut	
16	Motor Housing Assembly	MG1-A40		For 3445MAX and 345MAX	MG1-338
	Motor Housing	---		For 3445MAX-M and 345MAX-M	MG1-338M
*	Throttle Bushing	---	43	Wheel Retaining Screw Washer	LG2-218
*	Ball Valve Seat	---	44	Wheel Retaining Screw	LG2-219M
17	Controller Assembly	MG1-A424	45	Flange Nut Wrench	AG3-26M
18	Rear Rotor Bearing	MG1-127	46	Clamp Nut and Wheel Flange Wrench	MG1-253
19	Wave Spring	GS25-250	47	Arbor Wrench	AG230-340M
20	Roll Pin	45626959	48	Wheel Retaining Screw Wrench	AG2-562
21	Rear End Plate	MG1-12	49	Controller Wrench	112915
22	Vane Pack (4)	MG1-42-4	50	Piped Away Exhaust Assembly	MG1-K284
23	Rotor	MG1-53-4		Piped Away Exhaust Adapter	---
24	Motor Spacer	MG1-65		Piped Away Exhaust Hose	---
25	Cylinder	MG1-3		Exhaust Hose Retaining Ring	---
26	Front End Plate	MG1-11		Piped Away Exhaust Inlet Bushing Assembly	---
27	Front Rotor Bearing	MG1-24			
28	Bevel Pinion and Bevel Gear Set	LA2-A552-1.3			

* Not Shown

Parts and Maintenance

When the life of the tool has expired, it is recommended that the tool be disassembled, degreased and parts be separated by material so that they can be recycled.

Tool repair and maintenance should only be carried out by an authorized Service Center.

Refer all communications to the nearest **Ingersoll Rand** Office or Distributor.

Related Documentation

For additional information refer to:

Air Grinder Product Safety Information Manual 04584959.

Air Grinder Product Information Manual 45654522.



www.ingersollrandproducts.com
© 2010 Ingersoll Rand Company

45654530
Edition 3
February 2010