

# 131S-EA and 131S-2-EA Air Impact Wrench Exploded View

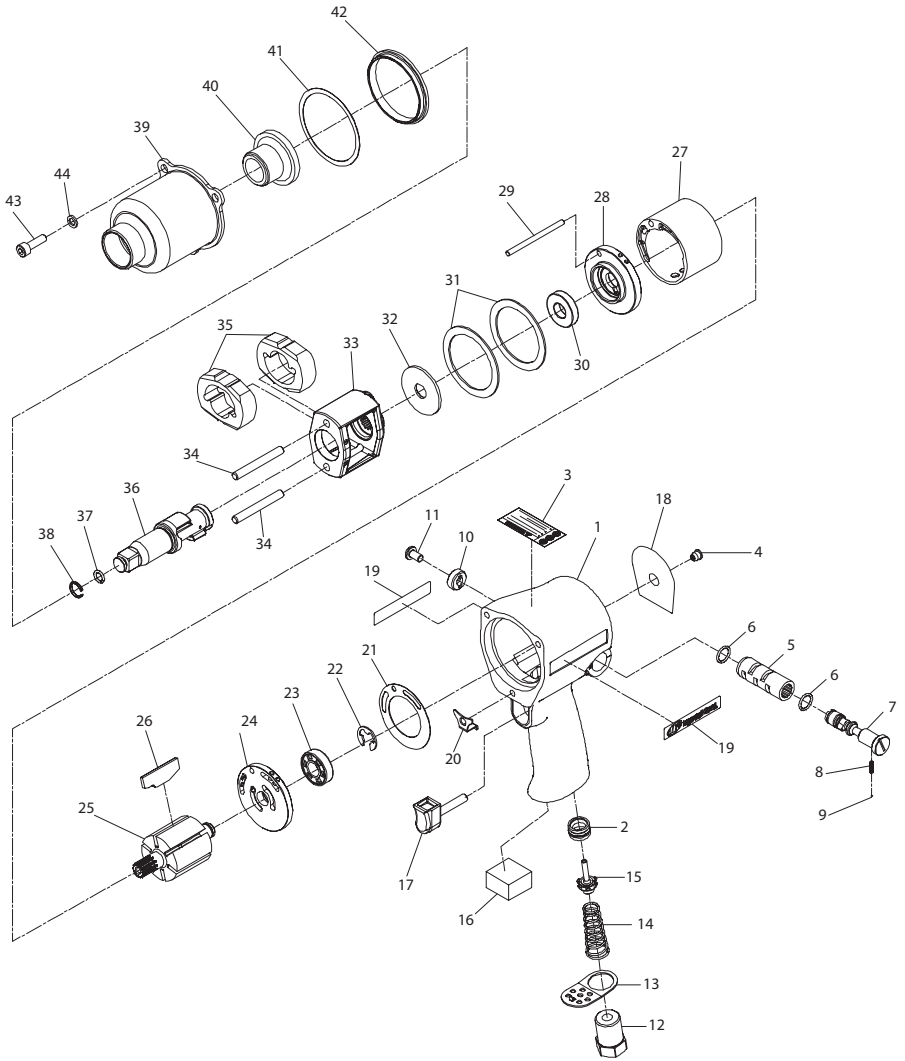

(Dwg. TPA1783)

## 131S-EA and 131S-2-EA Air Impact Wrench Parts List

Item	Part Description	Part Number	Item	Part Description	Part Number
	Motor Housing Assembly	131S-A40	24	Rear Endplate	231-12
1	Motor Housing	----	25	Rotor	231-53
2	Throttle Valve Seat	131-303	26	Vane (set of 6 Vanes)	2131-42A-6
3	Warning Label	WARNING-2-99	27	Cylinder	131-3
4	Grease Fitting	131-188	28	Front Endplate	231-11
5	Reverse Valve Bushing	231-A330	29	Cylinder Dowel	230-98
6	Reverse Valve Bushing Seal (2)	PS3-67	30	Front Rotor Bearing	4U-97
7	Reverse Valve	231-329A	31	Motor Clamp Washer (2)	227-207
8	Reverse Valve Detent Spring	131-664	32	Hammer Frame Rear Washer	231-706
9	Reverse Valve Detent Ball	AV1-255	33	Hammer Frame Assembly	231XP-A703
10	Reverse Valve Knob	131-666	34	Hammer Pin (2)	231-704
11	Reverse Valve Knob Screw	231-665	32	Hammer (2)	231XP-724
12	Inlet Bushing	131-565	36	Anvil Assembly	
13	Exhaust Deflector	235-EU-23		for 131S-EA	231B-A626
14	Throttle Valve Spring	131-51		for 131S-2-EA (2" extended)	231B-A414
15	Throttle Valve	131-50	37	Socket Retainer O-Ring	R1A-159
16	Exhaust Silencer	235-311	38	Socket Retaining Ring	231-425A
17	Trigger Assembly	231H-A93	39	Hammer Case Assembly	131-A927
18	Nameplate	131-301	40	Hammer Case Bushing	705-941
19	Label (2)	131-300	41	Hammer Case Gasket	230-36
20	Trigger Retainer	131-656	42	Hammer Case Pilot	405-800
21	Endplate Gasket	231-283	43	Hammer Case Cap Screw (3)	131-638
22	Rear Rotor Bearing Retainer	131-118	44	Hammer Case Cap Screw Lock Washer (3)	131-637
23	Rear Rotor Bearing	402-22	*	Reverse Valve Kit (includes 7,8,9,10,11)	231-329A-TK

\* Not Shown

### Parts and Maintenance

When the life of the tool has expired, it is recommended that the tool be disassembled, degreased and parts be separated by material so that they can be recycled.

Tool repair and maintenance should only be carried out by an authorized Service Center.

Refer all communications to the nearest **Ingersoll Rand** Office or Distributor.

### Related Documentation

For additional information refer to:

Air Impact Wrench Product Safety Information Manual 04580916.

Air Impact Wrench Product Information Manual 04584751.

Manuals can be downloaded from [www.ingersollrandproducts.com](http://www.ingersollrandproducts.com)

