

Automotive & Maintenance Tools

2014





For more than 100 years, professionals have relied on Ingersoll Rand Power Tools for quality and performance on the toughest jobs. Our advanced engineering and manufacturing have a standard of excellence often copied, but never matched. When it comes to assembly tools, industrial tools, cordless tools and vehicle service tools, don't settle for less. Count on genuine Ingersoll Rand power tools, accessories, and equipment.



Services Tools

- Complete line of Impacttools™, ratchets, drills/drivers and surface preparation tools to meet all needs
- Complete offering of professional-grade cordless tools and kits for use in a variety of applications including garages and the Vehicle Service industry



Engine Starters & Air Motors

- Leading air motors solutions for the marine, oil and gas, power generation, mining and rail industries
- Full line of Vane Starters, Turbine Starters, Engine Barring Motors, Geared Motors, Direct Drive Motors, Piston Motors



Industrial Tools

- Wide range of Impacttools™, surface finishing and construction tools for product and maintenance applications
- Ergonomically designed for increased productivity and safety
- Most advanced tools of their type in the world for the size, weight and power output



Tool Parts & Accessories

- **Air Line Accessories** – products for air treatment and transport including filters, regulators, lubricators, hoses, couplers and plugs
- **Consumables and Attachments** – durable and reliable consumables and attachments such as impact sockets, tool steels, abrasives and pads, reciprocating saw blades and drill and nutrunner bits to meet all needs
- **Ergonomic Accessories** – products specifically designed to help you perform your job more efficiently and safely, such as spring balancers, torque reaction arm grips and braces
- **Maintenance Accessories** – lubricants and grease guns help maximize performance by keeping your tools up and running
- **Tune-up Kits** – genuine Ingersoll Rand parts provide durability and keep tools running at peak performance



Assembly Tools

- Air and electric screwdrivers, nut runners, drills and accessories for all types of assembly
- Products deliver the best torque accuracy in the industry, with award-winning ergonomic design
- Full range of torque verification and calibration equipment to ensure accurate performance



Precision Fastening

- Precision air and electric assembly equipment and fastening control systems for consistent and precise tool performance
- Superior user-oriented ergonomics and process control for reliability
- Custom configurations and engineering available to meet unique needs



The National Association for Stock Car Auto Racing (NASCAR) is the largest stock car racing in US, which governs multiple auto racing sports events. Ingersoll Rand has a long history with this famous race. We has been active in three big racing series -- NASCAR Nationwide Series, NASCAR Camping World Truck Series and Sprint Cup Series as a sponsor or partner since 2012.

Ingersoll Rand's specialty racing tools have been a familiar sight in NASCAR garages from the beginning. NASCAR pit stops were revolutionized in 1960 with the introduction of the "Ingersoll Rand 405" and then again in 1972 when the company added the "twin hammer" impact mechanism. Our tools help crew make repairs faster and that is all what a race team strives for. Today, nearly every pit crew on the NASCAR circuit relies on the Ingersoll Rand ThunderGun(tm) for quick tire changes. Practically every NASCAR team uses Ingersoll Rand Impacttools(tm) or impact wrenches in the pits while they're performing pit changeovers in winning times.

Ingersoll Rand has earned the confidence of racing teams across a long and illustrious history and will continue working with drivers, mechanics, engineers and pit crew members in this season.



-  Voltage
-  Working torque range
-  Maximum torque
-  Blows per minute
-  Maximum free speed
-  Tool weight
-  Tool length
-  Tool height
-  Average air consumption
-  Max. air consumption
-  Maximum air flow
-  Air inlet diameter
-  Minimum hose diameter
-  Sound pressure
-  Rated power
-  Vibration level
-  Piston stroke
-  Collet capacity
-  Shank diameter
-  Disc / pad diameter
-  Maximum chuck capacity
-  Spindle thread

150

Best sellers for Service & Maintenance



AIR TOOLS

Air Ratchets.....	5
1/4" and 3/8" Air Impacttools™	6
1/2" Air Impacttools™.....	7 - 8
3/4" Air Impacttools™.....	9
1" Air Impacttools™ / Pistol Handle.....	10
1" Air Impacttools™ / Rear Handle	11
Air Drills	12
Air Tyre Buffers.....	12
Air Screwdrivers.....	13
Air Caulking Guns.....	13
Air Riveters.....	13
Air Hammers & Scalers.....	14
Air Die Grinders & Cutting Tools	15
Air Die Grinder Kits.....	16
Air Wheel Grinders and Cutting Tools	17
Air Sanders & Polishers	18 - 20
Air Filters, Regulators & Lubricators	21
Quick Release Couplings & Nipples	22
Air Hoses.....	23
Lubricants	23

Air Ratchets

1099XPA - 1/2"
109XPA - 3/8"

- 103 Nm (76 ft-lb).
- 220 rpm.
- Variable speed lever.
- 360° adjustable exhaust.

Accessories: **109-BOOT**
 (CPN: 45505336),
 protective tool boot.

1077XPA-AP - 1/2"
107XPA - 3/8"

- 73 Nm (54 ft-lb).
- 160 rpm.
- Variable speed lever.
- 360° adjustable exhaust.

Accessories: **107-BOOT**
 (CPN: 45505328),
 protective tool boot.

1770 - 1/2"
170 - 3/8"

- 81 Nm (60 ft-lb).
- 160 rpm.
- Variable speed lever.



NEW

1207MAX-D4 - 1/2"
1207MAX-D3 - 3/8"

- 88 Nm (65 ft-lb) and 200 rpm.
- Composite housing.
- Power regulator.
- Variable speed lever.
- 360° adjustable exhaust.



NEW

1105MAX-D3 - 3/8"
1105MAX-D2 - 1/4"

- 41 Nm (30 ft-lb) and 300 rpm.
- Only 0.65 kg and 187 mm.
- Composite housing.
- Power regulator.
- Variable speed lever.

Accessories: **103-BOOT** (45505310),
 protective tool boot.



NEW

***105-C3 & 105-D3 - 3/8"**
***105-D2 - 1/4"**

- 34 Nm (25 ft-lb).
- 250 rpm.
- Only 0.64 kg and 186 mm.
- Variable speed lever.

Accessories: **103-BOOT** (45505310),
 protective tool boot.
 *105-C3-different gear holder & rotor to
 105-D3



Impact Socket Sets

SK2M12 (CPN: 81287336): 1/4" socket set (6, 7, 8, 9, 10, 11, 12, 13 and 14 mm, 50 and 100 mm extensions, 3/8" F x 1/4" M adapter).

SK3M10 (CPN: 81287344): 3/8" socket set (9, 10, 11, 12, 13, 14, 15, 16, 17 and 19 mm).

SK4M14 (CPN: 81287351): 1/2" socket set (10, 11, 12, 13, 14, 15, 16, 17, 18, 19, 21, 22, 23 and 24 mm).



SK2M12



SK3M10



SK4M14

Specifications at 6.2 bar (90 psi)

1/2" ■											
1099XPA	14-87	103	220	1.51	306	1/4"	10	1.9	11.3	92.4	2.5 / 0.7
1207MAX-D4	14-81	88	200	1.45	275	1/4"	10	1.9	10.8	85.0	3.2 / 1.1
1077XPA-AP	14-61	73	160	1.25	276	1/4"	10	1.9	8.8	94.4	< 2.5
1770	14-81	81	160	1.17	262	1/4"	10	1.9	10.0	94.8	2.8 / 0.7
3/8" ■											
109XPA	14-87	103	220	1.50	306	1/4"	10	1.9	11.3	92.4	2.5 / 0.7
1207MAX-D3	14-81	88	200	1.45	275	1/4"	10	1.9	10.8	85.0	3.2 / 1.1
107XPA	14-61	73	160	1.24	276	1/4"	10	1.9	8.8	94.4	< 2.5
170	14-81	81	160	1.16	262	1/4"	10	1.9	10.0	94.8	2.8 / 0.7
1105MAX-D3	7-34	41	300	0.65	187	1/4"	10	1.6	9.4	88.9	5.7 / 1.0
105-C3/105-D3	7-27	34	220	0.64	186	1/4"	10	1.4	8.5	81.8	5.1 / 0.9
1/4" ■											
1105MAX-D2	7-34	41	300	0.65	187	1/4"	10	1.6	9.4	88.9	5.7 / 1.0
105-D2	7-27	34	220	0.64	186	1/4"	10	1.4	8.5	81.8	5.1 / 0.9
105-L2**	7-27	34	220	0.71	214	1/4"	10	1.4	8.5	81.8	5.1 / 0.9

(1) ISO28927 – 3-axis measurement: vibration level / measurement uncertainty. (2) Anvil is ball-pin type. ** Extended head

1/4" and 3/8" Air Impacttools™

- 2115PTiMAX-AP - 3/8" pin type
- 2115TiMAX-AP - 3/8" ring type
- 2115QTiMAX - 3/8" ring type (Quiet)



Ball and Cam Jumbo Hammer Twin Hammer Pinless Single Swinging Hammer Single Swinging Hammer Double Swinging Hammer Pin Clutch



Pin type



Ring type
(all models except 2115PTiMAX-AP)

- 407 Nm (300 ft-lb).
- Only 1.13 kg and 151 mm.
- Twin-hammer impact mechanism.
- Titanium hammer case and composite housing.
- 4-position power regulator.
- 1-hand forward and reverse switch.



212A - 3/8"

- 244 Nm (180 ft-lb).
- Only 1.31 kg.
- Jumbo-hammer impact mechanism.
- 5-position power regulator.



Accessories: **212-BOOT**
(CPN: 45505344), protective tool boot.

Accessories: **2115-BOOT**
(CPN: 45505351), protective tool boot.

2115Qi (Quiet) - 3/8"

- 370 Nm (273 ft-lb).
- Only 1.13 kg and 151 mm.
- Twin-hammer impact mechanism.
- Aluminum hammer case and composite housing.
- 4-position power regulator.
- 1-hand forward and reverse switch.



211 - 3/8"

- 204 Nm (150 ft-lb).
- Only 1.09 kg.
- Jumbo-hammer impact mechanism.
- 5-position power regulator.



LA158 - 3/8"

- 136 Nm (100 ft-lb).
- Only 1.25 kg and 137 mm.
- Single swinging-Hammer impact mechanism.
- Power regulator.



2102XP - 3/8"

2101XP - 1/4"

- 68 Nm (50 ft-lb).
- Only 0.6 kg and 165 mm.
- Double Swinging-hammer impact mechanism.
- Composite housing.
- 1-hand forward and reverse switch.

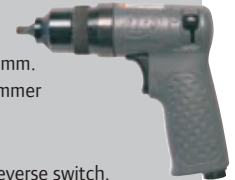

NEW

216B - 3/8"

- 271 Nm (200 ft-lb).
- Only 1.27 kg.
- Pin clutch impact mechanism.
- Power regulator.



NEW

NEW

2015MAX - 3/8"

- 244 Nm (180 ft-lb).
- Only 1.54 kg.
- Jumbo-hammer impact mechanism.
- Composite housing.
- 2-position power regulator.

The power of an impact with the reach of a ratchet!

Service Kits



	A	B
2115PTiMAX	2115-TK2	2115-THK2
2115QTiMAX	2115-TK2	2115-THK2
2115XP	2115-TK2	2115-THK2
2015MAX	2015-TK	2015-THK
212	212-TK2	—
211	211-TK2	—
LA158	LA158-RK2	LA158-RK1

Specifications at 6.2 bar (90 psi)

	Nm	Max. Nm	1 min. rpm	1 min.	kg	mm	NPTF	mm	L/s	Max L/s	dB(A)	m/s ² / K ⁽¹⁾
3/8" <input type="checkbox"/>												
2115PTiMAX-AP	34-312	407*	15 000	1 500	1.13	151	1/4"	10	1.9	8.0	93.2	7.5 / 1.8
2115QTiMAX	34-312	407*	15 000	1 500	1.13	151	1/4"	10	1.9	8.0	93.2	7.5 / 1.8
2115Qi	34-285	370*	15 000	1 500	1.13	151	1/4"	10	1.9	8.0	94.0	7.5 / 1.8
216B	20-217	271	8 500	1 600	1.27	196	1/4"	10	1.4	9.0	90.0	5.2 / 1.0
2015MAX	61-190	244*	7 100	2 100	1.54	332	1/4"	10	1.6	9.0	96.6	17.4 / 3.0
212A/(222A-1/2" <input type="checkbox"/>)	27-170	244	10 000	1 500	1.31	152	1/4"	10	1.2	5.2	97.5	6.5 / 1.0
211	27-170	204	10 000	1 500	1.09	168	1/4"	10	1.2	5.2	104.0	5.9 / 1.6
LA158	7-100	136	10 000	1 400	1.25	137	1/4"	10	1.9	7.5	88.4	3.3 / 1.1
2102XP	34-54	68	11 000	1 250	0.63	165	1/4"	10	0.8	8.6	85.8	4.4 / 0.8
1/4" <input type="checkbox"/>												
2101XP**	34-54	68	11 000	1 250	0.63	165	1/4"	10	0.8	8.6	85.8	4.4 / 0.8

(1) ISO28927 – 3-axis measurement: vibration level / measurement uncertainty. * Reverse bias

** 2101K-1/4" impact tool kit c/w 10-piece 1/4" SAE & metric sockets & 2101XP in a blow-molded plastic case

1/2" Air Impacttools™

2135PTiMAX-AP - Pin-type anvil

2135QPTiMAX-AP (Quiet) - Pin-type anvil

2135TiMAX-AP/2135QTiMAX-AP (Quiet)

- Ring-type anvil

2135Ti-2MAX-AP/2135QTi-2MAX-AP (Quiet)

- 50 mm anvil / ring



Pin type



Ring type

- 1 057 Nm (780 ft-lb).
- Only 1.84 kg.
- Twin-hammer impact mechanism.
- Titanium hammer case and composite housing.
- 1-hand forward and reverse switch.
- 4-position power regulator.

Accessories: **2135-BOOT** (CPN: 45505377), protective tool boot.

2125PTiMAX-AP - Pin-type anvil

2125TiMAX-AP/2125QTiMAX-AP (Quiet)

- Ring-type anvil

- 450 Nm (332 ft-lb).
- Only 1.14 kg and 155 mm.
- Twin-hammer impact mechanism.
- Titanium hammer case and composite housing.
- 1-hand forward and reverse switch.
- 4-position power regulator.

Accessories: **2115-BOOT** (CPN: 45505351), protective tool boot.

2135Qi - Ring-type anvil (Quiet)

- 935 Nm (690 ft-lb).
- Only 1.9 kg.
- Twin-hammer impact mechanism.
- Aluminum hammer case and composite housing.
- 1-hand forward and reverse switch.
- 4-position power regulator.

Accessories: **2135-BOOT** (CPN: 45505377), protective tool boot.

2125Qi - Ring-type anvil (Quiet)

- 410 Nm (302 ft-lb).
- Only 1.14 kg and 155 mm.
- Twin-hammer impact mechanism.
- Aluminum hammer case and composite housing.
- 1-hand forward and reverse switch.
- 4-position power regulator.

Accessories: **2115-BOOT** (CPN: 45505351), protective tool boot.

231GXP - Ring-type anvil

- 610 Nm (450 ft-lb).
- Twin-hammer impact mechanism.
- Steel hammer case.
- 5-position power regulator.

Accessories: **231-BOOT** (CPN: 45505427), protective tool boot.

236 - Ring-type anvil

- 610 Nm (450 ft-lb).
- Half jumbo-hammer impact mechanism.
- Steel hammer case.
- 2-position power regulator.

Accessories: **236-BOOT** (CPN: 45528148), protective tool boot.



2135QPTiMAX-AP

2135QTi-2MAX-AP



2125QTi-MAX-AP



2135Qi



2125Qi



231GXP



236

NEW



2130AP

2130XP-TL

2130AP - Ring-type anvil

2130AP-2-50mm anvil

2130XP-TL

Ring-type anvil / Torque limited

- 816 Nm (602 ft-lb).
- Forward torque limited (2130XP-TL): 47-75 Nm (35-55 ft-lb).
- Only 1.9 kg.
- Twin-hammer impact mechanism.
- Aluminum hammer case and composite housing.

Accessories: **2130-BOOT** (CPN: 45505369), protective tool boot.

NEW



The power of an impact with the reach of a ratchet!

2025MAX

- 244 Nm (180 ft-lb).
- Only 1.54 kg.
- Jumbo-hammer impact mechanism.
- Composite housing.
- 2-position power regulator.

1/2" Air Impacttools™

231C-AP-Ring-type anvil

- Introduced over 25 years ago
 - Most popular in the world
 - Twin-hammer impact mechanism
 - 813 Nm(600 ft-lb), reverse bias
 - Steel hammer case
 - 5-position power regulator
- Accessories: 231-BOOT, Protective tool boot.



231HA-Ring-type anvil 231HA-2-50mm anvil/ring

- 800Nm (590ft-lb), reverse bias
 - Handle exhaust
 - Twin-hammer impact mechanism
- Accessories: 231-BOOT, Protective tool boot



E131-Ring-type anvil

- 678Nm(500ft-lb), reverse bias
- Front exhaust
- Twin-hammer impact mechanism
- Efficient performance at Economical price



244A-Ring-type anvil 244A-2-50mm anvil/ring

- 678 Nm (500ft-lb), non-biased
 - Front exhaust
 - Twin-Hammer impact Mechanism
- Accessories:244-BOOT, Protective tool boot



232TGSL-Ring-type anvil

- 10,000 rpm,fastest 1/2" impact tool
 - 847Nm(625ft-lb), reverse bias
 - Twin-Hammer impact mechanism
- Protective tool boot 232TGSL-P32 comes standard



131S-EA-Ring-type anvil

- 610Nm(450 ft-lb), reverse bias
- Handle exhaust
- Twin-Hammer impact mechanism
- 5-position power regulator



Specifications at 6.2 bar (90 psi)

	Nm	Max. Nm	1 min. rpm	1 min.	kg	mm	Air NPTF	Air mm	L/s	Max L/s	dB(A)	m/s ² / K(0)
1/2" ■												
2135QPTiMAX-AP	68-746*	1 057	9 800	1 250	1.84	187	1/4"	10	2.4	11.3	94.2	13.3 / 4.6
2135QTiMAX-AP	68-746*	1 057	9 800	1 250	1.84	187	1/4"	10	2.4	11.3	94.2	13.3 / 4.6
2135QTi-2MAX-AP	68-746*	1 057	9 800	1 250	2.05	241	1/4"	10	2.4	11.3	94.2	9.7 / 1.8
2135Qi	68-680*	935	8 900	1 250	1.90	187	1/4"	10	2.4	11.3	95.5	13.3 / 4.6
2130AP	34-474*	816	9 500	1 200	1.90	187	1/4"	10	2.1	10.4	94.3	8.9 / 2.0
2130XP-TL	47-75 ⁽²⁾	816	7 800	1 150	1.90	187	1/4"	10	2.1	14.2	94.4	10.0 / 1.5
231GXP	34-407*	610	8 000	1 200	2.63	185	1/4"	10	2.0	10.3	91.5	6.3 / 2.1
236	34-271	610	7 400	1 200	2.40	180	1/4"	10	2.0	11.3	90.3	12.0 / 1.0
2125PTiMAX-AP	34-340*	450	15 000	1 500	1.14	155	1/4"	10	1.9	8.0	93.2	7.5 / 1.8
2125QTiMAX-AP	34-340*	450	15 000	1 500	1.14	155	1/4"	10	1.9	8.0	93.2	7.5 / 1.8
2125Qi	34-310*	410	15 000	1 500	1.14	155	1/4"	10	1.9	8.0	94.0	7.5 / 1.8
2025MAX	61-190*	244	7 100	2 100	1.54	332	1/4"	10	1.7	9.0	96.6	17.4 / 3.0
231C-AP	34-475	813*	8,000	1,200	2.63	185	1/4"	10	2	10.4	99	6.5/0.8
244A	54-475	678	7,000	1,300	2.72	185	1/4"	10	2.6	10	93	8.7/0.8
231HA	34-475	800*	8,000	1,150	2.63	185	1/4"	10	2	10.4	94	6.5/0.8
232TGSL	54-544	847*	10,000	1,200	2.72	185	1/4"	10	2.6	10.9	105	
E131	34-475	678*	8,750	1,175	2.6	192	1/4"	10	2	13.6	98	7.8/2.4
2135Ti-2MAX-AP	68-746	1054	9,800	1,250	1.99	241	1/4"	10	2.4	11.3	99.8	9.7/1.8
2135TiMAX-AP	68-746	1054	9,800	1,250	1.79	187	1/4"	10	2.4	11.3	99.8	13.3/4.6
2135PTiMAX-AP	68-746	1054	9,800	1,250	1.79	187	1/4"	10	2.4	11.3	99.8	13.3/4.6
131S-EA	34-475	610	8,000	1,225	2.63	185	1/4"	10	2		90.7	5.2

(1) ISO28927 – 3-axis measurement: vibration level / measurement uncertainty — (2) Torque-limited.

*Reverse bias

Service Kits



	A	B
2135QPTiMAX-AP	2135-TK2	2135PTi-THK1
2135TiMAX-AP/ 2135QTiMAX-AP	2135-TK2	2135-THK1
2135QTi-2MAX-AP	2135-TK2	2135-2-THK1
2135Qi	2135-TK2	2135-THK1
2130AP	2130-TK1	2130-IMK1
2130XP-TL	2130-TK1	2130XPTL-IMK1
231GXP	231XP-TK1	231XP-THK1
236	236-TK1	—
2125PTiMAX	2115-TK2	2115-THK2
2125QPiMAX	2115-TK2	2115-THK2
2125XP	2115-TK2	2115-THK2
2025MAX	2015-TK	2015-THK
231C-AP	231-TK2/3	231C-THK1
244A/244A-2	244-TK2	231B-THK1/231B-THK2
231HA/231HA-2	231HP-TK1	231B-THK1/231B-THK2

Impact Socket Sets

SK4M18 (CPN: 81287385): 1/2" socket set. Contains 9 standard sockets (10, 11, 13, 14, 17, 19, 21, 22 and 24 mm), 4 deep sockets (13, 14, 21, and 24 mm), 3 deep / thin wall sockets (17, 19 and 21 mm), 125 mm extension bar and 1/2" square drive power joint.

SK4M14 (CPN: 81287351): 1/2" socket set (10, 11, 12, 13, 14, 15, 16, 17, 18, 19, 21, 22, 23 and 24 mm).

SK4M5L (CPN: 81287369): 1/2" socket set. Contains 5 deep sockets (17, 19, 21, 22 and 24 mm)

SK4M3L (CPN: 81287377): 1/2" socket set. Contains 3 deep insulated, thin wall sockets (17, 19 and 21 mm).



SK4M18



SK4M3L



SK4M14



SK4M5L

3/4" Air Impacttools™

NEW



- 2145QiMAX-AP - Short anvil**
- 2145QiMAX-3 - 75 mm anvil**
- 2145QiMAX-6 - 150 mm anvil**

- 1 830 Nm (1 350 ft-lb).
- Only 3.35 kg (2145QiMAX-AP).
- Twin-hammer impact mechanism.
- Steel hammer case and composite housing.
- 1-hand forward and reverse switch.
- 4-position power regulator.
- Ring & hole-through anvil.
- Accessories: **2145M-BOOT** (CPN: 48385033), protective tool boot.

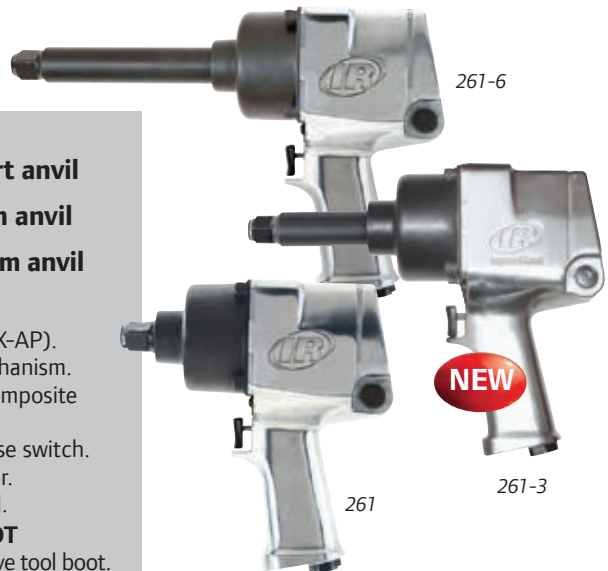

- 261 - Short anvil**
- 261-3 - 75 mm anvil**
- 261-6 - 150 mm anvil**

- 1 491 Nm (1 100 ft-lb).
- Jumbo-hammer impact mechanism.
- Steel hammer case.
- 5-position power regulator
- Ring type anvil.
- Accessories: **261-BOOT** (CPN: 45505468), protective tool boot.

- 2161XP - Short anvil**
- 2161XP-6 - 150 mm anvil**

- 1 695 Nm (1 250 ft-lb).
- Only 5.4 kg (2161XP).
- Twin-hammer impact mechanism.
- Steel hammer case.
- 3-position power regulator.
- Ring type anvil.

Accessories: **2161-BOOT** (CPN: 45505401), protective tool boot.



- 259 - Short anvil**

- 1 424 Nm (1 050 ft-lb).
- Only 4.0 kg and 218 mm.
- Pinless single swinging-hammer impact mechanism.
- 2-position power regulator.
- Ring type anvil.

Accessories: **259-BOOT** (CPN: 45661899), protective tool boot.



Service Kits



	A	B
2145QiMAX	2145-TK2	2145-THK2
2145QiMAX-3	2145-TK2	2145-THK2
2145QiMAX-6	2145-TK2	2145-THK2
2161XP	2161-TK2	-
2161XP-6	2161-TK2	-
261	261-TK2	216-THK1
261-3	261-TK2	-
261-6	261-TK2	-
259	259-TK1	259-THK1

SK6M6L (CPN: 81287401)

3/4" socket set. Contains 6 extended sockets (24, 27, 30, 32, 33 and 36 mm).

Specifications at 6.2 bar (90 psi)

	Nm	Max Nm	1 min. rpm	1 min.	kg	L	NPTF	AIR	L/s	Max L/s	dB(A)	m/s ² / K(1)
3/4" ■												
2145QiMAX-AP	271-1 220	1 830*	6 300	1 150	3.35	217	3/8"	13	4.0	15.1	96.3	8.7 / 2.7
2145QiMAX-3	271-1 220	1 830*	6 300	1 150	3.79	293	3/8"	13	4.0	15.1	96.3	8.1 / 1.2
2145QiMAX-6	271-1 220	1 830*	6 300	1 150	4.23	369	3/8"	13	4.0	15.1	96.3	8.1 / 1.2
2161XP	407-1 356	1 695	6 000	1 025	5.35	216	3/8"	13	4.7	21.5	94.7	9.8 / 1.8
2161XP-6	407-1 356	1 695	6 000	1 025	5.94	370	3/8"	13	4.7	21.5	94.7	9.8 / 1.8
261	271-813	1 491	5 500	1 000	5.62	224	3/8"	13	4.5	17.9	98.1	10.4 / 1.3
261-3	271-813	1 491	5 500	1 000	5.90	300	3/8"	13	4.5	17.9	98.1	10.4 / 1.3
261-6	271-813	1 491	5 500	1 000	6.21	376	3/8"	13	4.5	17.9	98.1	10.4 / 1.3
259	271-1 085	1 424	6 500	1 000	4.00	218	3/8"	10	3.8	14.2	91.6	6.4 / 0.8

(1) ISO28927 – 3-axis measurement: vibration level / measurement uncertainty. * Reverse bias

1" Air Impacttools™ / Pistol Handle

NEW



2155QiMAX

- 1 830 Nm (1 350 ft-lb).
- Only 3.36 kg.
- Twin-hammer impact mechanism.
- Steel hammer case and composite housing.
- 1-hand forward and reverse switch.
- 4-position power regulator.
- Ring & hole-through anvil.

Accessories: **2145M-BOOT** (CPN: 48385033), protective tool boot.

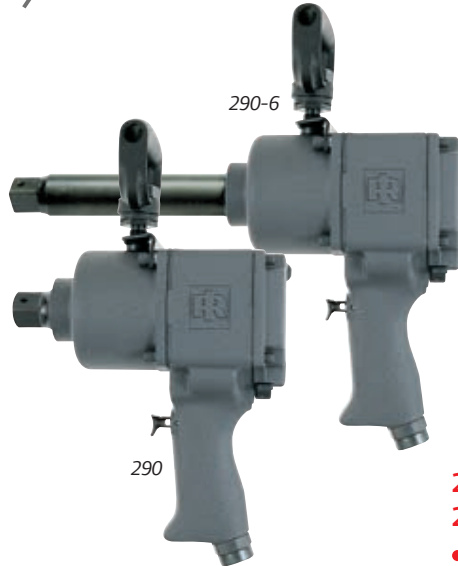

290 - Short anvil

290-6 - 150 mm anvil

- 2 169 Nm (1 600 ft-lb).
- Jumbo-hammer impact mechanism.
- Hole-through anvil.



295A - Short anvil

295A-6 - 150 mm anvil

- Designed for operation at 8.3 bar.
- 2 400 Nm (1 700 ft-lb) at 8.3 bar.
- Pinless single swinging-hammer impact mechanism.
- 3-position power regulator.
- Ring & hole-through anvil.

Accessories: **295-BOOT** (CPN: 45505484), protective tool boot.



2171XP - Short anvil (ring type)

2171XP-6 - 150 mm anvil (ring & hole-through)

- 1 695 Nm (1 100 ft-lb).
- Only 5.47 kg (2171XP).
- Twin-hammer impact mechanism.
- Steel hammer case.
- 3-position power regulator.

Accessories: **2161-BOOT** (CPN: 45505401), protective tool boot.

271

- 1 491 Nm (1 100 ft-lb).
- Jumbo-hammer impact mechanism.
- Steel hammer case.
- 5-position power regulator.
- Ring type anvil.

Accessories: **271-BOOT** (CPN: 45505468), protective tool boot.



Specifications at 6.2 bar (90 psi)

	Nm	Max. Nm	1 min. rpm	1 min.	kg	mm	NPTF	mm	L/s	Max L/s	dB(A)	m/s ² / K ⁽¹⁾
1" ■												
290	203-1 356	2 169	6 000	800	9.93	248	1/2"	19	4.7	28.3	104.6	22.7 / 2.6
290-6	203-1 356	2 169	6 000	800	10.75	388	1/2"	19	4.7	28.3	104.6	15.8 / 5.2
295A	136-1 220	2 400 ⁽²⁾	5 000	700	9.98	290	1/2"	13	4.7	17.5	97.0	8.6 / 1.0
295A-6	136-1 220	2 400 ⁽²⁾	5 000	700	11.4	449	1/2"	13	4.7	17.5	97.0	9.1 / 2.9
2155QiMAX	271-1 220	1 830*	6 300	1 150	3.36	225	3/8"	13	4.0	15.1	96.3	8.7 / 2.7
2171XP	407-1 356	1 695	6 000	1 025	5.47	226	3/8"	13	4.7	21.5	94.7	10.3 / 1.3
2171XP-6	407-1 356	1 695	6 000	1 025	6.76	360	3/8"	13	4.7	21.5	94.7	9.9 / 3.0
271	271-1 224	1 491	5 500	1 000	5.67	226	3/8"	13	4.5	17.9	98.1	13.2 / 1.1

(1) ISO28927 – 3-axis measurement: vibration level / measurement uncertainty — (2) at 8.3 bar (120 psi). * Reverse bias

Service Kits

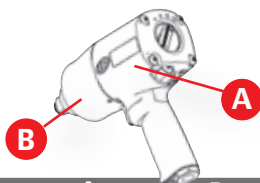

	A	B
290	290-TK2	-
290-6	290-TK2	-
295A	295A-TK1	-
295A-6	295A-TK1	-
2155QiMAX	2145-TK2	2145-THK2
2171XP	2161-TK2	2190-THK1
2171XP-6	2161-TK2	2190-6-THK1
271	261-TK2	-

Protective Tool Boots



1" Air Impacttools™ / Rear Handle

631S – standard anvil

631L – 200 mm anvil

- 4 300 Nm (3 170 ft-lb).
- Pinless single swinging-hammer impact mechanism.
- 4-position power regulator.
- Allen key & 1/2" air inlet connector.
- Hole-through anvil.



4300 Nm !

631LSK-packed with:

- 2 pcs 41mm hex socket (90mm long) &
- 2 pcs 21 mm female square budd wheel socket (60mm long)

2190Ti – Short anvil, ergonomic chainsaw-type handle

2190Ti-6 – 150 mm anvil, ergonomic chainsaw-type handle

2190DTi-6 – 150 mm anvil, rear handle

- 2 237 Nm (1 650 ft-lb).
- Only 6.13 kg (2190Ti).
- Twin-hammer impact mechanism.
- Titanium hammer case.
- 3-position power regulator.
- Ring & hole-through anvil.

Accessories: **2190-BOOT** (CPN: 45505419), protective tool boot.



E688-8 – 200mm anvil

- 3800Nm
- pinless single swinging-hammer impact mechanism
- Designed for vehicle service market

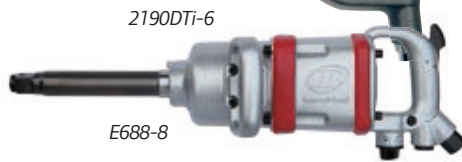

280 – Short anvil

280-6 – 150 mm anvil

280-S-6-#5 Spline Drive, 150mm anvil

- 2 169 Nm (1 600 ft-lb).
- Jumbo-hammer impact mechanism.
- Hole-through anvil.



285B-S6 – #5 Spline Drive, 150mm anvil

285B – Short anvil

285B-6 – 150 mm anvil, inside trigger, straight air inlet.

285B-6-AP – Outside trigger, 45 degree air inlet bushing

- Designed for operation at 8.3 bar.
- 2 400 Nm (1 700 ft-lb) at 8.3 bar.
- Pinless single swinging-hammer impact mechanism.
- 3-position power regulator.
- Ring & hole-through anvil.

Specifications at 6.2 bar (90 psi)

1" □	Nm	Max Nm	1 min. rpm	1 min.	kg	L	AIR	AIR	L/s	Max L/s	dB(A)	m/s ² / K(°)
	Nm	Nm	rpm	mm	mm	NPTF	mm	L/s	L/s			
631L	271-3 390	4 300	3 500	700	16.6	624	1/2"	13	7.1	26.4	108.4	12.7 / 2.5
2190Ti	204-1 356	2 237	6 800	875	6.13	393	1/2"	13	5.6	27.4	103.8	10.4 / 1.5
2190Ti-6	204-1 356	2 237	6 800	875	7.04	522	1/2"	13	5.6	27.4	103.8	12.7 / 2.9
2190DTi-6	204-1 356	2 237	6 800	875	7.26	475	1/2"	13	5.6	27.4	103.8	8.7 / 2.1
280	203-1 356	2 169	6 000	750	9.98	330	1/2"	13	4.7	26.0	109.1	24.1 / 3.4
280-6	203-1 356	2 169	6 000	750	10.8	470	1/2"	13	4.7	26.0	109.1	21.8 / 3.8
285B	136-1 220	2 400 ⁽²⁾	5 000	700	11.2	360	1/2"	13	4.7	17.5	99.8	8.0 / 1.2
285B-6	136-1 220	2 400 ⁽²⁾	5 000	700	12.6	519	1/2"	13	4.7	17.5	99.8	9.0 / 2.7
E688-8	271-3 500	3 800	4 600		16.5	630	1/2"	13	9.3	34	103.2	

(1) ISO28927 – 3-axis measurement: vibration level / measurement uncertainty — (2) at 8.3 bar (120 psi).

Service Kits



	A	B
631L	631L-TK1A	-
2190Ti	2190-TK1	2190-THK1
2190Ti-6	2190-TK1	2190-6-THK1
2190DTi-6	2190-TK1	2190-6-THK1
280-EU	280-TK2	-
280-6-EU	280-TK2	-
285B	285B-TK1	-
285B-6/285B-6-AP	285B-TK1	-



SK8M4L (CPN: 81287419): 1" socket set. Contains 4 extended sockets (27, 30, 32 and 33 mm).

Air Drills

NEW

7804XP

- 6.5 mm (1/4 in).
- 0.12 kW (0.17 HP).
- 1 600 rpm.
- Only 0.6 kg and 180 mm.
- Composite housing.
- Reversible.

7804K-Drill/Driver kit includes
7804XP & 22-Piece drill bit & drive set.



7807R

- 10 mm (3/8 in) standard chuck.
- 0.25 kW (0.33 HP) – 2 000 rpm.
- Reversible.



7803A - Standard chuck

7803AKC - Keyless chuck

7803RA - Standard chuck, reversible

7803RAKC - Keyless chuck, reversible

- 13 mm (1/2 in) chuck.
- 0.37 kW (0.50 HP) – 500 rpm.

Accessories: **7803-BOOT**
(CPN: 45524287), protective tool boot.

LA410-EU

- 10 mm (3/8 in) standard chuck.
- 0.25 kW (0.33 HP) – 4 500 rpm.

Accessories: **327LS-K284** (CPN: 10323095), piped-away exhaust system.

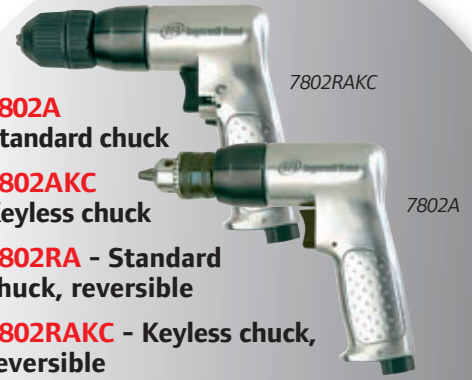

7802A Standard chuck

7802AKC Keyless chuck

7802RA - Standard chuck, reversible

7802RAKC - Keyless chuck, reversible

- 10 mm (3/8 in) chuck.
- 0.37 kW (0.50 HP) – 2 000 rpm.

Accessories: **7802-BOOT** (CPN: 45524279), protective tool boot.



LA410-EU

Specifications at 6.2 bar (90 psi)

	Max. Ø mm	Max. Nm	kW	1 min. rpm	kg	L mm	AIR NPTF	AIR mm	L/s	Max L/s	dB(A)	m/s ² / K ⁽¹⁾
Air Drills												
7803A	13	28	0.37	500	1.63	195	1/4"	10	1.9	12.7	83.0	<2.5
7803AKC	13	28	0.37	500	1.63	200	1/4"	10	1.9	12.7	83.0	<2.5
7803RA	13	28	0.37	500	1.64	195	1/4"	10	1.9	12.7	83.0	<2.5
7803RAKC	13	28	0.37	500	1.64	200	1/4"	10	1.9	12.7	83.0	<2.5
7802A	10	7	0.37	2 000	1.31	163	1/4"	10	1.9	12.3	83.0	2.8 / 0.7
7802AKC	10	7	0.37	2 000	1.35	175	1/4"	10	1.9	12.3	83.0	2.8 / 0.7
7802RA	10	7	0.37	2 000	1.30	163	1/4"	10	1.9	12.3	83.0	2.8 / 0.7
7802RAKC	10	7	0.37	2 000	1.36	175	1/4"	10	1.9	12.3	83.0	2.8 / 0.7
7807R	10	5	0.25	1 800	1.07	206	1/4"	10	1.9	8.1	89.2	<2.5
LA410-EU	10	2	0.25	4 500	0.91	228	1/4"	10	1.4	12.8	84.9	2.9 / 0.7
7804XP	6.5	3	0.12	1 600	0.80	180	1/4"	10	0.9	8.3	83.6	3.0 / 0.8

(1) ISO28927 – 3-axis measurement: vibration level / measurement uncertainty.

Air Tyre Buffers

327LS

- 0.38 kW (0.50 HP).
- 3 000 rpm.
- Only 0.50 kg.
- Piped-away exhaust system.



22 000 rpm



327

- Standard chuck: 10 mm (3/8 in).
- 0.38 kW (0.50 HP).
- Only 0.73 kg.

Accessories: **327LS-K284** (CPN: 10323095), piped-away exhaust system.

Specifications at 6.2 bar (90 psi)

	Ø mm	kW	1 min. rpm	kg	L mm	AIR NPTF	AIR mm	L/s	Max L/s	dB(A)	m/s ² / K ⁽¹⁾
Air Tyre Buffers											
327LS	7/16"Ø	0.38	3 000	0.50	216	1/4"	10	6.6	12.6	77.4 ⁽²⁾	<2.5
327	10 mm	0.38	22 000	0.73	224	1/4"	10	7.1	12.6	87.9	4.6 / 1.1

(1) ISO28927 – 3-axis measurement: vibration level / measurement uncertainty — (2) Piped-away exhaust system.

Air Screwdrivers – Specialty Air Tools

NEW

Double swinging hammer

2101XP-QC

- 68 Nm (50 ft-lb).
- 1 250 blows per minute.
- 11 000 rpm.
- Only 0.66 kg and 165 mm.
- Composite housing.
- 1-hand forward and reverse switch.



LA439-EU

- 13 Nm (9.6 ft-lb).
- 0.25 kW (0.33 HP).
- 1 800 rpm.
- Adjustable clutch.
- 1-hand forward and reverse switch.



LA412-EU

- 13 Nm (9.6 ft-lb).
- 0.25 kW (0.33 HP).
- 1 800 rpm.
- Positive jaw clutch.
- 1-hand forward and reverse switch.



371

- 13 Nm (9.6 ft-lb).
- 0.25 kW (0.33 HP).
- 1 800 rpm.
- Positive jaw clutch.
- 1-hand forward and reverse switch.



LA413-EU

- 13 Nm (9.6 ft-lb).
- 0.25 kW (0.33 HP).
- 1 800 rpm.
- Adjustable clutch.
- 1-hand forward and reverse switch.



Specifications at 6.2 bar (90 psi)

Air Screwdrivers	Max. Nm Nm	kW	1 min. rpm	1 min. blows/min	kg	mm	NPTF	mm	L/s	L/s	dB(A)	m/s ² / K ⁽¹⁾
2101XP-QC (impact)	68	—	11 000	1 250	0.66	165	1/4"	10	0.8	8.6	85.8	3.3 / 0.7
LA439-EU	13	0.25	1 800	—	1.60	216	1/4"	10	1.4	13.7	89.9	<2.5
LA412-EU	13	0.25	1 800	—	1.50	184	1/4"	10	1.9	13.7	89.6	<2.5
371	13	0.25	1 800	—	1.14	188	1/4"	10	1.9	10.2	91.0	<2.5
LA413-EU	13	0.25	1 800	—	1.10	260	1/4"	10	1.4	8.0	109.1	<2.5

(1) ISO28927 – 3-axis measurement: vibration level / measurement uncertainty.



LA428-EU

- Power regulator.
- Cartridge size: 50 x 215 mm (2 x 8.5 in).

LA415-EU

- Aluminum rivet capacity: 2.4 - 6.35 mm (3/32 - 1/4 in).
- Stroke: 16 mm (0.63 in).

LA437-EU

- Aluminum rivet capacity: 2.4 - 4.75 mm (3/32 - 3/16 in).
- Stroke: 16 mm (0.63 in).



LA415-EU

LA437-EU

94058 Blow Gun

(CPN: 25011222)

- Maximum operating pressure: 10.3 bar (150 psi).
- Flow 6.4 L/s.
- Air inlet diameter: 1/4" BSP.



Specifications at 6.2 bar (90 psi)

Air Caulking Gun	mm	mm	kg	mm	NPTF	mm	L/s	L/s	dB(A)	m/s ² / K ⁽¹⁾
LA428-EU	—	215	1.3	356	1/4"	10	—	< 70.0	< 2.5	
Air Riveters										
LA437-EU	2.4 - 4.75	16	2.8	164	1/4"	10	0.03 (2)	89.0	3.2 / 0.7	
LA415-EU	2.4 - 6.35	16	2.0	197	1/4"	10	0.03 (2)	86.8	< 2.5	

(1) ISO28927 – 3-axis measurement: vibration level / measurement uncertainty — (2) Per cycle.

Air Hammers & Scalers

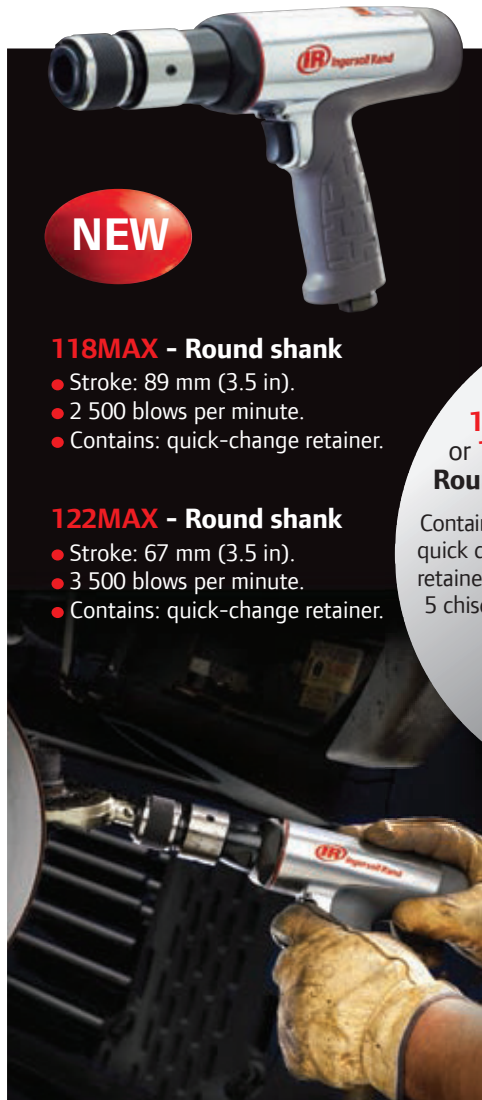

NEW

118MAX - Round shank

- Stroke: 89 mm (3.5 in).
- 2 500 blows per minute.
- Contains: quick-change retainer.

122MAX - Round shank

- Stroke: 67 mm (3.5 in).
- 3 500 blows per minute.
- Contains: quick-change retainer.

118MAXK or 122MAXK Round shank

Contains: hammer, quick change retainer and 5 chisels.



122MAXK



121/Q - Round shank

- Stroke: 58 mm (2.3 in).
- 3 000 blows per minute.



115-Round shank

- Stroke 41mm (1.63")
- 5,000 blows per minute

116-Round shank

- Stroke 67mm (2.6")
- 3,500 blows per minute
- Power regulator.

117-Round shank

- Stroke 89mm (3.5")
- 2,000 blows per minute.

*115K/116K/117K - includes 5 - piece chisels kit

121-K6 - Round shank

- Contains 121/Q and 6 chisels

121-K6



125

- Stroke: 28 mm (1.1 in)
- 4 600 blows per minute.
- Contains: NS11-122-19

125CI-Chisel Scaler

Accessories: sets of 19 needles

	Material	Length
NS11-122-19	Steel	178 mm
NS11-22-19	Steel	127 mm
NS11-522-19	Stainless steel	127 mm
NS11-B22-19	Beryllium copper	127 mm

Hammer Accessories

- 115-183 (CPN: 03788510): spring retainer for 115,116 & 117.
- AVC10-183 (CPN: 03010980): spring retainer for 121/Q.
- 9512 (CPN: 45563749): quick-change retainer for 121/Q,118MAX & 122MAX
- 9500 (CPN: 80117427): chisels, round shank (5 pieces).



115-183



9512



9500

Specifications at 6.2 bar (90 psi)

	1 min.	mm	mm	kg	mm	NPTF	mm	L/s	L/s	dB(A)	m/s ² / K ⁽¹⁾
Air Hammers - Round shank											
121/Q	3 000	10.2	58	1.59	194	1/4"	10	1.4	7.1	95.3	19.9 / 4.6
122MAX	3 500	10.2	67	1.80	218	1/4"	10	1.4	5.5	94.2	5.5 / 1.8
118MAX	2 500	10.2	89	2.10	314	1/4"	10	1.4	5.5	92.6	4.0 / 1.4
116	3 500	10.2	67	1.54	198	1/4"	10	1.4	7.1	101.4	14.8 / 2.2
Air Needle Scaler											
125	4 600	-	28.6	2.83	465	1/4"	8	3.8	7.1	96.6	8.3 / 1.3

(1) ISO28927 - 3-axis measurement: vibration level / measurement uncertainty.

Air Die Grinders and Cutting Tools

NEW

- 0.25-0.30 kW (0.33-0.40 HP).
- Composite housing.
- Contains: 1/4" and 6 mm collets.

Accessories: **LG1-K284**
(CPN: 80152119), piped-away exhaust system.

335SC4A - 35 000 rpm

330SC4A - 30 000 rpm

325SC4A - 25 000 rpm

Only 0.4 kg and 166 mm.



330XC4A - 30 000 rpm

325XC4A - 25 000 rpm

Only 0.6 kg



320AC4A - 20 000 rpm

314AC4A - 14 000 rpm

312AC4A - 12 000 rpm

Only 0.55 kg and 170 mm.



NEW

5108MAX

- 0.30 kW (0.40 HP).
- 25 000 rpm.
- Only 0.46 kg and 172 mm.
- Composite housing.
- Contains: 1/4" and 6 mm collets & piped away exhaust kit
- Rear Exhaust



308B

- 0.25 kW (0.33 HP).
- 25 000 rpm.
- Only 0.46 kg and 172 mm.
- Contains: 1/4" and 6 mm collets.
- Rear Exhaust



307B

- 0.19 kW (0.25 HP)
- 28 000 rpm.
- Only 0.33 kg and 125 mm.
- Contains: 1/4" and 6 mm collets.
- Front Exhaust



5102MAX

- 0.30 kW (0.40HP).
- 20 000 rpm.
- Only 0.64 kg and 178 mm.
- Composite housing.
- Contains: 1/4" and 6 mm collets & piped away exhaust kit
- Rear Exhaust



302B

- 0.25 kW (0.33 HP).
- 20 000 rpm.
- Only 0.58 kg and 175 mm.
- Contains: 1/4" and 6 mm collets.
- Rear Exhaust



301B

- 0.19 kW (0.25 HP).
- 21 000 rpm.
- Only 0.46 kg and 128 mm.
- Contains: 1/4" and 6 mm collets.
- Front Exhaust



326

- 18,000 rpm for fast cutting
- Cut mufflers, tail pipes, sheet metal, nuts & bolts
- Steel shield deflects debris away



Replacement collets













301-700B

Collets (Erickson) for 3...C4A

DG110-700-G2	Ø 1/8"
DG110-700-6MM	Ø 6 mm
DG110-700-G4	Ø 1/4"
Collets for 301B, 302B, 307B, 308B, 5102MAX, 5108MAX and LA429-EU	
301-700C	Ø 1/8"
301-700B	Ø 6 mm
301-700	Ø 1/4"

Specifications at 6.2 bar (90 psi)

		 kW	 rpm	 kg	 mm	 NPTF	 mm	 L/s	 L/s	 dB(A)	 m/s ² / K ⁽¹⁾
Straight Grinders											
335SC4A	6mm + 1/4"	0.28	35 000	0.40	166	1/4"	10	3.8	14.2	78.4	3.0 / 0.8
330SC4A	6mm + 1/4"	0.25	30 000	0.40	166	1/4"	10	3.8	14.2	77.2	3.8 / 1.9
330XC4A	6mm + 1/4"	0.25	30 000	0.62	244	1/4"	10	3.8	14.2	80.2	< 2.5
325SC4A	6mm + 1/4"	0.30	25 000	0.40	166	1/4"	10	3.8	15.1	78.6	2.6 / 1.1
325XC4A	6mm + 1/4"	0.30	25 000	0.62	244	1/4"	10	3.8	15.6	78.6	< 2.5
5108MAX	6mm + 1/4"	0.30	25 000	0.46	172	1/4"	10	2.8	11.8	83.3	1.8 / 0.8
308B	6mm + 1/4"	0.25	25 000	0.46	172	1/4"	10	3.3	13.2	92.0	3.7 / 1.2
307B	6mm + 1/4"	0.19	28 000	0.33	125	1/4"	10	2.8	11.3	83.0	4.5 / 1.1
Angle Grinders											
320AC4A	6mm + 1/4"	0.30	20 000	0.55	170	1/4"	10	3.8	15.1	78.6	2.5 / 1.1
314AC4A	6mm + 1/4"	0.25	14 000	0.55	170	1/4"	10	3.8	14.2	80.2	3.2 / 0.7
312AC4A	6mm + 1/4"	0.30	12 000	0.55	170	1/4"	10	3.8	15.1	78.6	3.4 / 1.0
5102MAX	6mm + 1/4"	0.30	20 000	0.64	180	1/4"	10	2.8	11.8	84.1	3.3 / 1.1
302B	6mm + 1/4"	0.25	20 000	0.58	175	1/4"	10	2.8	10.8	90.0	5.5 / 1.5
301B	6mm + 1/4"	0.19	21 000	0.46	128	1/4"	10	2.8	11.3	91.8	5.9 / 1.0
326 (cut-off tool)	N/A	0.38	18,000	1.04	226	1/4"	10	4.7	11.8	94.3	

(1) ISO28927 - 3-axis measurement: vibration level / measurement uncertainty.

Air Die Grinder Kits

301B2MK

Surface Conditioning Kit

Ingersoll Rand has packed the 301B in a strong, blow-molded plastic case along with four coarse and four medium grit 2" Roloc™ surface conditioning pads and a disc holder.



301B32MK

Surface Conditioning Kit

This kit contains the 301B in a strong, blow-molded plastic case along with two coarse and two medium grit 3" Roloc surface conditioning pads, two coarse, two medium grit 2" Roloc surface conditioning pads, and two disc holders.



301B3MK

Surface Conditioning Kit

Four coarse and four medium grit 3" Roloc surface conditioning pads are packed in a strong blow-molded case with our popular 301B grinder.



301BK

Die Grinder Kit

Ingersoll Rand has packed the 301B in a strong, blow-molded plastic case complete with 10 mounted grinding tips.



302BK

Die Grinder Kit

For the ultimate performance and versatility in a lightweight package with superior maneuverability in an angle grinder, the 302B is the perfect choice. The 302B features a composite grip for superior ergonomics and comfort. This powerful grinder can be used in a variety of applications, including porting, weld braking, deburring, grinding, polishing, etc. The kit includes the 302B Grinder, 2" and 3" Quick Change Backing Pads, along with a variety of 2" and 3" Quick Change Sanding Disks, 2" and 3" Quick Change Coarse and Medium Polishing Disks, all packaged in a strong, blow-molded plastic case.



307BK

Die Grinder Kit

The 307BK comes with 10 mounted grinding tips in a strong, blow-molded case.



308BK

Die Grinder Kit

The 308B features a composite grip for superior ergonomics and comfort. These powerful die grinders can be used in various applications including porting, weld braking, deburring, polishing, grinding, and more.



Air Wheel Grinders and Cutting Tools

NEW

- 345MAX-M**
Ø 125 mm (5 in)
- 3445MAX-M**
Ø 115 mm (4.5 in)
- 0.66 kW (0.88 HP).
 - 12 000 rpm.
 - Speed governor.
 - Composite housing.
 - Piped-away exhaust system.



3445MAX-M













- LA422-EU - Ø 125 mm (5 in)**
LA421-EU - Ø 100 mm (4 in)

- 0.50 kW (0.65 HP).
- 12 000 rpm.



LA422-EU

Specifications at 6.2 bar (90 psi)

	 mm	 M14	 kW	 rpm	 kg	 mm	 AIR NPTF	 AIR mm	 L/s	 Max L/s	 dB(A)	 m/s ² / K ⁽¹⁾
345MAX-M	125	M14	0.66	12 000	1.56	245	1/4"	10	4.9	19.3	79.6	7.9 / 0.7
3445MAX-M	115	M14	0.66	12 000	1.53	245	1/4"	10	4.9	19.3	79.6	6.4 / 2.0
LA422-EU	125	3/8"-24	0.50	12 000	1.75	229	1/4"	10	2.8	10.4	85.6	6.0 / 2.1
LA421-EU	100	3/8"-24	0.50	12 000	1.75	229	1/4"	10	2.8	10.4	85.6	4.8 / 1.4

(1) 345MAX & 3445MAX - 5/8" - 11 Spindle thread

(2) ISO28927 - 3-axis measurement: vibration level / measurement uncertainty.

NEW



529

- Stroke: 10 mm (0.4 in).
- 9 500 strokes per minute.
- Only 0.70 kg.
- Variable speed lever.
- 360° adjustable exhaust.
- Contains: blades (6 pieces).



7802SA

- Cutting capacity:
1.0 mm (20-gauge,
0.04 in).
- 4 200 blows per minute.



429

- 10,000 strokes per minute
includes 6 saw blades



4429

- Stroke: 10 mm (0.4 in).
 - 5 000 strokes per minute.
 - Variable speed lever.
 - Piped-away exhaust system.
- Accessories: **P4FS-6** (CPN: 45525474):
blades, 12 teeth/cm (6 pieces).
P4CS-6 (CPN: 45525508): blades,
10 teeth/cm (6 pieces).

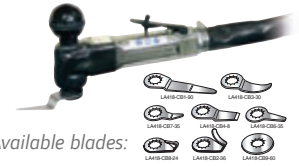

Available blades:



LA418A-EU

- 8 000 strokes per minute.
- Variable speed lever.
- Piped-away exhaust system.
- Supplied without blades.











NEW

325B

- Cutting capacity:
1.2 mm (18-gauge, 0.05 in).
- 4 200 blows per minute.
- Variable speed lever.



Specifications at 6.2 bar (90 psi)

	 1 min.	 mm	 kg	 mm	 AIR NPTF	 AIR mm	 L/s	 Max L/s	 dB(A)	 m/s ² / K ⁽¹⁾
4429 (Saw)	5 000	10 mm	0.74	234	1/4"	6	1.9	3.6	66.2 ⁽²⁾	9.5 / 2.4
529 (Saw)	9 500	10 mm	0.70	246	1/4"	6	0.5	0.5	84.3	3.1 / 1.0
325B (Nibbler)	4 200	-	0.95	185	1/4"	10	1.9	8.0	96.0	15.9 / 1.9
7802SA (Shear)	4 200	-	1.27	239	1/4"	10	1.9	9.9	83.0	3.0 / 1.0
LA418A-EU (Windscreen Cutter)	20 000	3°	1.00	208	1/4"	10	1.8	12.3	90.8 ⁽²⁾	6.7 / 2.5

(1) ISO28927 - 3-axis measurement: vibration level / measurement uncertainty — (2) Piped-away exhaust system.

Air Sanders & Polishers

4151-HL - Ø 150 mm (6 in), orbit 5 mm (3/16 in)

4151-HL-2 - Ø 150 mm (6 in), orbit 5 mm (3/16 in)

4152-HL - Ø 150 mm (6 in), orbit 2.5 mm (3/32 in)

4152-HL-SR - Ø 75 mm (3 in), orbit 2.5 mm (3/32 in)

- 0.15 kW (0.20 HP)
- 12 000 rpm.
- Only 0.86 kg.
- Composite housing.
- Auto-balancer.
- Power regulator.



4152-HL-SR



4151-HL

4152-HL



4151-HL-2

49840



4151JV



Accessories for 4151 and 4152

	Description
4151JV	Jet-Vac conversion kit
49988	Dust collection bags (20 pieces)
49987	Dust collection bags (250 pieces)
4151-747B	Rubber grip
4151-2-747BLK	Rubber grip, long handle

	Description
49801	Rubber grip, small
49798	Rubber grip, medium
49799	Rubber grip, large
49840	Rubber grips (3 pieces: small, medium and large)

311A



- Ø 150 mm (6 in).
- Orbit: 5 mm (3/16 in).
- 0.19 kW (0.25 HP).
- 10 000 rpm.
- Power regulator.



312A

- 93 x 171 mm (3.67 x 6.75 in).
- 0.22 kW (0.30 HP).
- 8 000 strokes per minute.



315

- 70 x 445 mm (2.75 x 17.5 in).
- 3 000 strokes per minute..

313A - 5 000 rpm

314A - 2 500 rpm

- Ø 180 mm (7 in).
- 0.37 kW (0.5 HP).



313A

318A - 2 500 rpm

319A - 5 000 rpm

- Ø 180 mm (7 in).
- 0.6 kW (0.8 HP).



314A

Accessories:

P500-850 (CPN: 03379542)

Wool polishing bonnet for 314A and 318A. Ø 180 mm.

317A

- Ø 75 mm and 125 mm (3 & 5 in).
- 0.35 kW (0.45 HP).
- 18 000 rpm.
- Power regulator.



319A

318A

Air Sanders & Polishers

Ergonomic grip is uniquely designed with an anti-slip rubber compound, providing the ultimate in comfort and style

Patented throttle lever design provides stable, ergonomic hand support

Exhaust silencer includes a multi-stage noise suppression filter for the quietest operation in its class with no sacrifice in performance



8200MAX series

Multi-hole slim backing pad lowers the center of mass, improving tool stability

8000MAX-700: PSA 6" Backing Pad
8000MAX-750: Hoop & Loop 6" Backing Pad











Double bearing design improves protection of the motor from dust and contaminants, thus increasing durability and performance



8100MAX series



Pad wrench storage keeps wrench conveniently available for fast backing pad changes.

	 hp/W	 1 min. rpm	 Orbit Diameter (mm)	 Backing Pad Diameter (mm)	 Backing Pad Type	 Vacuum-Ready	 *m/s ² , K	 ** dB(A)	 kg	 mm	 Max l/min
8101MAX	0.27/200	0-11500	3/32" (2.5)	6" (150)	PSA+	No	8.6/2.8	76	1.65 (.75)	6.3" (160)	12.7 (360)
8102MAX	0.27/200	0-10500	3/16" (5)	6" (150)	PSA+	No	7.0/2.3	76	1.65 (.75)	6.3" (160)	12.7 (360)
8103MAX	0.27/200	0-9500	3/8" (10)	6" (150)	PSA+	No	7.9/2.6	76	1.75 (.80)	6.3" (160)	12.7 (360)
8201MAX	0.27/200	0-11500	3/32" (2)	6" (150)	Hook and Loop	Yes	7.2/2.4	76	1.65 (.75)	7.9" (200)	12.7 (360)
8202MAX	0.27/200	0-10500	3/16" (5)	6" (150)	Hook and Loop	Yes	6.9/2.3	76	1.65 (.75)	7.9" (200)	12.7 (360)
8203MAX	0.27/200	0-9500	3/8" (10)	6" (150)	Hook and Loop	Yes	6.8/2.2	76	1.75 (.80)	7.9" (200)	12.7 (360)

Performance figures are at 90 psi air pressure
Air inlet for all modes is 1/4" NPT
Minimum hose size for all models is 5/16" (8mm)
Backing pad screw thread diameter – M8

* (ISO28927) ** (ISO15744)

+ Pressure Sensitive Adhesive (PSA) Backing Pad provides strong bond to PSA (stick-on) type sanding disc.

Air Sanders & Polishers

NEW



3103XP - Tool only

3103K - Kit

- Ø 75 mm (3 in).
- 0.15 kW (0.2 HP).
- 15 000 rpm.
- Only 0.45 kg and 125 mm.
- Composite housing.
- 2-position power regulator.

3128XP - Tool only

3128K - Kit

- Ø 75 mm (3 in).
- Orbit: 5 mm (3/16 in).
- 0.15 kW (0.2 HP).
- 15 000 rpm.
- Only 0.50 kg and 140 mm.
- Composite housing.
- 2-position power regulator.

3129XP - Tool only

3129K - Kit

- Ø 75 mm (3 in).
- 0.22 kW (0.3 HP).
- 6 000 rpm.
- Only 0.60 kg and 152 mm.
- Composite housing.
- 2-position power regulator.



Kit: 3103K (CPN: 80195597)



Kit: 3128K (CPN: 80195613)



Kit: 3129K (CPN: 80195605)

Accessories



50 and 75 mm quick-change pads & abrasives

CPN	Description	Qty.
50 mm (2") Diameter		
80199177	Quick-change pad with 1/4" mandrel	1
16593386	Coarse coating removal discs	25
16593428	Medium coating removal discs	25
80207574	Quick-strip discs	25
80215023	Aluminum oxide sanding discs, grit 36	25
16593196	Aluminum oxide sanding discs, grit 80	25
75 mm (3") Diameter		
80198963	Quick-change pad with 1/4" mandrel	1
80206238	Coarse coating removal discs	25
80206220	Medium coating removal discs	25
80216690	Quick-strip discs	10
16593238	Aluminum oxide sanding discs, grit 36	25
16593253	Aluminum oxide sanding discs, grit 80	25



75 mm (3") hook-and-loop pad, discs & bonnets

CPN	Description	Qty.
Backer pad		
80199136	Backer pad Ø 75 mm (3 in), hook & loop	1
Aluminum oxide sanding discs		
80207582	Grit 40	50
80206279	Grit 100	50
80206295	Grit 180	50
80206303	Grit 220	50
80206329	Grit 320	50
80206352	Grit 500	50
80205404	Grit 800	50
Polishing Bonnets		
80206170	Wool bonnet (for compounding)	6
80206188	Waffle bonnet / white (for compounding)	6
80206196	Waffle bonnet / yellow (for polishing)	6

Specifications at 6.2 bar (90 psi)

Air Sanders												
4151-HL	150	5/16"-24	0.15	12 000	0.86	190	1/4"	8	3.7	7.2	81.6	7.5 / 1.6
4151-HL-2	150	5/16"-24	0.15	12 000	1.12	252	1/4"	8	3.7	7.2	81.6	6.2 / 1.0
4152-HL	150	5/16"-24	0.15	12 000	0.86	190	1/4"	8	3.7	7.2	81.6	8.2 / 1.7
4152-HL-SR	75	5/16"-24	0.15	12 000	0.84	155	1/4"	8	3.7	7.2	81.6	4.7 / 1.3
311A	150	5/16"-24	0.19	10 000	1.90	248	1/4"	10	8.0	11.8	84.3	32.3 / 5.6
312A	93 x 171	-	0.22	8 000	2.09	171	1/4"	10	4.3	5.7	86.0	7.7 / 1.5
313A	180	5/8"-11	0.37	5 000	2.04	406	1/4"	10	3.8	13.7	88.0	< 2.5
315	70 x 445	-	N/A	3 000	2.77	445	1/4"	10	3.8	4.3	93.3	20.5 / 1.6
317A	125	7/16"-20	0.35	18 000	1.05	104	1/4"	10	5.7	11.8	86.7	3.3 / 0.8
319A	180	5/8"-11	0.60	5 000	2.05	203	1/4"	10	2.8	9.9	85.0	< 2.5
3103XP	75	1/4"-20	0.15	15 000	0.45	125	1/4"	10	1.0	9.2	84.9	3.5 / 1.3
3128XP	75	5/16"-24	0.15	15 000	0.50	140	1/4"	10	1.0	6.9	78.2	5.2 / 0.9
Air Polishers												
314A	180	5/8"-11	0.37	2 500	1.90	406	1/4"	10	3.8	13.7	87.0	< 2.5
318A	180	-	0.60	2 800	2.05	203	1/4"	10	2.8	9.9	85.0	< 2.5
3129XP	75	5/16"-24	0.22	6 000	0.60	152	1/4"	10	1.0	9.4	83.5	3.5 / 1.3

(1) ISO28927 - 3-axis measurement: vibration level / measurement uncertainty.

Air Filters, Regulators & Lubricators

NEW



ARO-Flo Series

Filter + Regulator + Lubricator

- Operating temperature: -5 to +79 °C.
- Maximum inlet pressure: 17.2 bar (250 psig).
- Pressure gauge: 0 to 9.7 bar (0-140 psig).
- 5 micron filter element.

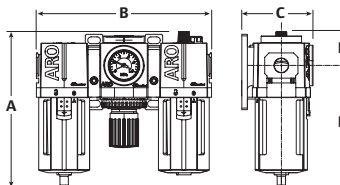

C381B1-821

C383D1-811

5µ filter element

	CPN	AIR BSP	Max. L/s (1)	Bowl material / drain type	5µ filter element CPN
C381B1-821	15302961	1/4"	21.7	Metal / Automatic	15299183
C382C1-811	15315633	3/8"	40.0	Metal / Automatic	15299662
C383D1-811	15304108	1/2"	70.8	Metal / Automatic	15299407
C383E1-811	15304181	3/4"	80.7	Metal / Automatic	15299407
C384F1-811	15317639	1"	101.5	Metal / Automatic	15299878

Dimensions	A mm	B mm	C mm	D mm	E mm
C381B1-821	149	120	80	42	107
C382C1-811	199	168	84	45	154
C383D1-811	216	221	90	43	173
C383E1-811	216	221	90	43	173
C384F1-811	292	282	109	55	237

Filter / Regulator + Lubricator

- Operating temperature: -5 to +52 °C.
- Maximum inlet pressure: 10.3 bar (150 psig).
- Pressure gauge: 0 to 9.7 bar (0-140 psig).
- 5 micron filter element.

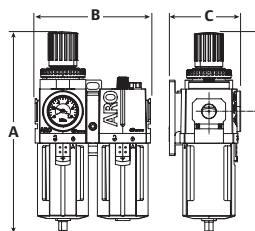

C381B1-600

C383D1-600

	CPN	AIR BSP	Max. L/s (1)	Bowl material / drain type	5µ filter element CPN
C381B1-600	15302896	1/4"	20.7	Polycarbonate / Manual	15299183
C382C1-600	15315567	3/8"	33.5	Polycarbonate / Manual	15299662
C383D1-600	15304033	1/2"	56.7	Polycarbonate / Manual	15299407
C383E1-600	15304116	3/4"	67.0	Polycarbonate / Manual	15299407
C384F1-610	15317605	1"	98.2	Metal / Manual	15299878

Dimensions	A mm	B mm	C mm	D mm	E mm
C381B1-600	157	80	80	67	90
C382C1-600	209	112	84	86	123
C383D1-600	252	145	90	100	152
C383E1-600	252	145	90	100	152
C384F1-610	351	186	109	133	218

Filter / Regulator

- Operating temperature. With polycarbonate bowl: -5 to +52°C. With metal bowl: -5 to +79°C.
- Maximum operating pressure. With polycarbonate bowl: 10.3 bar (150 psig). With metal bowl: 17.2 bar (250 psig).
- Pressure gauge: 0 to 9.7 bar (0-140 psig).
- 5 micron filter element.

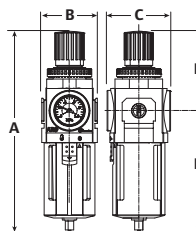

P391B4-600

P393D4-614

Fixing bracket

	CPN	AIR BSP	Max. L/s (1)	Bowl material / drain type	Fixing bracket CPN	5µ filter element CPN
P391B4-600	15302813	1/4"	22.1	Polycarbonate / Manual	15307416	15299183
P391B4-624	15302847	1/4"	22.1	Metal / Automatic	15307416	15299183
P392C4-600	15315260	3/8"	42.5	Polycarbonate / Manual	15307424	15299662
P392C4-614	15315294	3/8"	42.5	Metal / Automatic	15307424	15299662
P393D4-600	15305337	1/2"	79.5	Polycarbonate / Manual	15307432	15299407
P393D4-614	15305360	1/2"	79.5	Metal / Automatic	15307432	15299407
P393E4-600	15305931	3/4"	81.6	Polycarbonate / Manual	15307432	15299407
P393E4-614	15305964	3/4"	81.6	Metal / Automatic	15307432	15299407

Dimensions	A mm	B mm	C mm	D mm	E mm
P391B4-600	157	40	74	67	90
P391B4-624	175	40	74	67	108
P392C4-600	207	56	79	86	121
P392C4-614	229	56	79	86	143
P393D4-600	253	70	80	100	153
P393D4-614	276	70	80	100	176
P393E4-600	253	70	80	100	153
P393E4-614	276	70	80	100	176

(1) At 6.2 bar (90 psig)

Quick Release Couplings & Nipples



		Nipples BSP		Standard couplings		Safety couplings		Safety couplings		
		Part no.	CPN	Part no.	CPN	Part no.	CPN	Part no.	CPN	
Ø 7.2 - 7.4 mm				Max: 16 bar - 25 L/s ⁽¹⁾		Max: 16 bar - 25 L/s ⁽¹⁾		Max: 12 bar - 30 L/s ⁽¹⁾		
	Male thread	1/4" BSP	77NMC2	88104070	7N7CCMC2	25010505	7S7CCMC2	25010398	7S7CMC2	88104187
		3/8" BSP	77NMC3	88104088	7N7CCMC3	25010513	7S7CCMC3	25010406	7S7CMC3	88104195
		1/2" BSP	77NMC4	88104096	7N7CCMC4	25010521	7S7CCMC4	25010414	7S7CMC4	88104203
	Female thread	1/4" BSP	77NFC2	88104047	7N7CCFC2	25010471	7S7CCFC2	25010364	7S7CFC2	88104153
		3/8" BSP	77NFC3	88104054	7N7CCFC3	25010489	7S7CCFC3	25010372	7S7CFC3	88104161
		1/2" BSP	77NFC4	88104062	7N7CCFC4	25010497	7S7CCFC4	25010380	7S7CFC4	88104179
	For hose	Ø 6 mm	77NH06	88104104	7N7CCH06	25010539	7S7CCH06	25010422	7S7CH06	88104211
		Ø 8 mm	77NH08	88104112	7N7CCH08	25010547	7S7CCH08	25010430	7S7CH08	88104229
		Ø 10 mm	77NH10	88104138	7N7CCH10	25010562	7S7CCH10	25010455	7S7CH10	88104245
		Ø 13 mm	77NH13	88104146	7N7CCH13	25010570	7S7CCH13	25010463	7S7CH13	88104252



		Nipples BSP		Standard couplings		Safety couplings		Safety couplings		
		Part no.	CPN	Part no.	CPN	Part no.	CPN	Part no.	CPN	
Ø 6 mm (1/4")				Max: 12 bar - 13 L/s ⁽¹⁾		Max: 16 bar - 15 L/s ⁽¹⁾		Max: 12 bar - 13 L/s ⁽¹⁾		
	Male thread	1/4" BSP	IB6NMC2	88103015	IBN6CMC2	88103197	IBS6CCMC2	25010075	IBS6CMC2	88103098
		3/8" BSP	IB6NMC3	88103023	IBN6CMC3	88103205	IBS6CCMC3	25010083	IBS6CMC3	88103106
		1/2" BSP	-	-	IBN6CMC4	88103213	IBS6CCMC4	25010091	IBS6CMC4	88103114
	Female thread	1/4" BSP	IB6NFC2	88102991	IBN6CFC2	88103163	IBS6CCFC2	25010042	IBS6CFC2	88103064
		3/8" BSP	IB6NFC3	88103007	IBN6CFC3	88103171	IBS6CCFC3	25010059	IBS6CFC3	88103072
		1/2" BSP	-	-	IBN6CFC4	88103189	IBS6CCFC4	25010067	IBS6CFC4	88103080
	For hose	Ø 6 mm	IB6NH06	88103031	IBN6CH06	88103221	-	-	IBS6CH06	88103122
		Ø 8 mm	IB6NH08	88103049	IBN6CH08	88103239	IBS6CCH08	25010117	IBS6CH08	88103130
		Ø 10 mm	IB6NH10	88103056	IBN6CH10	88103247	IBS6CCH10	25010125	IBS6CH10	88103148
Ø 8 mm (3/8")				Max: 12 bar - 33 L/s ⁽¹⁾		Max: 16 bar - 30 L/s ⁽¹⁾		Max: 12 bar - 33 L/s ⁽¹⁾		
	Male thread	1/4" BSP	IB8NMC2	88103296	IBN8CMC2	88104567	-	-	IBS8CMC2	88103395
		3/8" BSP	IB8NMC3	88103304	IBN8CMC3	88104575	IBS8CCMC3	25010158	IBS8CMC3	88103403
		1/2" BSP	IB8NMC4	88103312	IBN8CMC4	88104583	IBS8CCMC4	25010166	IBS8CMC4	88103411
	Female thread	1/4" BSP	IB8NFC2	88103262	IBN8CFC2	88104534	-	-	IBS8CFC2	88103361
		3/8" BSP	IB8NFC3	88103270	IBN8CFC3	88104542	IBS8CCFC3	25010133	IBS8CFC3	88103379
		1/2" BSP	IB8NFC4	88103288	IBN8CFC4	88104559	IBS8CCFC4	25010141	IBS8CFC4	88103387
	For hose	Ø 8 mm	IB8NH08	88103320	-	-	IBS8CCH08	25010174	IBS8CH08	88103429
		Ø 10 mm	IB8NH10	88103338	IBN8CH10	88104609	IBS8CCH10	25010182	IBS8CH10	88103437
		Ø 13 mm	IB8NH13	88103346	IBN8CH13	88104617	IBS8CCH13	25010190	IBS8CH13	88103445
Ø 11 mm (1/2")						Max: 16 bar - 70 L/s ⁽¹⁾				
	Male thread	3/8" BSP	IB11NMC3	25014028	-	-	IBS11CCMC3	25013939	-	-
		1/2" BSP	IB11NMC4	25014036	-	-	IBS11CCMC4	25013947	-	-
		3/4" BSP	-	-	-	-	IBS11CCMC6	25013954	-	-
	Female thread	3/8" BSP	IB11NFC3	25014002	-	-	IBS11CCFC3	25013905	-	-
		1/2" BSP	IB11NFC4	25014010	-	-	IBS11CCFC4	25013913	-	-
		3/4" BSP	-	-	-	-	IBS11CCFC6	25013921	-	-
	For hose	10 mm	IB11NH10	25014044	-	-	IBS11CCH10	25013962	-	-
		13 mm	IB11NH13	25014051	-	-	IBS11CCH13	25013970	-	-
		16 mm	IB11NH16	25014069	-	-	IBS11CCH16	25013988	-	-
		19 mm	IB11NH19	25014077	-	-	IBS11CCH19	25013996	-	-

(1) Measured at 6 bar (87 psig) at inlet, with 10% pressure drop as per industry standard.

Air Hoses

Polyurethane Recoil Hoses

- Operating temperature: -40 to +38 °C.
- Operating pressure: 8 bar (115 psi) at 24 °C.

	CPN	mm	NPT	m	m	m
Yellow Hose						
34102	92833375	6	1/4"	3	2.5	0.15
34202	92833383	6	1/4"	6	5	0.31
34302	92833391	6	1/4"	9	8	0.43
35102	92833409	8	1/4"	3	2.5	0.14
35202	92832526	8	1/4"	6	5	0.30
35302	92833417	8	1/4"	9	8	0.46
IR36103	92835172	9.5	1/4"	3	2.5	0.15
IR36203	92835180	9.5	1/4"	6	5	0.34
IR36303	92835198	9.5	1/4"	9	8	0.52
IR36102	92835149	9.5	3/8"	3	2.5	0.15
IR36202	92835156	9.5	3/8"	6	5	0.34
IR36302	92835164	9.5	3/8"	9	8	0.52
IR37102	92835206	13	1/2"	3	2.5	0.16
IR37202	92835214	13	3/8"	6	5	0.38
Blue Hose						
IR36713	88098991	9.5	3/8"	6	5	0.34
IR36715	88099015	9.5	3/8"	9	7.5	0.52

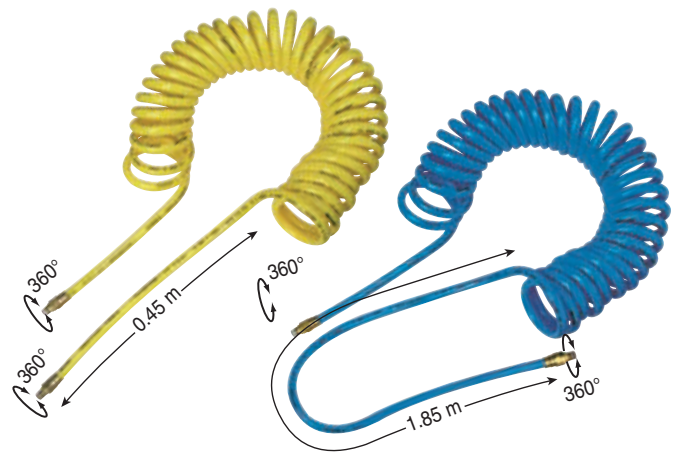

PVC Round Hose, 30 m Coil

- Safety factor 4:1.

	CPN	mm	mm	Max. operating pressure at 20° C
RH-6	92545730	6 mm	11 mm	18 bar
RH-8	92536036	8 mm	13 mm	15 bar
RH-10	92536044	10 mm	14 mm	13 bar
RH-12	92536051	13 mm	17 mm	11 bar
RH-16	92536069	16 mm	21 mm	11 bar
RH-19	92536077	19 mm	24 mm	11 bar

Hose Whips



	CPN	NPT	mm
33104	91486340	1/4" NPT	300 mm
33204	91486357	3/8" NPT	300 mm
33304	91488205	1/2" NPT	300 mm

Hose Clamps



	CPN	mm	Quantity
CO-0911	56753080	Ø 9 - 11 mm	100
CO-1113	56753098	Ø 11 - 13 mm	100
CO-1315	56753106	Ø 13 - 15 mm	100
CO-1518	56753122	Ø 15 - 18 mm	100
CO-1821	56753148	Ø 18 - 21 mm	100
CO-2225	56753163	Ø 22 - 25 mm	100

Lubricants



Lubricant Kits

Contains: grease 80 g, oil 0.12 L and grease pump.

- **67-LBK1** (CPN: 04637344) for angle head tools.
- **105-LBK1** (CPN: 04616090) for Impacttools with metal housing.
- **115-LBK1** (CPN: 04616108) for Impacttools with composite housing.



	CPN	No.	Description / Recommended use	Capacity
Grease				
67-4T	04637336	67	For angle head tools	0.12 L (tube)
67-1 LB	03773009			0.45 kg
105-4T-6	04618930	105	For Impacttools with metal housing	6 tubes of 0.12 L
105-1LB	04279147			0.45 kg
105-8LB	04264875			3.60 kg
115-4T	04616157			0.12 L (tube)
115-1LB	04192480	115	For Impacttools with composite housing	0.45 kg
Oil				
10Z4	03875671	10	For Impacttools, drills, screwdrivers and percussive tools	0.12L (tube)
10P	03875689			0.50 L
10G	03875697			3.80 L
50P	03875705			0.50 L
50G	03875713	50	For grinders and Impacttools	3.80 L



Ingersoll Rand (NYSE:IR) advances the quality of life by creating comfortable, sustainable and efficient environments. Our people and our family of brands — including Club Car®, Ingersoll Rand®, Thermo King® and Trane® — work together to enhance the quality and comfort of air in homes and buildings; transport and protect food and perishables; and increase industrial productivity and efficiency. We are a \$12 billion global business committed to a world of sustainable progress and enduring results.



www.ingersollrandproducts.com



Distributed by: