

# LED 19\*15W RGBW Moving Head Light With AURA

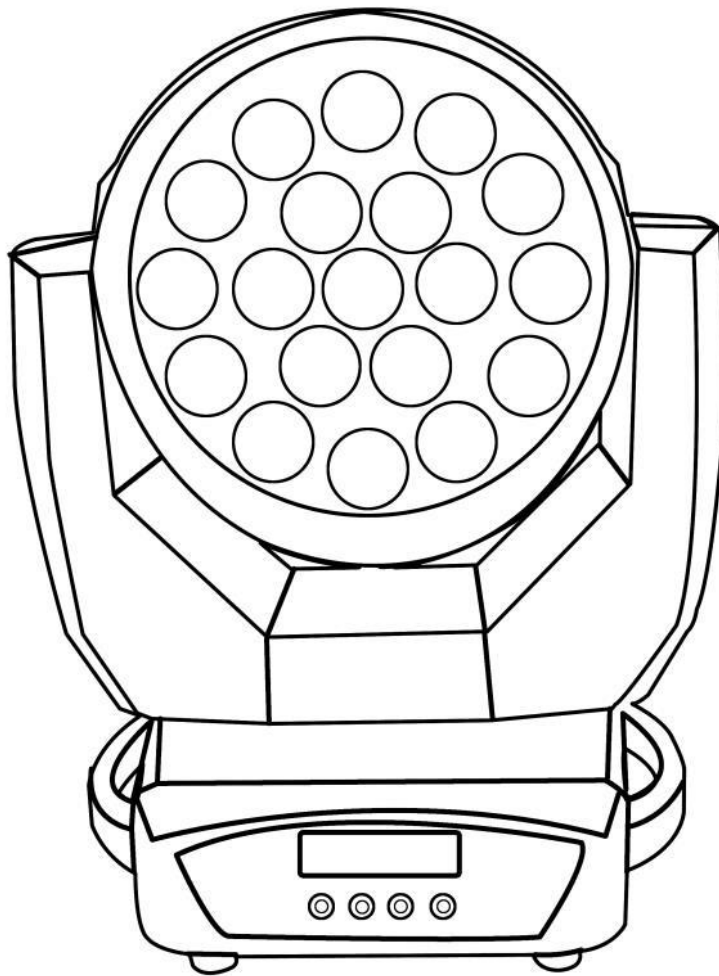

AURA1915

manual

Thank you for choosing to use our LED 19-piece focusing and dyeing moving head light. In order to use this product correctly and safely, please read the instructions carefully before installing and using this product. This manual contains important installation and application information. When installing and operating the product, please strictly follow the instructions. At the same time, please keep this manual properly.

Our 19 LED focusing and dyeing moving head lights use a new and beautiful high temperature resistant metal body. This product is designed and produced in strict accordance with CE standards. It is in line with the international standard DMX512 signal protocol. It can be used alone for control or online use. It has the characteristics of fast rotation, low noise, and powerful functions. It is suitable for small and medium concerts, theaters, Studios, nightclubs, bars and other places

This product uses high-brightness and stable LED (4IN1-R G B W) lamp beads. Please remove the package carefully. After the package is removed, check whether the product is damaged during transportation, and check whether the following contents are complete.

Moving head light-----1

Quick lock-----2

manuals-----1

Power line -----1

signal line -----1

**This product is intact before leaving the factory. To keep the product in good condition and ensure safe operation, users should follow the safety matters and the warnings in this manual.**

**Important: Damage caused by not following this manual is not covered by the warranty**

The supplier is not responsible for product problems caused by this.

If the product has been exposed to an extremely unstable temperature environment (such as after transportation), please do not immediately connect the product to the power supply, because the water droplets generated due to temperature changes may damage the product. Please use the product after returning to normal temperature.

This product can be used in the voltage range of 90-240V and is a product for indoor use. Please ensure that the ground voltage is not higher than the product's acceptable range! ! The power plug must be plugged into a protective Class I socket. The green or tea-cyan conductor must be grounded.

Please check the power cord of this product frequently. Make sure that the power cord is not folded or damaged or scratched, and not connected to other cords! Pay special attention when connecting the power cord or related wiring. When not using this product or before cleaning, be sure to unplug the power supply.

Before using the product, please familiarize yourself with the operating functions of the product. Please do not let children or unprofessionals touch the product. Please do not shake this product. Do not use brute force when installing or operating the product. Do not let unprofessionals operate the product. Most of the damage is caused by unprofessional

operation.

The product is not equipped with related repair parts. Product maintenance and repair can only be carried out by professionals!

Please do not modify this product without authorization, otherwise the product may be damaged, so the damage caused is not covered by the warranty. Moreover, unprofessional operations may cause short circuits, burns or electric shocks, etc.

### DMX512 signal connection:

This lamp uses the DMX512 signal control mode. The control signals of each lamp are in a parallel relationship. When connecting the signals of multiple lamps, it is best to use a double-core shielded cable. When connecting, each lamp is connected through the DMX signal jack on the lamp. Socket) INPUT (input) and OUTPUT (output) are connected. The 3-pin XLR plug terminals of the signal cable connected to the lamp must correspond to each other. When connecting the signal of the lamp, it is recommended to use a DMX signal terminator. It can be avoided due to electrical drying. Sound can cause damage to the control signal. The DMX signal terminator is a 120 ohm 1W resistor connected between pin 2 and pin 3 of an XLR plug, and connect it to the OUTPUT jack of the last lamp.

### Calculation method of lamp start address code:

The starting address code of the current fixture is equal to (the starting address code of the previous fixture) + (the number of channels of the fixture)

1: The starting address code value of the first lamp is A001.

2: The number of basic channels of the controller should be greater than or equal to the total number of channels used by the lamp.

3: Note: When using any controller, each lamp must have its own start address code. If the start address code of the first lamp is set to A001, the number of lamp channels is 14CH; then The start address code of the two lamps is set to A015; the start address code of the third lamp is set to A029; and so on, (this setting method also needs to be determined according to different consoles)

### Detailed explanation of LCD window:

#### Menu desktop:

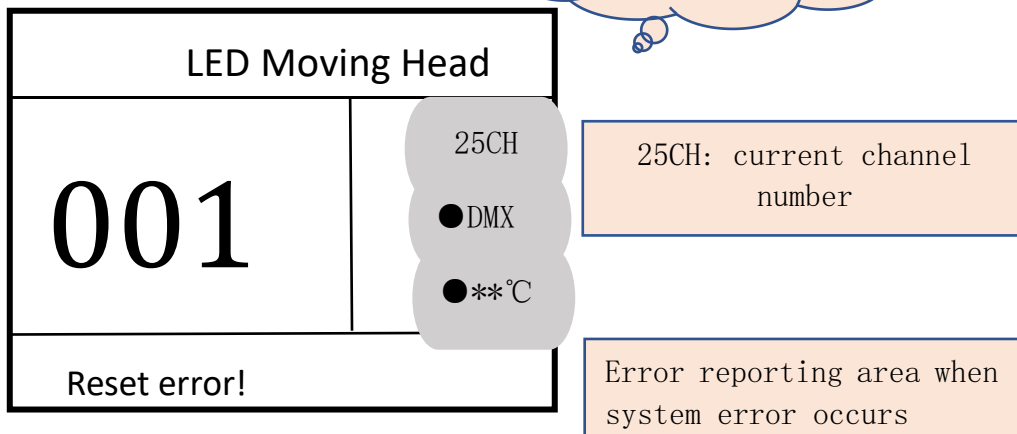

## Menu first interface:



Address: Click to enter the address code setting

Settings: Click to enter system settings

Test: Click to enter manual mode

Calibration: Click to enter the password to enter the system calibration mode

Reset: Click to enter the system reset mode

Information: Click to enter to view system information

## Menu description:

主菜单	次级菜单	三级菜单/参数
address	001 - 512	
Set up	Operating mode	DMX
		Auto
		Voice control
	Local number	000 - 255
	Channel mode	14CH
		25CH
	Horizontal reversal	switch
	Vertical reverse	switch
Horizontal and vertical swap	switch	
Motor position error correction	switch	

	Signal hold	Keep/clear
	screen protector	switch
	Language	Chinese/English
	reset	confirm cancel
test	Corresponding to the current channel	
calibration	enter password	Lamp calibration
Reset	Reset all	
information	Current information	

## Parameter

Input voltage: AC90-260V 50-60HZ

Main LED: 19 15w high power RGBW 4 in 1 LED

Backlight LED: 30 0.18w RGB 3 in 1 LED

Dimming: 0%-100% linear dimming

Control mode: DMX512, voice control, automatic, master/slave

DMX channel: 14/25CH

Strobe: 1-25 times/sec random strobe

Beam zoom: 10-60°

## Channel

### 14CH

C H	Function	Value	content
1	Strobe	0 - 19	Turn off dimming
		20 - 24	Turn on dimming
		25 - 64	Strobe light 1 (fast-slow)
		65 - 69	turn on
		70 - 84	Strobe 2: Turn on pulse (fast-slow)
		85 - 89	turn on
		90 - 104	Flash 3: Turn off pulse (fast-slow)
		105 - 109	turn on
		110 - 124	Strobe 4: Random strobe (fast-slow)
		125 - 129	turn on
		130 - 144	Strobe 5: random turn on pulse (fast-slow)
		145 - 149	turn on
		150 - 164	Strobe light 6: turn off pulse randomly (fast-slow)
		165 - 169	turn on
170 - 184	Strobe 7: burst pulse (fast-slow)		

		185 – 189	turn on
		190 – 204	Strobe 8: random burst pulse (fast-slow)
		205 – 209	turn on
		210 – 224	Strobe 9: Sine wave (fast-slow)
		225 – 229	turn on
		230 – 244	Strobe 10: continuous shooting (fast-slow)
		245 – 255	turn on
2	Dimming	0 – 255	0–100%
3	focusing	0 – 255	Linear focus
4	X axis	0 – 255	Horizontal 0° -540°
5	X-axis fine adjustment	0 – 255	Level fine adjustment
6	Y axis	0 – 255	Vertical 0° -232°
7	Y-axis fine adjustment	0 – 255	Vertical fine adjustment
8	Macro function	0 – 9	No function
		10–14	Reset
		15 – 39	No function
		40 – 44	PTSP = NORM2
		45 – 49	PTSP = FAST2
		50 – 54	PTSP = SLOW2
		55 – 59	No function
		60 – 64	Fan fast mode
		65 – 69	No function
		70 – 74	Fan low speed mode
		75 – 89	No function
		90 – 94	Calibrated color output mode COLOR CALIB = ON3
		95 – 99	No function
		100 – 104	Original color output mode COLOR CALIB = OFF3
		105 – 109	No function
		110 – 114	Fast dimming, unlimited change speed 2
		115 – 119	No function
120 – 124	Smooth dimming, slightly limited change speed 2		
125 – 249	No function		
		250 – 255	Illuminate the display
9	colour	0 – 9	Turn on RGBW color mixing
		10 – 14	Moroccan pink
		15 – 19	Pink
		20 – 24	Special rose pink
		25 – 29	Fool fan
		30 – 34	Fuchsia pink
		35 – 39	Surprise pink

		40 - 44	Congo blue
		45 - 49	Tokyo blue
		50 - 54	Navy blue
		55 - 59	blue
		60 - 64	Medium blue
		65 - 69	Double CT Blue
		70 - 74	Slate blue
		75 - 79	Full CT blue
		80 - 84	Half CT blue
		85 - 89	Steel blue
		90 - 94	Light blue
		95 - 99	Light blue
		100 - 104	Medium blue green
		105 - 109	dark green
		110 - 114	light green
		115 - 119	Moss green
		120 - 124	Fern green
		125 - 129	JAS green
		130 - 134	lemon green
		135 - 139	Spring yellow
		140 - 144	Dark amber
		145 - 149	Chrome orange
		150 - 154	Orange
		155 - 159	Golden amber
		160 - 164	Daughter
		165 - 169	Dark golden amber
		170 - 174	Flame red
		175 - 179	turn on
		180 - 201	Clockwise, fast to slow
		202 - 207	stop
		208 - 229	Counterclockwise, slow to fast
		230 - 234	turn on
		235 - 239	Random and fast
		240 - 244	Random medium speed
		245 - 249	Random slow
		250 - 255	turn on
1 0	red	0 - 255	Red 0-100%
1 1	green	0 - 255	Green 0-100%
1 2	blue	0 - 255	Blue 0-100%

1 3	white	0 - 255	White 0-100%
1 4	CTC (color temperature control)	0 - 19	NO CTC
		20 - 255	CTC 10 000K - 2 500K

## 25CH

CH	Function	Value	content
1	Strobe	0 - 19	Turn off dimming
		20 - 24	Turn on dimming
		25 - 64	Strobe light 1 (fast® slow)
		65 - 69	turn on
		70 - 84	Strobe 2: Turn on pulse (fast® slow)
		85 - 89	turn on
		90 - 104	Flash 3: Turn off pulse (fast® slow)
		105 - 109	turn on
		110 - 124	Strobe 4: Random strobe (fast® slow)
		125 - 129	turn on
		130 - 144	Strobe 5: random turn on pulse (fast® slow)
		145 - 149	turn on
		150 - 164	Strobe light 6: turn off pulse randomly (fast ® slow)
		165 - 169	turn on
		170 - 184	Strobe 7: Burst pulse (fast® slow)
		185 - 189	turn on
		190 - 204	Strobe 8: random burst pulse (fast® slow)
		205 - 209	turn on
		210 - 224	Strobe 9: Sine wave (fast® slow)
		225 - 229	turn on
230 - 244	Strobe 10: continuous shooting (fast® slow)		



		245 – 255	turn on
2	Dimming	0 – 255	0-100%
3	focusing	0 – 255	Linear focus
4	X axis	0 – 255	Horizontal 0° -540°
5	X-axis fine adjustment	0 – 255	Level fine adjustment
6	Y axis	0 – 255	Vertical 0° -232°
7	Y-axis fine adjustment	0 – 255	Vertical fine adjustment
8	Macro function	0 – 9	No function
		10 – 14	Reset
		15 – 39	No function
		40 – 44	PTSP = NORM2
		45 – 49	PTSP = FAST2
		50 – 54	PTSP = SLOW2
		55 – 59	No function
		60 – 64	Fan fast mode
		65 – 69	No function
		70 – 74	Fan low speed mode
		75 – 89	No function
		90 – 94	Calibrated color output mode COLOR CALIB = ON3
		95 – 99	No function
		100 – 104	Original color output mode COLOR CALIB = OFF3
		105 – 109	No function
		110 – 114	Fast dimming, unlimited change speed 2
		115 – 119	No function
120 – 124	Smooth dimming, slightly limited change speed 2		
125 – 249	No function		
250 – 255	Illuminate the display		
9	colour	0 – 9	turn on. Enable RGBW color mixing
		10 – 14	Moroccan pink
		15 – 19	Pink
		20 – 24	Special rose pink
		25 – 29	Fool fan
		30 – 34	Fuchsia pink

35 - 39	Surprise pink
40 - 44	Congo blue
45 - 49	Tokyo blue
50 - 54	Navy blue
55 - 59	blue
60 - 64	Medium blue
65 - 69	Double CT Blue
70 - 74	Slate blue
75 - 79	Full CT blue
80 - 84	Half CT blue
85 - 89	Steel blue
90 - 94	Light blue
95 - 99	Light blue
100 - 104	Medium blue green
105 - 109	dark green
110 - 114	light green
115 - 119	Moss green
120 - 124	Fern green
125 - 129	JAS green
130 - 134	lemon green
135 - 139	Spring yellow
140 - 144	Dark amber
145 - 149	Chrome orange
150 - 154	Orange
155 - 159	Golden amber
160 - 164	Daughter
165 - 169	Dark golden amber
170 - 174	Flame red

		175 – 179	turn on
		180 – 201	Clockwise, fast® slow
		202 – 207	stop
		208 – 229	Counterclockwise, slow ® fast
		230 – 234	turn on
		235 – 239	Random and fast
		240 – 244	Random medium speed
		245 – 249	Random slow
		250 – 255	turn on
10	red	0 – 255	Red 0-100%
11	green	0 – 255	Green 0-100%
12	blue	0 – 255	Blue 0-100%
13	white	0 – 255	White 0-100%
14	CTC (color temperature control)	0 – 19	NO CTC
		20 – 255	CTC 10 000K-2 500K
15	FX1 (Effect 1)	0 – 4	No function
		5 – 255	Pre-programmed effect 1 selection
16	Effect 1 speed	0 – 255	Slow to fast <ul style="list-style-type: none"> <li>• If synchronization is not set on channel 19, please adjust FX1</li> <li>• If synchronization is set on channel 19, adjust the synchronized FX1 + FX2 speed</li> </ul>
17	FX2 (Effect 2)	0 – 4	No function
		5 – 255	Pre-programmed effect 2 selection
18	Effect 2 speed	0 – 255	Slow to fast <ul style="list-style-type: none"> <li>• If synchronization is not set on channel 19, please adjust FX2</li> <li>• If synchronization is set on channel 19, it is invalid</li> </ul>
19	Operation effect mode	0 – 5	No sync
		6 – 255	Speed synchronization

20	Backlight strobe	0 - 19	Turn off dimming
		20 - 24	Turn on dimming
		25 - 64	Strobe light 1 (fast® slow)
		65 - 69	turn on
		70 - 84	Strobe 2: Turn on pulse (fast® slow)
		85 - 89	turn on
		90 - 104	Flash 3: Turn off pulse (fast® slow)
		105 - 109	turn on
		110 - 124	Strobe 4: Random strobe (fast® slow)
		125 - 129	turn on
		130 - 144	Strobe 5: random turn on pulse (fast® slow)
		145 - 149	turn on
		150 - 164	Strobe light 6: turn off pulse randomly (fast ® slow)
		165 - 169	turn on
		170 - 184	Strobe 7: Burst pulse (fast® slow)
		185 - 189	turn on
		190 - 204	Strobe 8: random burst pulse (fast® slow)
		205 - 209	turn on
		210 - 224	Strobe 9: Sine wave (fast® slow)
		225 - 229	turn on
230 - 244	Strobe 10: continuous shooting (fast® slow)		
245 - 255	turn on		
21	Backlight dimming	0 - 255	0-100%
22	Backlight color	0 - 9	turn on. Enable RGBW color mixing
		10 - 14	Moroccan pink
		15 - 19	Pink
		20 - 24	Special rose pink
		25 - 29	Fool fan

30 - 34	Fuchsia pink
35 - 39	Surprise pink
40 - 44	Congo blue
45 - 49	Tokyo blue
50 - 54	Navy blue
55 - 59	blue
60 - 64	Medium blue
65 - 69	Double CT Blue
70 - 74	Slate blue
75 - 79	Full CT blue
80 - 84	Half CT blue
85 - 89	Steel blue
90 - 94	Light blue
95 - 99	Light blue
100 - 104	Medium blue green
105 - 109	dark green
110 - 114	light green
115 - 119	Moss green
120 - 124	Fern green
125 - 129	JAS green
130 - 134	lemon green
135 - 139	Spring yellow
140 - 144	Dark amber
145 - 149	Chrome orange
150 - 154	Orange
155 - 159	Golden amber
160 - 164	Daughter
165 - 169	Dark golden amber
170 -	Flame red

		174	
		175 – 179	turn on
		180 – 201	Clockwise, fast® slow
		202 – 207	stop
		208 – 229	Counterclockwise, slow ® fast
		230 – 234	turn on
		235 – 239	Random and fast
		240 – 244	Random medium speed
		245 – 249	Random slow
		250 – 255	turn on
23	Backlight red	0 – 255	Red 0-100%
24	Backlight green	0 – 255	Green 0-100%
25	Backlight blue	0 – 255	Blue 0-100%

## Product hanging and installation

**Note:** For more safety, please hang this product away from the aisle, seating area, or an area within reach of human hands. Before hanging this product, make sure that the installation point can bear the weight of the product 10 times. Product installation must have double protection devices, such as safety ropes. When hanging, dismantling or repairing this product, it is forbidden to stand under the installation point. Please make sure that this product should be installed at least 0.5 meters away from flammable materials. Please remember to use a safety rope as a safety guarantee to prevent accidents when the lock is loosened.

### Lifting Point:

The top hanging requires that the installer must be experienced, including calculating the load-bearing requirements, the installation materials used, and periodically checking the safety conditions of the installation materials and products. If you lack this knowledge, please do not try to install it yourself. If it is not operated correctly, it may cause serious consequences such as personal injury. Before powering on the product, be sure to complete all required hanging and installation steps.

### Quickly lock and hang:

There are specially designed professional hanging parts at the bottom of this product, including quick-locking hanging parts and safety rope hanging points (please refer to the figure below). When hanging the product on a truss, please remember to use a suitable quick-locking lock, fix it to the quick-locking hanger position of the product, and use M10 screws to hang it. To further ensure safety, please install the safety rope on the safety rope hanging point at the bottom of the product and fix it to the truss.

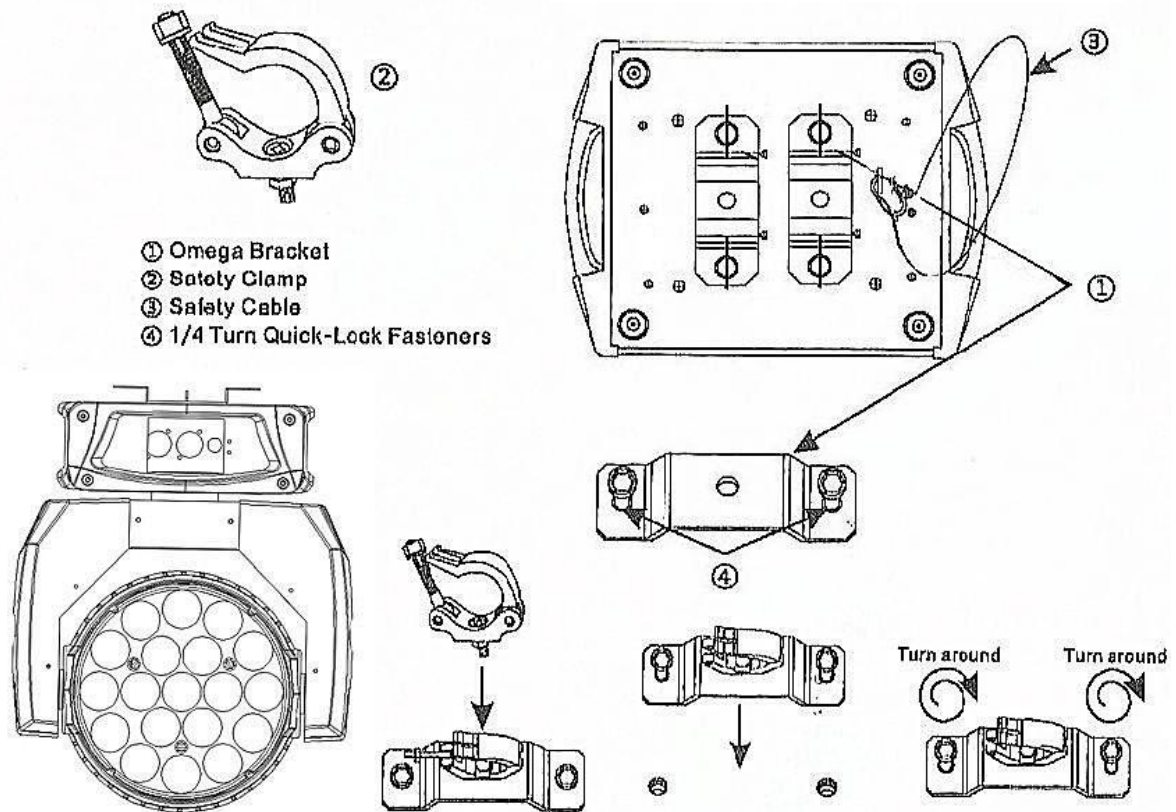

No matter what kind of hanging you choose, please remember to use a safety rope. There is a special safety rope hanging point at the bottom of the product, please refer to the above picture, and please remember to use the specially provided safety rope hanging point, and never install the safety rope on the handle position.

## DMX-512 control connections:

Please insert the male end of the XLR signal cable equipped with this product into the signal output port of the controller, and insert the female end into the signal input port on the rear panel of this product. You can connect multiple products in series, the signal line needs to be three-core, shielded, with XLR input and output. Please refer to the figure below.

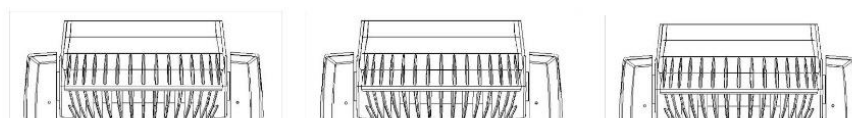
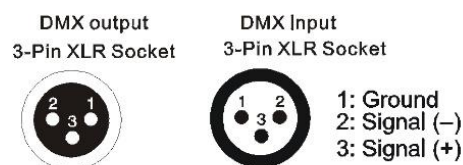

## **Shutdown operation:**

Before each power off, turn off the lamp for 10 minutes in advance. Let the heat dissipation fan quickly discharge the heat generated in the lamp during use, which can extend the life of the accessories in the lamp, especially the bulb! In order to ensure that the lamp can operate stably, it should be kept clean. Before disassembling the lamp for repair or starting maintenance work, confirm whether the power supply is disconnected. It is very important to keep the lamp clean and clean. Please clean it regularly. Maintain the maximum brightness output, and can also extend the service life of the lamp. It is recommended to use high-quality glass cleaner and a clean soft cloth to clean the lamp. Use a vacuum cleaner to clean the inside of the lamp at least half a year.

## **After-sales service**

Note! When the lamps leave the factory, they have undergone strict quality inspections, and the packaging is intact. Please operate according to the instruction manual. The machine failure caused by human causes is not covered by the warranty.

The company provides technical advice to customers throughout their lives.

If the product fails and needs to be repaired, please show the product warranty card and fill in the relevant content truthfully. At the same time, we also hope that customers will promptly feedback the product problems to us, so that we can improve the product in the first time.