



the toolmaker
GOVONI®

User manual





MADE IN ITALY

GO 434

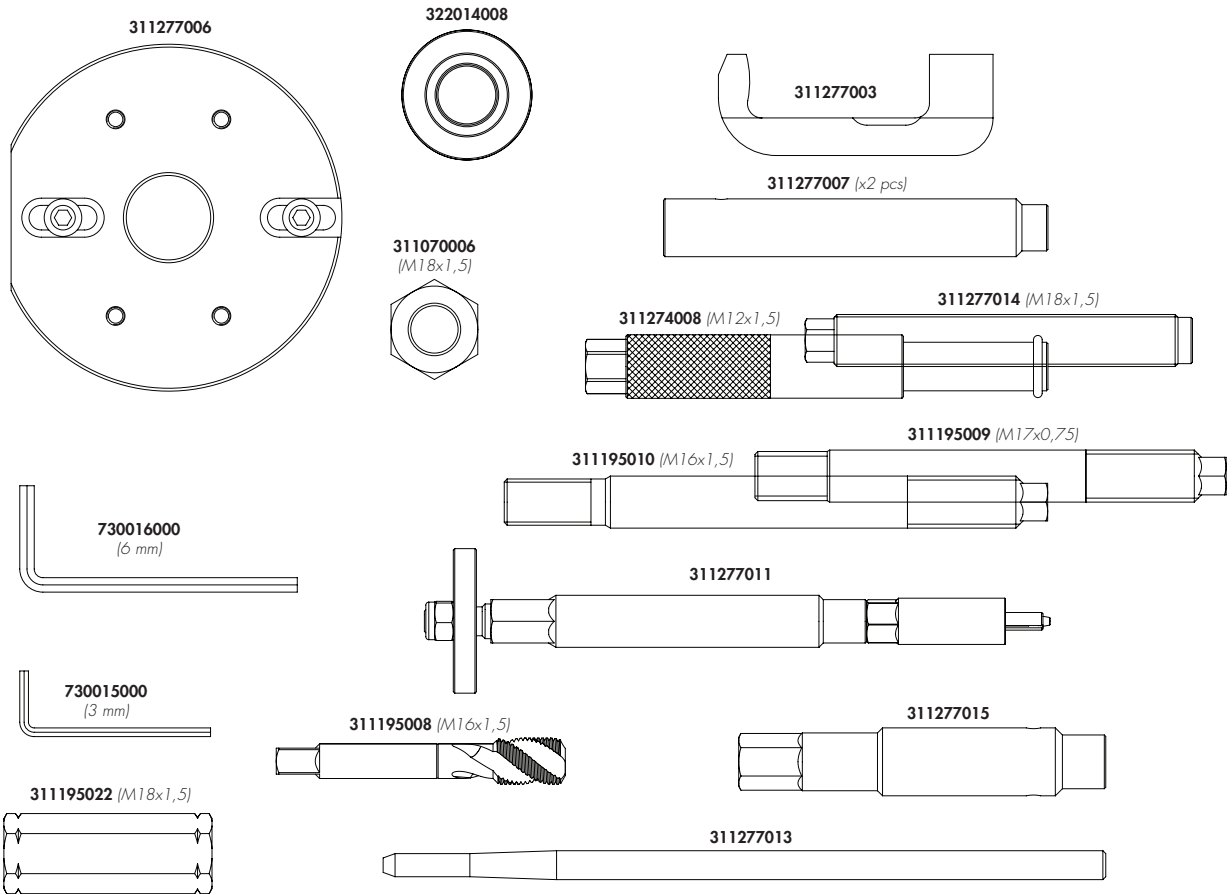

Injector set for Ford 2.0 Ecoblue TDCi

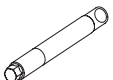
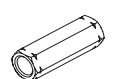

Componenti

311195008	MALE THREADING M16X1.5 L=100	
311195009	EXTRACTOR THREAD M16x1.5	
311195010	EXTRACTOR THREAD M17x0.75	
311195022	NUT M18x1.5 - 24 mm WRENCH L=72	
311070006	NUT M18x1.5 30 mm WRENCH	
311274008	SCREW EXTRACTOR M12X1,5	
311277003	FORK EXTRACTOR	

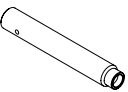
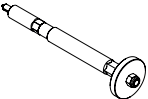
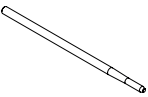
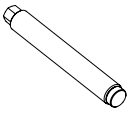
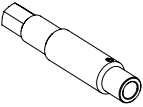
Componenti

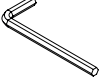
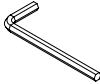
311277006	SUPPORT PLATE	
311277007	COLUMN FOR SUPPORT PLATE	
311277011	EXPANDER TOOL FOR DISASSEMBLING THE NOZZLE	
311277013	MAGNET Ø5	
311277014	SPINDLE M18x1.5 WITH PROTECTION PLUG	
311277015	M16x1.5 MALE EXTENSION WITH GRAIN	
322014008	CENTERING BUSHING WITH BEARING	
730015000	WRENCH SW6 mm	
730016000	WRENCH SW3 mm	

INTRODUCTION

Use protective work gloves, protective footwear, hard hat and safety goggles.

Misuse:

- This product should only be used as described in this documentation; any other use is considered improper.
- The manufacturer accepts no responsibility for any damage caused by the incorrect or unreasonable use of the equipment.
- Moreover, misuse shall also void the warranty.

Take care of your tools:

- Be sure to store your tools in a clean state.
- Place the tools inside their original package.

WARNINGS

This tool set should be used by experienced personnel only.

Special tool sets to disassemble and remove blocked injectors directly on the car.

INJECTOR REMOVAL OPTIONS

1. Removal of the complete injector by means of a fork extractor

Advantage: there is no need to perform a partial removal; the injector can be reused.

2. Removal of the injector on the original thread – the injector's main body is unscrewed.

3. Removal of the damaged injector through its restored thread.

The injector is removed using the tools included in the set. A new M16x1.5 support thread is made in the socket at the end of the injector. Now you can screw in the M16x1.5 thrust screw and remove the remaining part of the injector.

For particularly blocked injectors, it is advisable to use our 12-TON mechatronic cylinder, GO1015.

 **Warning:** does not apply for use with the fork extractor.

1

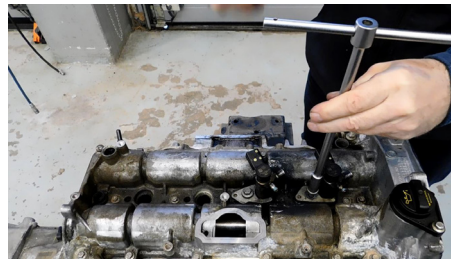

2

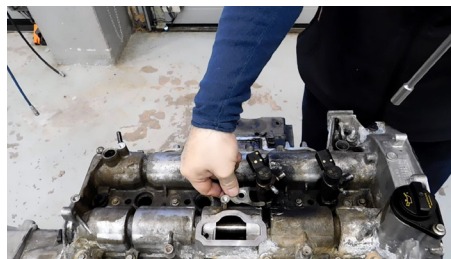

3

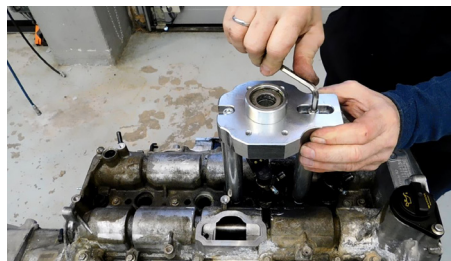

4

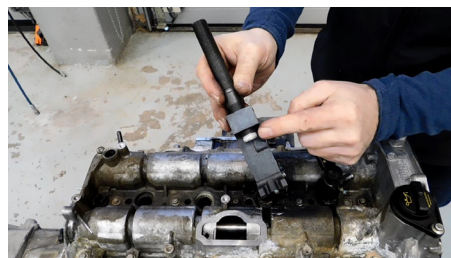

5



6



1) Removal of the injector with the fork extractor

In this way, you can remove most injectors without partial disassembly and/or damage. The injectors can then be reused.

Remove the injector's clamping brackets and mount the support feet to the cross member. (Fig. 1+2)

Warning: the support feet must always be positioned on the injector head's screws, which are located directly on the right and on the left next to the injector. Install the bridge on the head's screws – pre-adjust the feet and fix using the Allen wrench. (Fig. 3)

Slightly screw the M18 thrust screw with the plastic insert into the extraction fork (Fig. 4) and place the fork on the injector.

Warning: the fork grasps the injector where the clamping bracket was previously mounted. Now insert the thrust screw all the way into the extraction fork until the plastic insert exerts some pressure on the injector's flat head. (Fig. 6)

Then rest the previously installed bridge on the valve cover screws with the support feet and insert the screw through the cross member hole. (Fig. 7) Now insert the thrust bearing into the cross member (Fig. 8) and screw the pressure nut onto the thrust screw. (Fig. 9) The injector will be uniformly removed by acting on the nut.

Warning: during the entire removal procedure, make sure not to deform the extraction fork. If need be, stop the procedure to avoid damaging the tool.

The injector has now been completely removed and can be reused after having properly cleaned it. (Fig. 10+11)

The supply includes a handle that is screwed to the pipe fitting of the Common Rail injector, which allows you to rotate the injector inside its seat.

Warning: the following Govoni solutions are available for cleaning the injector seat:

- GO415 Milling and cleaning tool set for injectors, 28 items
- GO401 Milling and cleaning tool set for injectors, 31 items
- GO433 Vibrofighter tool set for removing and cleaning injector seats, 28 items.

7

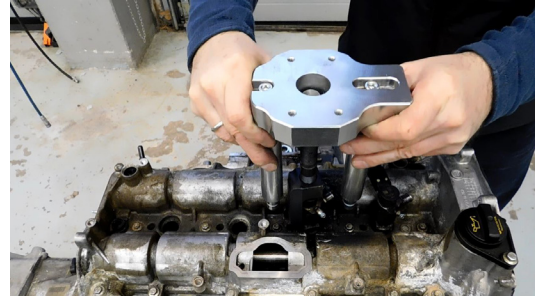

8

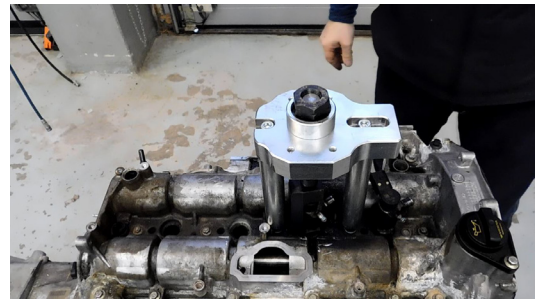

9



10

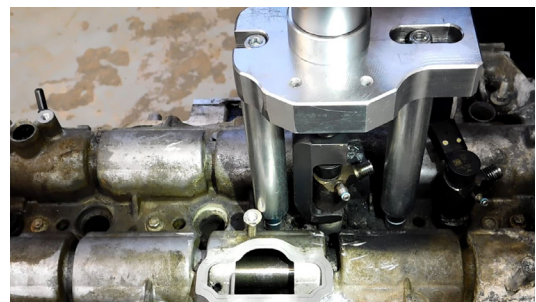

11



2) Injector removal with M17x0.75 thrust screw, after the main body (upper part) of the injector has been removed

Thanks to this method you can extract strongly seized injectors due to rust or coking and which cannot be removed with the fork extractor. In this case the problem is caused by one end of the injector the head of which is extremely blocked and must be removed separately. In order to do this, you must unscrew the injector's main body. Therefore, disconnect the electrical socket and the fuel return pipe using a set of pliers.

Now you can unscrew the injector's main body using an appropriate tool such as the bush insert (OE 303-1690/1) for example. The injector head is still blocked deep inside the seat of the cylinder head and must be removed. Below is a description of this case.

After unscrewing the injector's main body (in the picture to the left, on the engine head **A**) and removing it, screw the M17x0.75 thrust screw (silver) all the way into the injector seat. (Fig. 12+13)

Warning: tighten the screw only slightly to avoid damaging the injector head's fine thread.

Screw in the M18 adapter. (Fig. 14) Screw the thrust screw (black) with the plastic insert into the adapter. (Fig. 15) Now rest the previously mounted cross member against the head's screws with the support feet and insert the screw through the cross member hole.

Insert the thrust bearing into the cross member and screw the pressure nut onto the thrust screw. (Fig. 16)

Act on the nut to remove the injector uniformly. (Fig. 17+18)

Warning: after removal, check that the copper washer is on the injector's extracted head. Otherwise, use the Govoni tool to remove it (GO513).

3) Injector removal with M16x1.5 thrust screw in the event the injector breaks (bottom part) in its seat during the removal with the M17x0.75 thrust screw

In the event that during removal (see paragraph 2 of these instructions) the original M17x0.75 thread was torn off and/or the head's upper part has come off and is hanging from the thrust screw, you must make a new thread in the seat's remaining part that has come off to be able to refit the

12

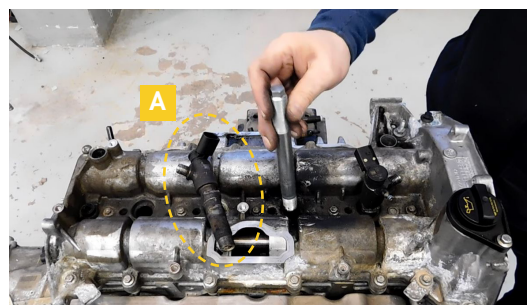

13

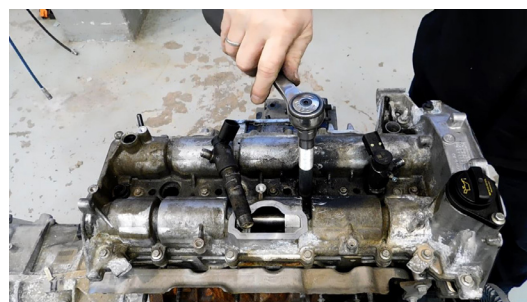

14

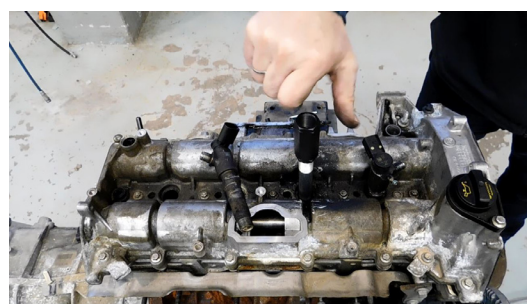

15



16



M16x1.5 thrust screw later on.

Since the head's upper part has come off, you must make the new thread in the head's lower conical part. As such, first of all remove the insert along with all the small parts from the head. Below is the description of the entire procedure.

Use the bar magnet to first remove parts such as the needle, etc. (Fig. 19+20)

After removing all the injector's small parts from the head using the magnet, you must remove the nozzle. Insert the extractor into the injector seat with the expander closed. (Fig. 21)

Warning: the expander should be brought exactly all the way to the bottom. The expander will be opened at the bottom of the injector by blocking the tool's external body and rotating the knurled wheel at the same time. Now you can remove the nozzle **B**. (Fig. 23)

Fit the M16x1.5 male tap into the appropriate handle and fix it using the grub screw. (Fig. 24) Use the hexagonal wrench and the ratchet wrench to make the new thread in the injector head. (Fig. 25)

Warning: in order to maintain a clean and strong thread, pay attention to that specified below. To break the metal shaving, pull out the male tap several times or turn it backwards. It is also advisable to use a suitable cutting oil such as Govoni's Cut+Cool.

Now place the M16x1.5 thrust screw into the injector seat and connect it firmly to the head by screwing it in all the way. (Fig. 26)

Screw the M18 adapter and the M18x1.5 thrust screw with the plastic insert, mount the support cross member with the thrust bearing and the pressure nut. (Fig. 27+28) Act on the nut to remove the rest of the injector head uniformly. (Fig. 29)

The injector is now fully disassembled. (Fig. 30)

17

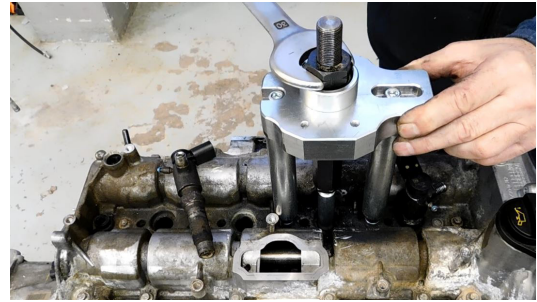

18

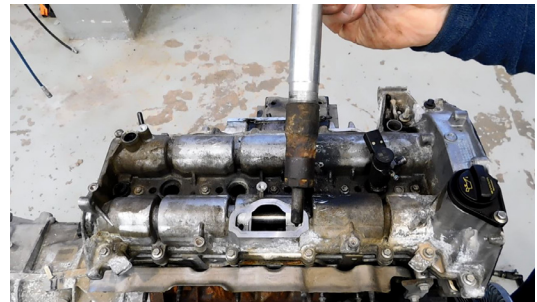

19

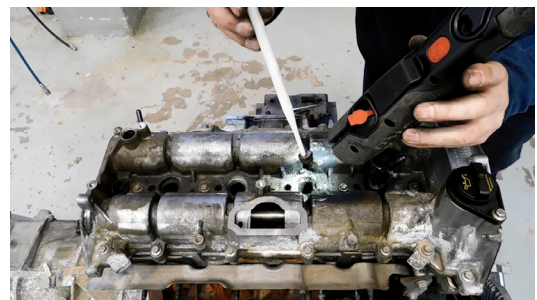

20

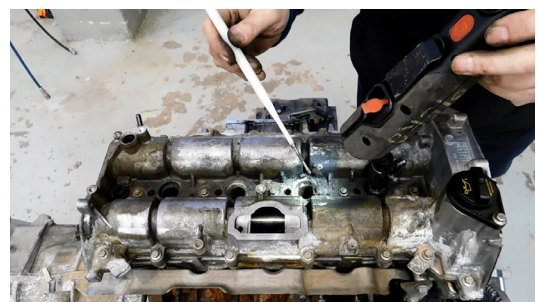

21

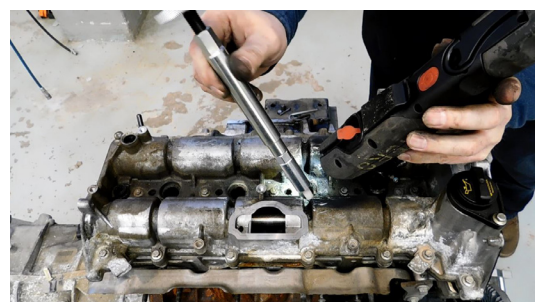

22



23

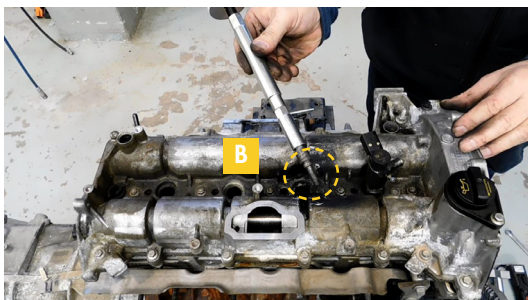

24

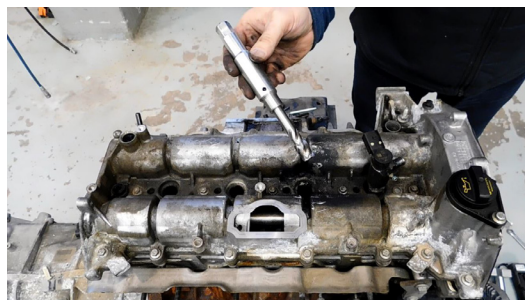

25



26



27



28

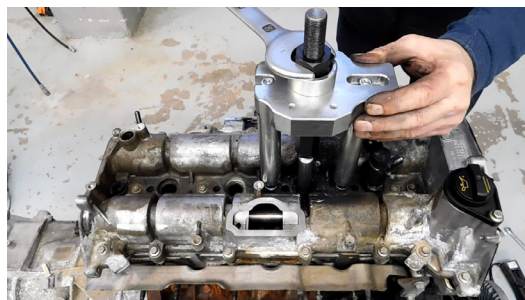

29

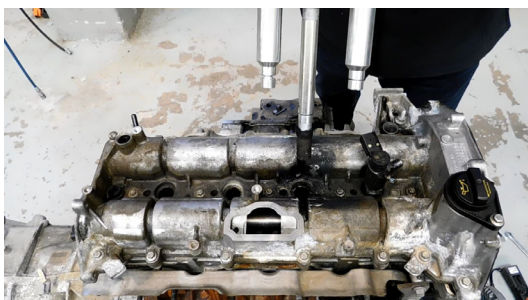

30

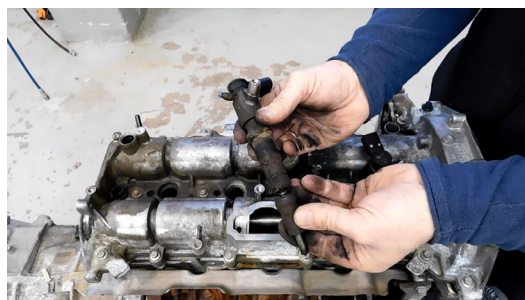



Via degli Orsi, n. 97 | 40014 Loc. Beni Comunali | Crevalcore (BO) Italy
Tel:+39.051.982688 | Tel:+39.051.980798 | Fax:+39.051.6801371
www.govoni.it | **www.thetoolmaker.com** | info@govoni.it