

EN

AIR-OPERATED WASTE OIL DRAINER
Instructions Manual



Mod. 53380000



1. FOREWORD

The warnings and operating instructions must be kept and supplemented by the warnings and operating instructions from the equipment manufacturer. The user must properly train the personnel responsible for operating and maintaining the equipment described in this document.

The manual is an integral part of the equipment and must always accompany it, even if sold.

Before using the equipment, the owner and/or user must be familiar with the operating instructions and recommendations. If operators do not properly understand the language of this manual, the instructions must be read and explained in their own language to make sure that they understand the meaning.

The manufacturer is not liable for any harm to persons or things due to improper or unauthorised use of the equipment

This equipment is for professional use only

2. WARNING

2.1 GENERAL SAFETY

Carefully read the labels on the equipment, do not cover them for any reason and replace them immediately if they are damaged

While operating the equipment, be careful of other persons, particularly children.

- Handling must be performed by trained and authorised personnel using suitable lifting and transportation equipment.
- Do not use the equipment for purposes other than those intended.
- Use the device only for the recovery of waste oil from motorbike, cars, van or truck
- Check equipment every day: check connections, repair or replace worn or damaged parts
- Arrange connecting hoses, away from manoeuvring areas, sharp edges, moving parts and hot surfaces.
- Do not kink or over bend the connection hoses to the equipment.
- The tank, during the emptying phase, must exceed the pressure of 0.5 bar.
- Check that the supply of compressed air provides for the use of effective filtering and pressure reduction systems.
- The storage and working temperature must be between -10°C and $+60^{\circ}\text{C}$
- The humidity must be between 30 and 95%
- In any case the exhaust hose must be not directed at people or animals. It could cause serious injury.
- It is forbidden to carry out welding, grinding and other operations on the equipment. Any unauthorised modification and / or repair work may invalidate the warranty
- Seismic loads not considered to affect the equipment: the installer (or the structure manufacturer) will be responsible for a seismic check on the structure where the equipment will be installed

- Keep away from fire. The user must comply with the applicable fire prevention regulations
- Do not use the equipment in an explosive atmosphere
- Do not use the equipment as a means of transport
- Do not use corrosive solutions that could harm the equipment and/or persons
- Do not knock scaffolding where there is a risk of falling objects
- The equipment can be parked safely on a slope of up to 0.5% before it will slide
- Maintenance must be carried out by suitable qualified personnel under the supervision of personnel appointed by the user.
- Take precautions to prevent harm to persons, the system and the environment. Use suitable personal protective equipment.
- If you encounter abnormal equipment operation, contact the dealer or send the equipment to the nearest service centre.
- If parts need to be replaced, request ORIGINAL spare parts from an agent and/or authorised dealer.
- Comply with the safety and environmental protection regulations in force in the place where the equipment is installed.
- Tampering with any part of the equipment will void the warranty
- Failure to comply with the safety instructions given above will relieve the manufacturer from any contractual liability related to the equipment supply.

This publication may not, in whole or in part, be copied, photocopied, translated without prior consent from Manufacturer. Manufacturer reserves the right to modify the equipment in order to improve its technical characteristics and to revise this publication or to change its contents without notice. Information contained herein is for reference only and does not constitute a commitment on the part of the Manufacturer.

3. LOADING, UNLOADING AND TRANSPORT

On receipt of the machines, make sure that they have not been damaged during transportation and that the packaging has not been tampered with, allowing the contents to be removed from the package.

Immediately inform the carrier and the manufacturer of any damage or missing parts, and provide photographic documentation.

N.B.: We recommend checking that the supply corresponds with the order specifications

4. FEATURES

Pneumatic equipment for fast recovery of engine oil from any vehicles.

The oil change take place by gravity, or by extraction from the engine sump, with hot oil (70° C) through one of the 6 included probes.

4.1 TECHNICAL SPECIFICATIONS

- Painted reservoir, carbon steel made
- Brain Bowl capacity: 18 l
- Drain bowl with drain filter grid.

Sizes : A: mm. 540
 B: mm. 620
 C: mm. 1250
 C1: mm. 580

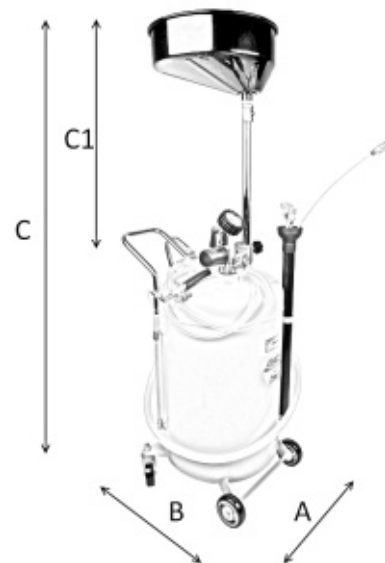

4.2 COMPOSITION OF EQUIPMENT

- 1) DRAINING BOWL
- 2) DRAINING BOWL TUBE
- 3) HANDLE
- 4) CASTER WHEELS
- 5) FIXED WHEELS
- 6) DISCHARGING HOSE
- 7) RESERVOIR
- 8) PROBE HOLDER
- 9) EXTRACTION PROBES
- 10) VACUUM UNIT

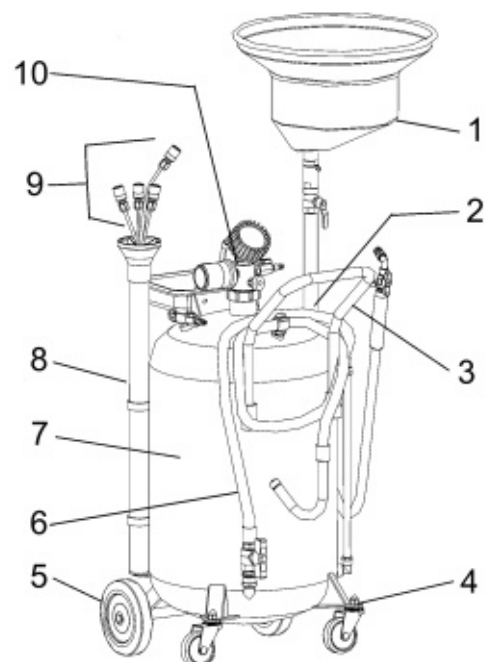

5. INSTALLATION

1. Place the swivel wheels (4) on the brackets, tighten the nuts and bolts
2. Place the fixed wheels (5) on the axis, fix well with the hardware supplied
3. Connect the extraction unit (10) to the tank (7), making sure that the gasket is correctly positioned. With a suitable wrench, tighten the ring nut
4. Insert the draining bowl tube (2) into the tank fitting and screw tight
5. Connect the draining bowl (1) to the draining bowl tube (2) and tighten securely
6. Screw the drain hose fitting (6) to the ball valve
7. Connect the handle (3) in the appropriate seats and fix it with the supplied screws
8. Position the probe holder (8) and the probe set (9) in its housing

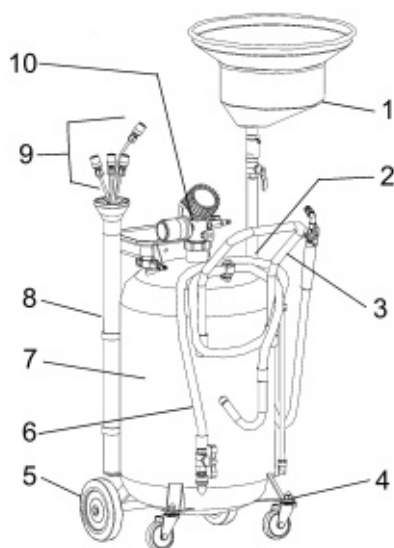

Ref. 5.5

Pay attention to the side of ring nut (A).
Connect as shown in the picture

6. INSTRUCTIONS FOR USE

6.1 EXTRACTION WITH DRAIN BOWL

6.1.1 Close the ball valve B, A, F.

6.1.2 Place the equipment under the vehicle at the drain plug;

6.1.3 Adjust the drain bowl at a distance of about 20 cm from the drain plug;

6.1.4 Open the ball valve Q and open the vehicle drain plug. The oil will be collect into the tank

6.1.5 At the end of the operations close the ball valve Q

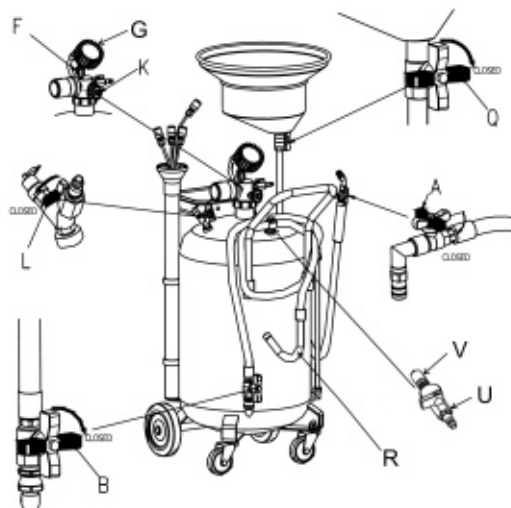

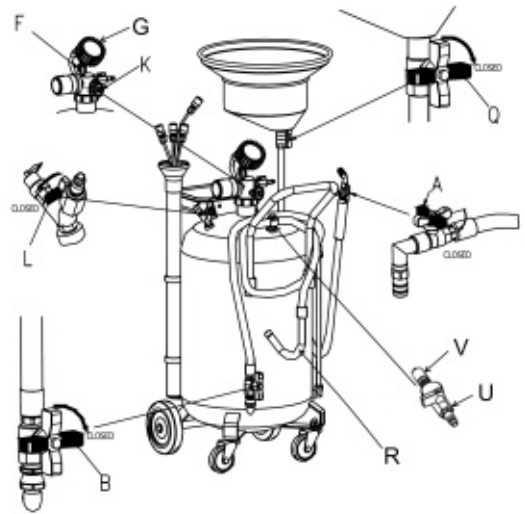

6.2 EXTRACTOR WITH DRAINING PROBES

6.2.1 Fully open the K valve by turning it clockwise. Close ball valves A - B - L - Q

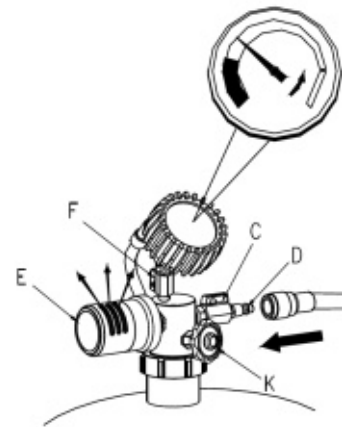

6.2.2 Connect the compressed air at 100 psi (7 bar) to the quick coupling D. Open the ball valve C and F. The air comes out from the muffler E. When the vacuum gauge arrow approaches the red zone, (2-3 min), closes the ball valve C and disconnect the compressed air. Now the unit is depressurized and ready for use



 We recommend using a compressor with a capacity of at least 200 l / min

6.2.3 Switch the vehicle off for maintenance and engine from the engine oil dipstick

 The engine oil must be warm, at a temperature of about 70 °C.

6.2.4 Between the probes supplied with the appropriate diameter, insert it in depth, into the housing of the level casing, and connect it to the union A. open the ball valve A, the oil will flow into the tank.

 Some vehicles are equipped with a built-in extraction probe, in this case, connect the fitting "A" to one of the supplied adapters and use it instead of the flexible probes

6.2.5 When the oil is completely drawn in, close the ball valve A

 Never fill the tank beyond the maximum limit given by the level indicator



6.3 EMPTYING THE TANK

6.3.1. Make sure that the ball valve F and the handwheel K are closed.

6.3.2. Make sure that the ball valve Q and ball valve B are closed.

6.3.3 Connect the compressed air hose to the quick connection L and adjust, with a suitable pressure reducer (not included), the continuous pressure of 0.5 bar.

 The equipment is provided with a safety valve against overpressure

6.3.4. Hook the drain hose R to the storage container (not included) and open the ball valve B. Drain the tank completely from the used oil

6.3.5. When the operation is complete, close the ball valve B and place the drain pipe R on the equipment

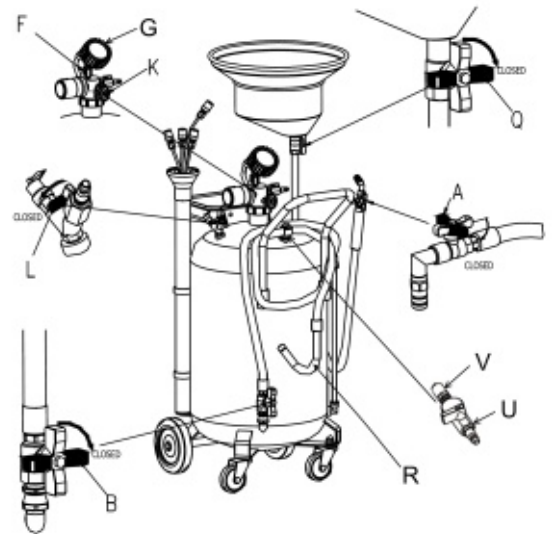

7. MAINTENANCE AND CARE

Periodically check (at least every month), that the vacuum gauge (G) and the safety valve (V) are not damaged and are functioning correctly; replace them if necessary.

Replace the transparent level tube when the indication is no longer clear

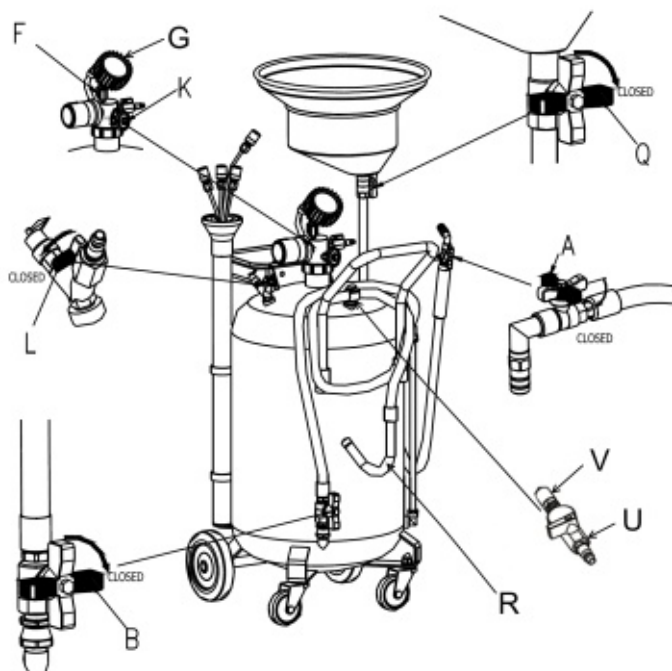

8. PROBLEMS CAUSES SOLUTIONS

PROBLEMS	CAUSES	SOLUTIONS
Turn on the air source, the vacuum gauge (G) index doesn't move	Damage or jam on the vacuum gauge	Change the vacuum gauge
	The valve (K) is closed	Open the K valve by turning the handwheel counterclockwise
The index on vacuum gauge (G) can't reach the green area	Air supply pressure is too low	Increase the air supply pressure
	Air flow in not enough	Make sure that the compressor has a tank capacity of at least 200 litres
The vacuum gauge (G) index reaches the green area, but no extraction of oil occurs	Oil temperature is too low	Increase the oil temperature (eg. Start the engine)
	There is a jam in valve of the extraction hose	Clean up the valve

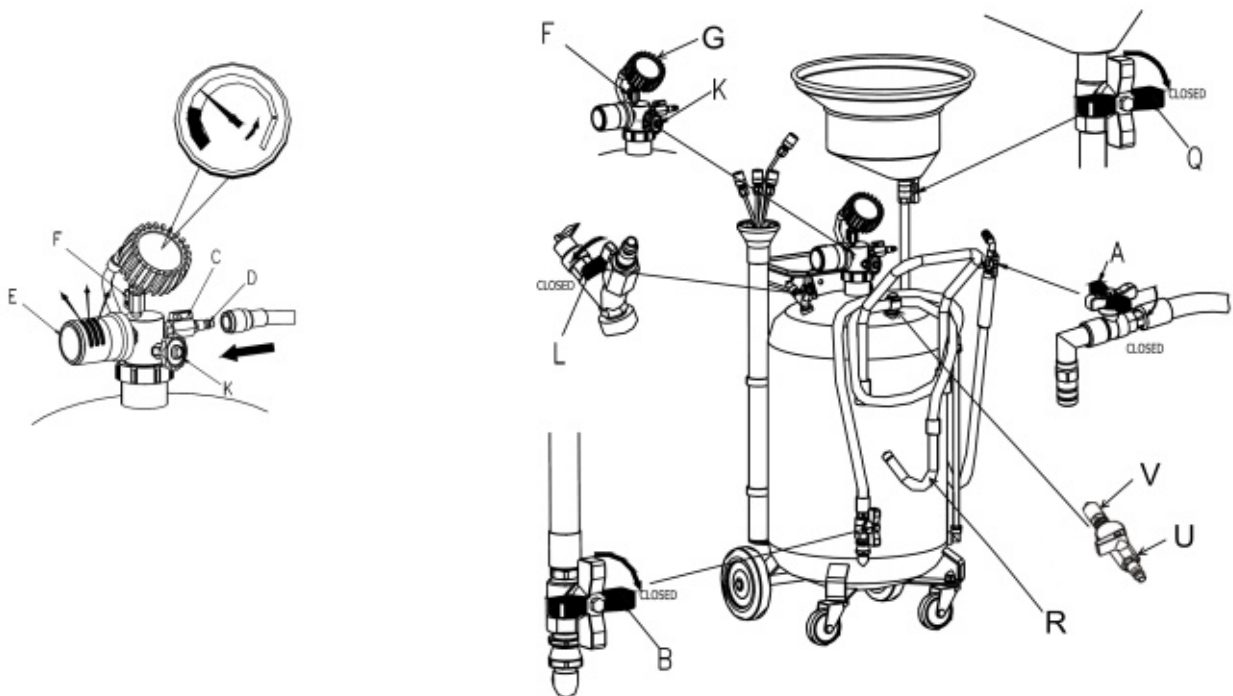

9. PARTS LIST AND EXPLODED VIEW

Pos	Description	Q.ty
1	BOLT	2
2	WHEEL	2
3	TANK	1
4	SWIVEL WHEEL	2
5	WASHER	2
6	NUT	2
7	ELBOW	2
8	RING	2
9	TUBE	1
10	BALL VALVE	1
11	DISCHARGING HOSE	1
12	VALVE BODY	1
13	O-RING	1
14	O-RING	1
15	STEEL BALL	1
16	SPRING LOCK WASHER	1
17	SCREW	1
18	O-RING	1
19	SHAFT	1
20	O-RING	1
21	VALVE BODY	1
22	O-RING	1
23	BOLT	1
24	O-RING	1
25	KNOB	1
26	VALVE PLUG	1
27	O-RING	1
28	BALL VALVE	1
29	MUZZLE	1
30	VALVE	1
31	GAUGE	1
32	GAUGE RUBBER OUTER	1
33	Y-ELBOW ADAPTOR	1
34	ELBOW ADAPTOR	1

Pos	Description	Q.ty
35	NUT	1
36	VALVE SEAT	1
37	COMPLETE MUFFLER	1
38	PROBE CONTAINER	1
39	VALVE	1
40	BALL VALVE	1
41	PLUG	1
42	EXTRACTION HOSE, COMPLETE	1
43	PROTECTOR, SUCTION HOSE	2
44	BALL VALVE	1
45	ELBOW ADAPTOR	1
46	LINK	1
47	O-RING	2
48	FLEXIBLE PROBE 5x700	1
49	FLEXIBLE PROBE 6x700	1
50	FLEXIBLE PROBE 7x1000	1
51	FLEXIBLE PROBE 8x700	1
52	MALLEABLE PROBE 5x700	1
53	MALLEABLE PROBE 6x700	1
54	CONNECTOR (VW)	1
55	O-RING	2
56	CONNECTOR (BMW)	1
57	O-RING	1
58	SPRING LOCK WASHER	1
59	O-RING	1
60	KNOB	1
61	SEAT	1
62	O-RING	2
63	ADJUSTABLE STEEL TUBE	1
64	BALL VALVE	1
65	ROTOR	1
66	O-RING	2
67	OIL COLLECTION BOWL	1
68	NUT	1
69	PLASTIC FILTER	1

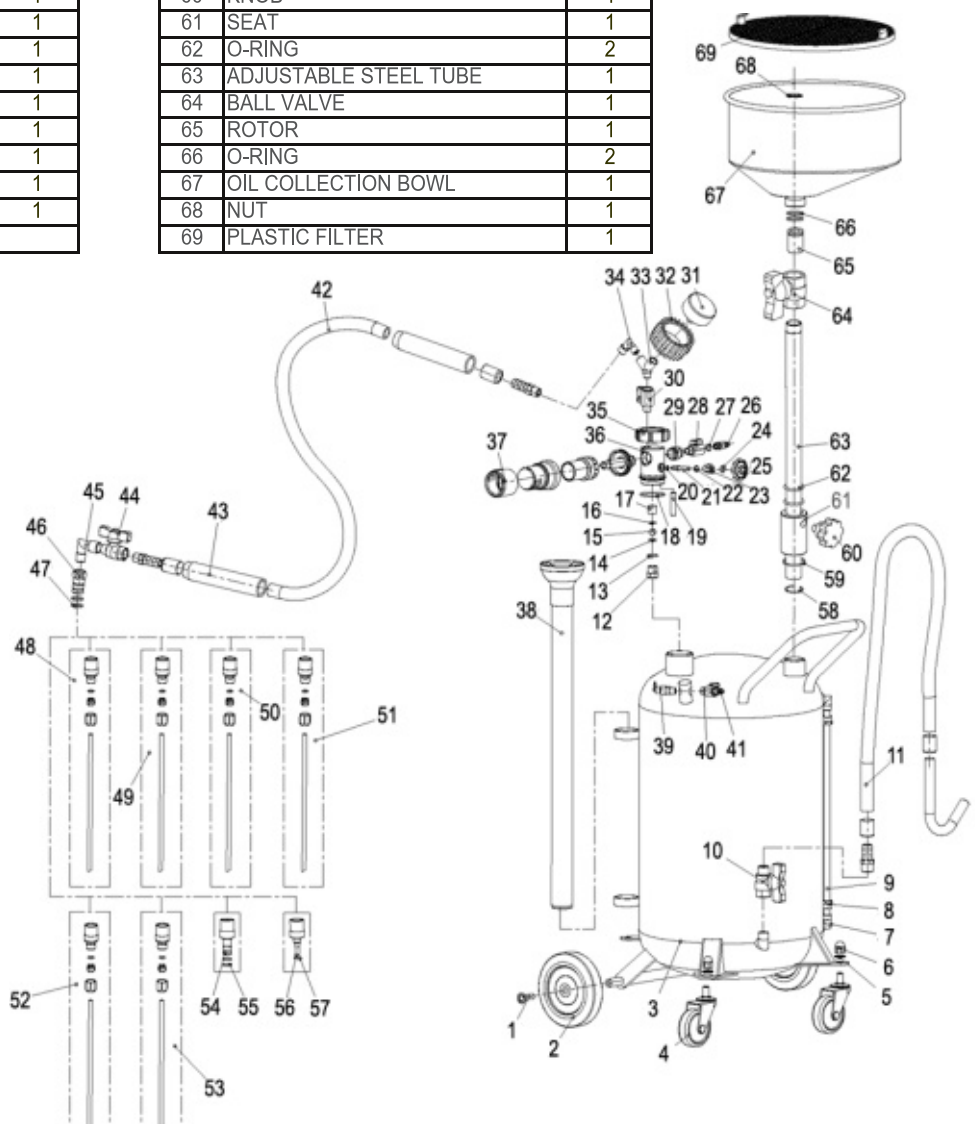

10. STORAGE, DISMANTLING AND DISPOSAL

If the equipment must be stored for a long time, leave it where it is sheltered from the wind and rain, and ideally in a dry place.

The equipment may suffer serious damage if it is kept in an environment at a critical temperature while waiting for installation.

10.1 Environmental protection

Recycle unwanted materials rather than disposing of them as waste. All tools, accessories and packaging must be taken to a recycling centre and disposed of in an environmentally friendly manner

11. WARRANTY TERMS

Unless otherwise agreed in writing, the warranty covers a period of 12 months from the delivery date.

For parts not made at the manufacturer's sites, the warranty is limited to that provided by the supplier.

During the warranty period, all parts with material or manufacturing defects will be replaced free of charge, at the sole discretion of our Technical Department.

Investigation into the defects and their causes must be carried out at our site.

The buyer shall bear the costs for any on-site inspections carried out by manufacturer, for transport and packing of the parts to be repaired or replaced and the labour for installing them.

Repairs or replacements carried out with non-original parts will void the warranty, as will any work not described in the manual and carried out without our authorisation.

The warranty does not cover parts that, due to their nature or use, or due to poor maintenance, are subject to wear and tear.

Under no circumstances can the buyer claim compensation for damages of any nature regardless of how they arise.

On delivery, the customer must check that the machine meets the contractual requirements and has not been damaged during transport. Otherwise, the customer must not use the machine and must inform the manufacturer or supplier within 7 days

NOTE: All the information in the following document is based on the data available at the time of printing. The manufacturer reserves the right to change its products at any time without prior notice and without any penalty. We therefore recommend that you always check the availability of further update

