



GM Gearbox Bearing / Race Remover

08550300

Designed for the removal of large taper bearing races situated in the gearbox housing.

The tool enables the races to be removed in a controlled straight manner whilst spreading the load equally around the bearing housing so as to prevent the housing from cracking.

This tool is for M32, MT 20-6, MT 32-6 F40 gearboxes as commonly found on GM, Saab and Fiat vehicles.

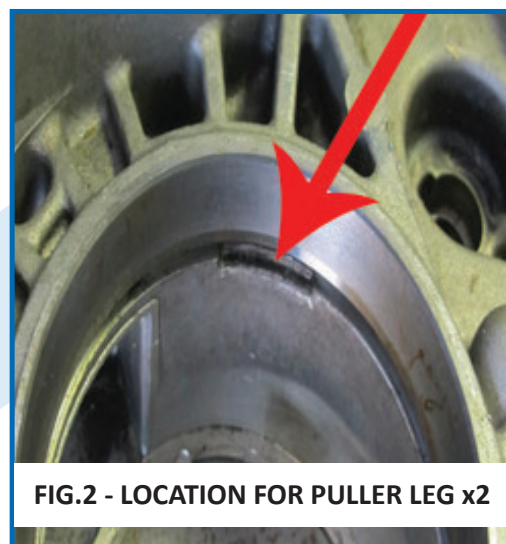
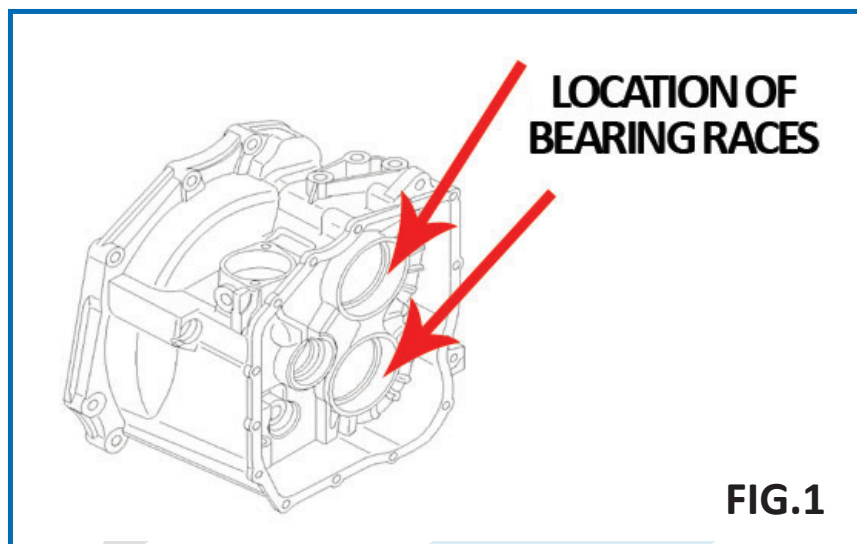

INSTRUCTIONS

1. Insert puller and engage legs into the two slots under the bearing races (See Fig 1, 2 and 3 for location)
2. Place the pulling sleeve over the puller and clear of the race to be pulled (Fig.4)
3. Insert force plate between puller force screw and sleeve ensuring dimple faces upwards for screw to centralise (Fig.5)
4. Turn force screw with spanner to remove bearing race.

(ENSURE FORCE SCREW IS LUBRICATED WITH GENERAL PURPOSE GREASE / OIL)

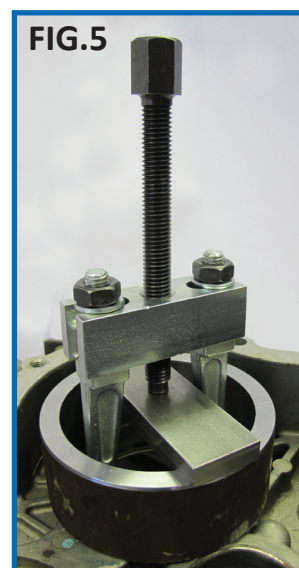
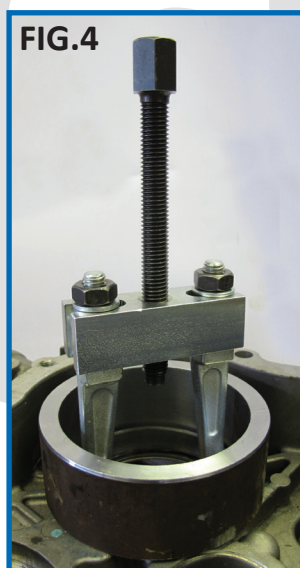
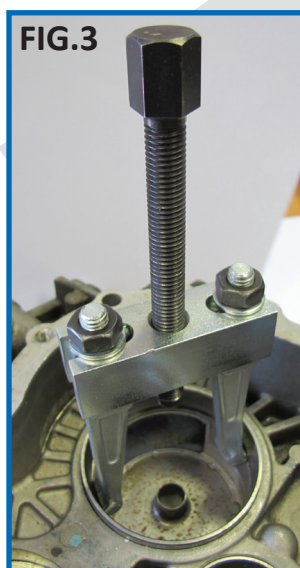



GM Gearbox Bearing / Race Remover 08550300

CONTENTS

Part No	Description
08271100	Force Screw - Finished
085503-01	Beam
085503-02	Leg Assembly x2
085503-03	Force Plate
085503-04	Pulling Sleeve

APPLICATIONS

Astra-H 2004 (2004-2009)

Astra-J (2010-)

Corsa-D (2007-)

Meriva (2003-2010)

Meriva-B (2010-)

SIGNUM (2003-2008)

Vectra-C (2003-2008)

Zafira-B (2005-2010)

Punto 1.9JTD (1999-)

Alfa Romeo 159 2.0JTDM (2009-)

Also commonly used on Alfa Romeo, Fiat, Chevrolet and Vauxhall Opel models