

CAUTION: Do not allow halfshafts to hang unsupported at one end or joint damage will occur.

CAUTION: Do not use a hammer to detach the halfshaft from the hub assembly, failure to follow this instruction may result in damage to the halfshaft.

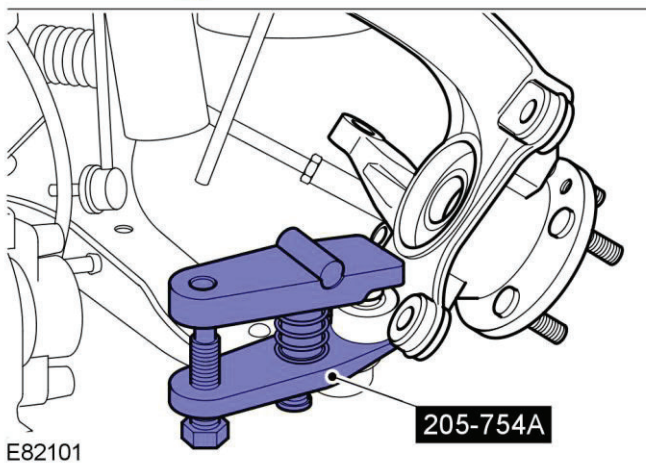
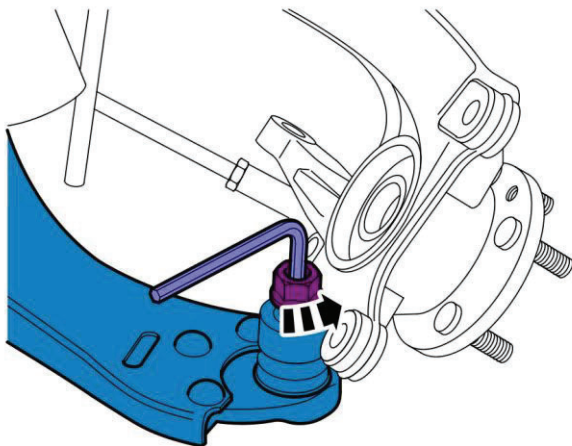

E82101

WARNING: Make sure that a new lower arm ball joint nut is installed.

CAUTION: Make sure that the ball joint ball does not rotate.

Special Service Tool

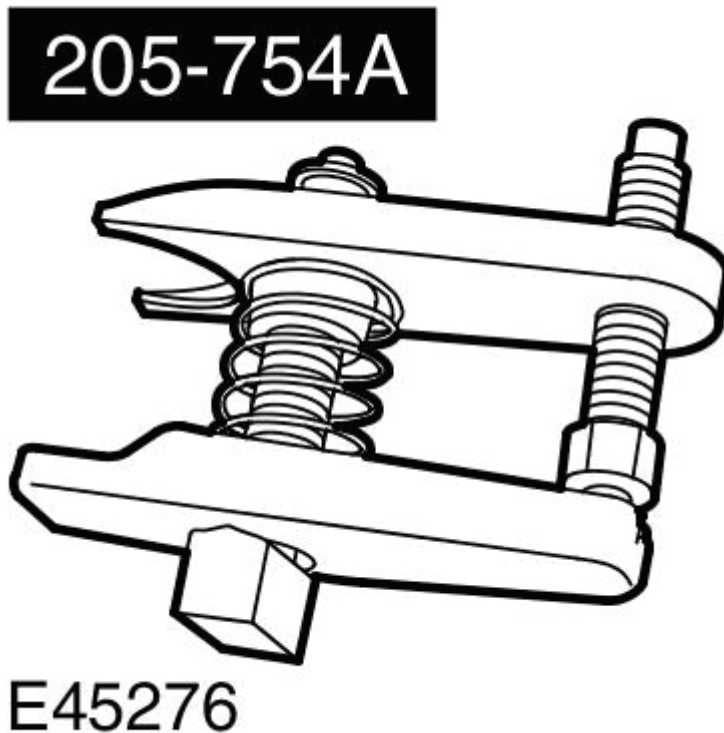

Splitter, Ball Joint, 205-754A

Torque to: 100 Nm

Installation

CAUTION: Make sure that the brake hose is not twisted and is correctly located.

CAUTION: Nuts and bolts must be tightened with the weight of the vehicle on the suspension.

CAUTION: Install the halfshaft bolt finger tight.

NOTE:

Make sure that all the component mating faces are clean.

- 1 To install, reverse the removal procedure.