



BOWPELLER®



MODEL B3258

Thank you for purchasing BOWPELLER®;
the low shear, gentle product handling, centrifugal pump!

This manual contains installation, operation, cleaning and repair instructions with
parts lists, for Bowpeller® centrifugal pump by:



8920 58th Place, Suite 100, Kenosha, WI 53144
(262)-909-0013





IMPORTANT SAFETY INFORMATION

Safety is very important!

DO NOT attempt to modify any Bowpeller® product. To do so could create unsafe conditions and void all warranties.

DO NOT place any Bowpeller® product in an application where general product service ratings are exceeded.

The following **DANGER**, **WARNING**, AND **CAUTION** signs and their meanings are used within these instructions.

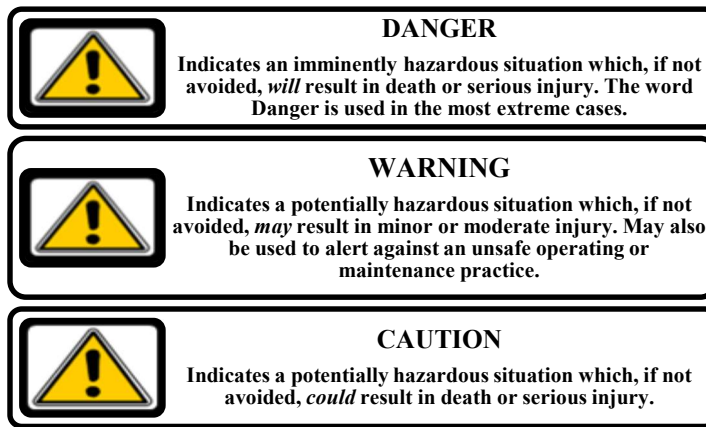

Safety labels are placed on every Bowpeller® product. Do not remove any labeling on any Bowpeller® product. Immediately replace any label that is missing.

DESCRIPTION

The BOWPELLER® series close coupled pumps are made up of two sections: The power or drive section and the liquid end or pump section.

The pump is mounted to the frame of the drive motor by means of an adapter and is coupled to the motor shaft by a stainless steel stub shaft. The impeller threads directly onto the stub shaft and is sealed with an o-ring. The casing is clamped to the adapter, greatly simplifying removal, and also permitting positioning of the discharge outlet through 360°. The external, balanced seal assures long seal life. The drive motor is available with a frame having adjustable legs providing simple installation and leveling.



WARNING

Before servicing pump, disconnect electrical power source.

INSTALLATION GUIDELINES

UNPACKING EQUIPMENT

Check the contents and all wrapping when unpacking your equipment. Inspect all parts for damage that may have occurred during shipping. Report any damage to the carrier.

LOCATION AND INSTALLATION

The pump unit should be located as near as possible to the liquid source and in a position where the suction piping can be short and direct with a minimum number of elbows and fittings. It should also be readily accessible for inspection and cleaning. The pump unit as received from the factory is ready for installation. To install it, attach a hoist if necessary, loosen the setscrews in the adjusting leg brackets, (if provided) and individually adjust the legs until the pump unit is level. Tighten the setscrews. Attach the suction and discharge piping. Be sure suction and discharge piping is properly supported to avoid any strain on the pump casing.

PIPING HINTS

GENERAL

This section provides some do's and don't's of piping which will aid in obtaining the maximum efficiency and service from your pump. Piping should be independently supported at both the suction inlet and discharge outlet. Care should be taken that piping is properly aligned and does not put any strain on the pump casing. The piping should have as few bends as possible.

SUCTION PIPING

The suction piping should be short and follow a direct route with a minimum number of elbows and fittings. Elbows should be located as far as possible from the pump inlet. Whenever practical the diameter of the piping at the suction inlet should be increased in size. An eccentric tapered reducer should be used in lieu of a concentric tapered reducer to prevent air pockets from forming and impairing pump efficiency. The eccentric reducer may be placed at the inlet of the pump and should be positioned so the straight side is up. A horizontal suction pipe must have a gradual rise to the pump. A high point in the suction line will form an air pocket and prevent proper pump operation. All joints in the suction line should be air tight, to prevent air leakage which can reduce pump capacity and efficiency.

DISCHARGE PIPING

Position of the pump discharge is preferably either vertical or top horizontal. The discharge piping should be short and direct with a minimum number of elbows and fittings. Elbows should not be used at the discharge outlet.

ELECTRICAL INSTALLATION

We use standard duty motors unless otherwise specified. Many motor options are available: wash down, flameproof, explosion proof, hostile duty or chemical duty. The motor selected should meet the requirements of the specified operating conditions. A change in conditions (for example, higher viscosity, higher specific gravity, lower head losses) can overload the motor. When changing operating conditions or whenever there is any doubt, please contact us for technical assistance.

Have an electrician connect the motor using sound electrical practices. Provide adequate protection. Pumps fitted with mechanical seals must not run dry. Determine the direction of rotation by watching the motor fan, which must turn clockwise.



START-UP INSTRUCTIONS

- Remove any foreign matter that may have entered the pump.
- Do not use the pump to flush the system!
- Briefly check pump for proper rotation as indicated on the pump. Proper motor direction is clockwise when looking at the fan end of the motor. (NOTE: When checking the direction of rotation, the pump must not be full of liquid.)
- Never run the pump dry. Seal damage can result.

WARNING

Do not allow any objects near the ports, shaft, or fan cover while the motor is turning.

MAINTENANCE DISASSEMBLY, CLEANING (GENERAL)

WARNING

Before servicing pump, disconnect electrical power source, carefully relieve all pressure and drain all fluids from pump and connected piping.

CAUTION: Before Attempting Repair please view our **Bowpeller® Pump Assembly Video** at:
<https://youtu.be/MhpblNGXvY8>



REPAIR

It is recommended that periodic inspection of all parts of the pump be made to prevent malfunctions caused by worn or broken parts. Disassembly for repair is the same procedure as for cleaning.

Note: Protect the sealing surface against nicks and scratches while removing, cleaning and reassembling.

For BOWPELLER® pumps it is not necessary to disassemble if used in Clean-In-Place installation and the CIP process is completed prior to any drying of residual product. Should the residual product solidify, the pump must be disassembled for cleaning.

1. To disassemble, disconnect the suction and discharge piping. Loosen the wing nut on the clamp assembly until tension on the clamp saddle is relieved. Open the clamp and remove the casing.
Use a flat screwdriver to lock stub shaft in place and a mallet to tap impeller in **counter clockwise** direction, then thread impeller off of stub shaft.
2. Remove the shaft O ring.
3. Rotate the backplate **counter clockwise** until the backplate bolt retainers clear the grooves in the adapter and remove the backplate.

CAUTION: The seal spring will push the back plate forward when free of the retaining studs.

4. Examine the backplate sealing surface carefully for any defects that will shorten seal life.
Do not remove stub shaft from motor.
5. Remove and inspect the impeller/shaft o-ring for cuts or damage and replace as required. In the event that the impeller/shaft o-ring does fail, the impeller and shaft threads must be thoroughly cleaned and all traces of product removed prior to reassembly.
6. Remove and inspect casing clamp for damage or wear and replace as required. Inspect the adjusting legs, adjusting leg brackets, adapter and casing and replace if necessary. Motor maintenance, repair and wiring are not covered in this manual. For specific information contact the motor manufacturer.



- Remove and carefully inspect the o-ring seal and carbon seal for signs of abrasions, cuts or other wear that would cause leakage. In the event that the carbon seal or seal o-ring does fail, the spring, collar and stub shaft must be thoroughly cleaned, and all traces of product removed prior to reassembly.

** Please view our **Bowpeller® Video** at:
<https://youtube.com/watch?v=ZofXmCksreI>



ASSEMBLY

- Slide the stub shaft onto the motor armature shaft and ensure it is bottomed out on motor shaft. Using a torque wrench tighten the shaft collar screws to 22 ft/lb (only if changing out motors; never remove stub shaft for routine maintenance)
- Install the adapter to the motor. (Ensure the motor C-Face is clean.) Insert the four bolts securing the adapter to the motor. Tighten the bolts securely.
- Slide the mechanical seal collar, spring, cup and carbon with O-ring; onto the stub shaft. Water may be utilized as lubricant.

Note: Do not lubricate the seal faces, they are lubricated by the product.

- Install the stationary seal into back plate. Lubricate with water, if required. Install backplate onto pump by aligning backplate screws with grooves and rotating the backplate clockwise until the bolts in the backplate engage the grooves and lock the backplate into the adapter bracket.
- Install O-ring on backplate.
- Replace impeller shaft O-ring and thread the impeller on the shaft (**clockwise to tighten**).
- When the impeller is hand tight, lock the stub shaft by placing a flat screwdriver into stub shaft groove and through adapter slot. Tap impeller with rubber mallet to ensure tightness.
- Place the casing in position. Align the clamp to the adapter and casing, close and tighten the clamp
- Assemble the suction and discharge piping to the pump. Check for strain on the casing. Adjust as necessary.

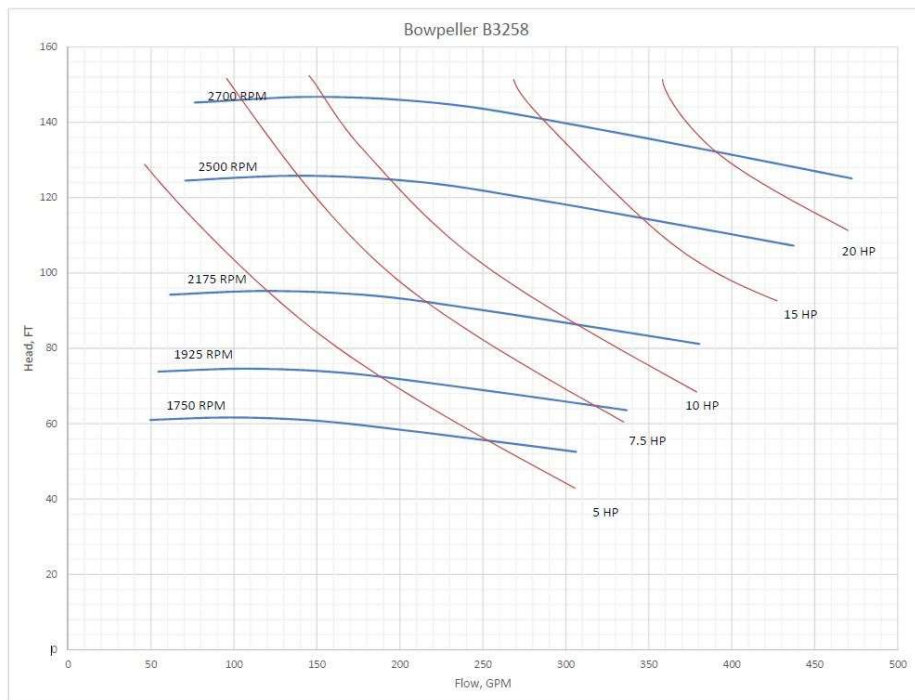

BOWPELLER®

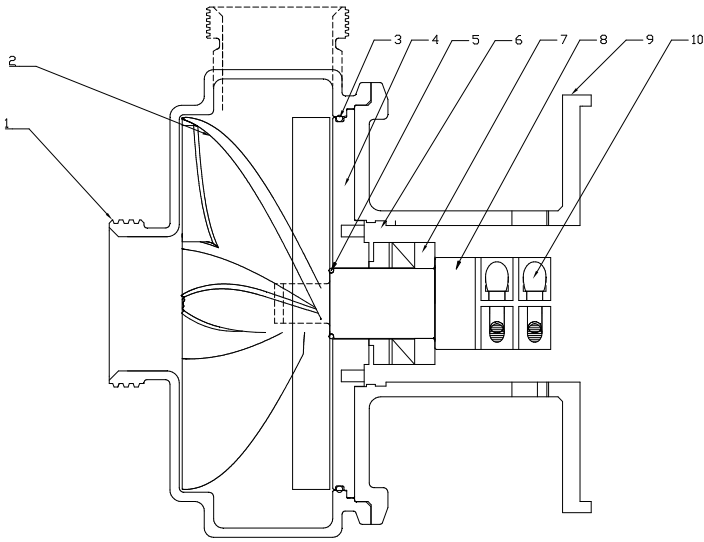

Parts List		
Key	Part #	Description
1	B3258-001-304-B	3" X 2.5" bevel seat Casing
2	B3258-002-304	Bowpeller®
3	B3258-090-EPM	Casing O-ring
4	B3258-011-304	Back Plate
5	B3258-100-EPM	Impeller O-ring
6	US21937-1000	Back Plate Screw
7	B3258-080-ASY	Mechanical Seal Assembly
8	B3258-006-304-180	Stub Shaft
9	B3258-71-304-180	Frame Adapter
10	B3258-06A-303	Shaft Compression Bolts

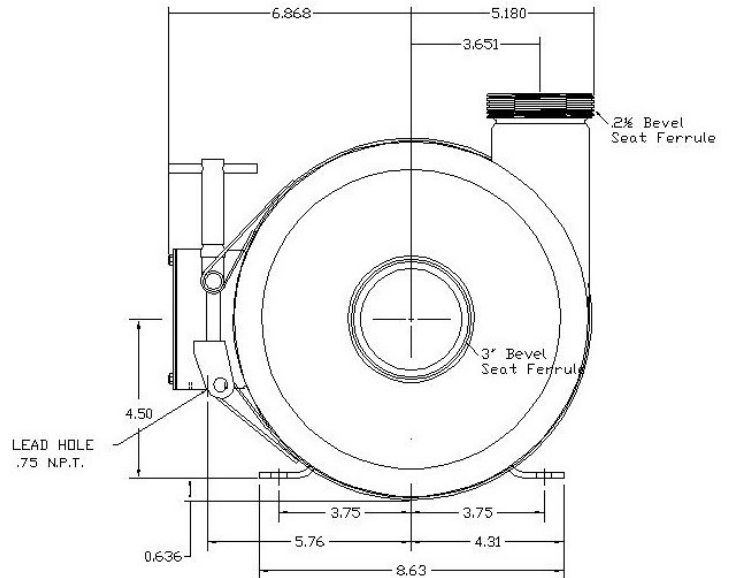
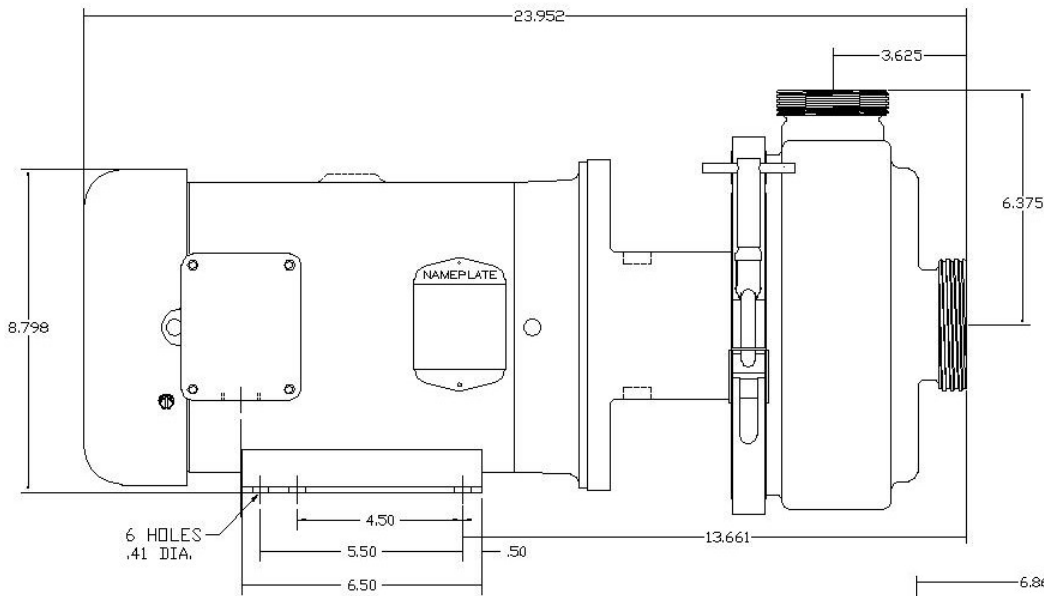

BOWPELLER®

*Bowpeller® - Model B3258, low shear, pump.
Mechanical seal changeout*

Complete Rotating Seal Assembly



1

O-ring
Carbon rotating face
(w/ O-ring)
Seal Cup
Spring
Collar



1a

Ensure stub shaft is bottomed completely on motor shaft and torqued.

Place the complete rotating seal assembly on stub shaft.

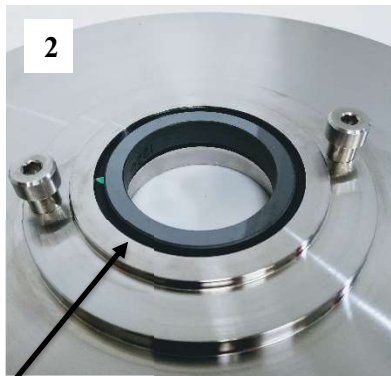

2

Stationary silicon carbide seal in Viton cup

(Press in / out by hand)

Align backplate pins with Grooves in Adapter

Press backplate down gently and lock in place by rotating backplate clockwise



3



4

Place O-ring on shaft and thread on impeller



8920 58th Place, Suite 100, Kenosha, WI 53144
(262)-818-1381 or (262)-909-7267