

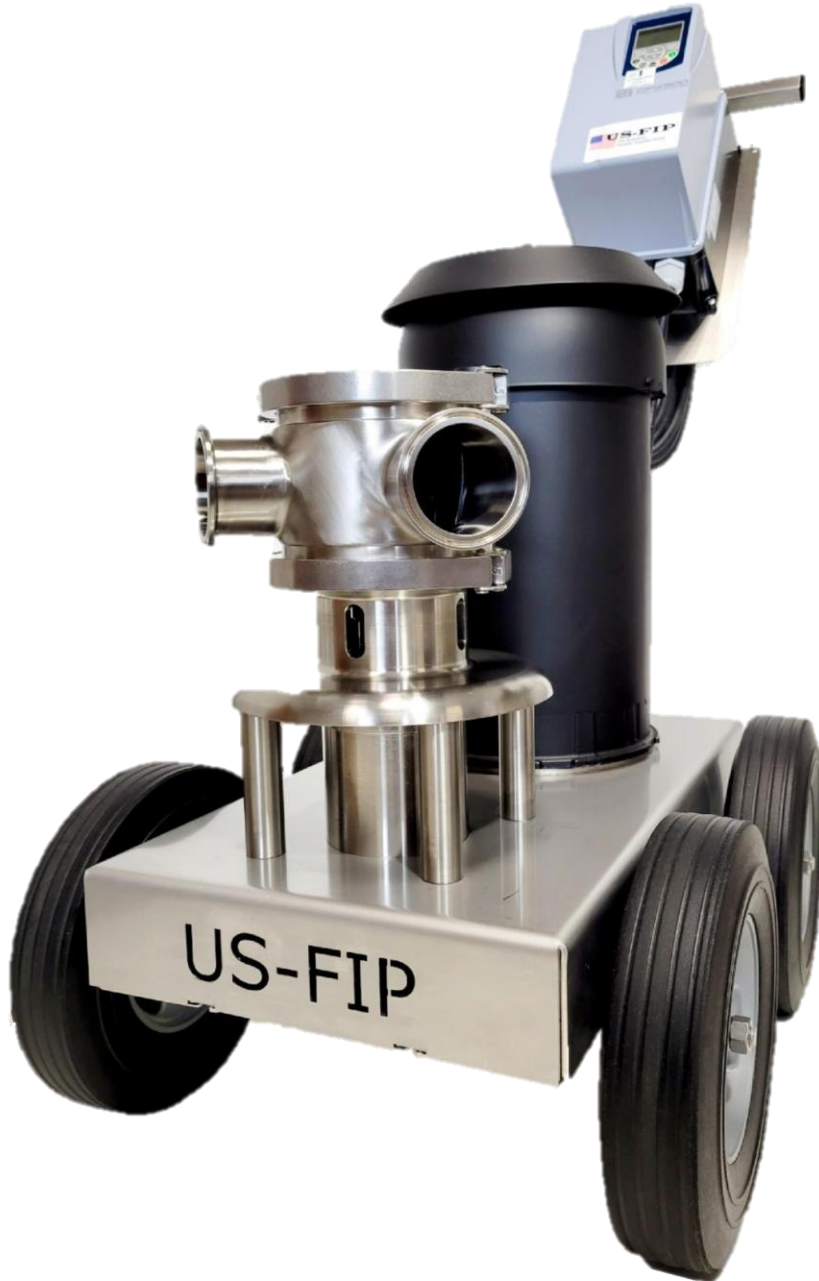

## Model 22060 2 1/2" Pump Cart Manual



8920 58<sup>th</sup> Place, Suite 100, Kenosha, WI 53144  
(262)-909-0013



## Thank you for purchasing a US-FIP product!

This manual contains installation, operation, cleaning and repair instructions, with parts lists, for your US-FIP Pump & Cart system.

**READ THIS MANUAL** carefully to learn how to service the US-FIP Pump & Cart system. Failure to do so could result in personal injury or equipment damage.

**SAFETY:** *Safety is very important!*

**DO NOT attempt to modify any US-FIP product.** To do so could create unsafe conditions and void all warranties.

**DO NOT place any US-FIP product in an application where general product service ratings are exceeded.**

The following DANGER, WARNING, AND CAUTION signs and their meanings are used within these instructions.

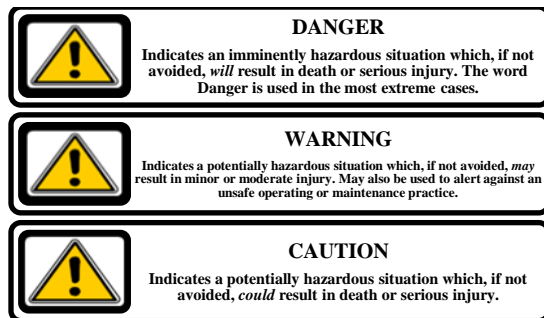

Safety labels are placed on every US-FIP product. Do not remove any labeling on any US-FIP product. Immediately replace any label that is missing.

## RECEIVING EQUIPMENT

When unpacking your equipment, inspect all of the contents for damage that may have occurred during shipping. Report any damage to us immediately.

## FLUID CONTACT MATERIALS

304 Stainless Steel, EPDM, Carbon Graphite

**Installation** – Your US-FIP Pump head may be rotated to any position. The rotation of your US-FIP Pump shaft determines the inlet and outlet ports (refer to the dimensional drawing).

The pump is normally assembled at the factory for clockwise rotation when looking at the front. If counterclockwise rotation is required, your US-FIP pump has reverse capability on the variable frequency drive that is facilitated by your remote transmitter.

## OPERATING INSTRUCTIONS



### Proper Impeller Care

- \* Do not run dry
- \* Use 10' suction hose of the same diameter as the pump connection or larger.
- \* If the pump makes a "ticking" noise, **SLOW DOWN!** - Your impeller is suffering
- \* **Rinse your pump thoroughly with water**
- \* Never leave anything in the pump besides water
- \* **Use only Food Grade Silicone Lubricant \***

Use **ONLY** food grade silicone lubricants

Any questions please call (262)-909-0013

**Drive** – Your US-FIP Pump is arranged with belt-drive operation. Care should be taken not to over tighten the belt as this will reduce bearing life.

If a pulley must be pressed onto the pump shaft, remove the front cover and impeller and support the shaft from the impeller end. Do not hammer pulleys onto the shaft; this may damage bearings or seals.

**Speeds** –For longer pump life, operate at the lowest possible speed. Low speeds are also required for viscous fluids.

**Self-Priming** – Your US-FIP Pump is capable of priming at low or high speed. For vertical dry lifts of 10 feet, a minimum of 30 HZ is required.

The pump will lift up to 22 feet when wet. The suction lines must be air tight for self-priming

**WARNING**

Relieve pressure and remove all fluid from the US-FIP pump prior to disassembly.

**WARNING**

Remove power prior to servicing to prevent unintended start of the pump.

operations and must be greater than or equal to the pump port size and less than 10ft long.

**Running Dry** – This pump relies on the pumped fluid for impeller and seal lubrication. Do not run dry for more than 30 seconds. Running the pump without liquid will damage the impeller.

Use **ONLY** food grade silicone lubricants

**Compatibility** – Neutralize all corrosive cleaning solutions after each use or at the end of each day to prolong pump life. Leave nothing in the pump other than water.

**Temperatures** – The operating temperature range of this pump is 40° to 180° F (7° to 80° C). Temperatures up to 210° F are achievable with a Hi-temp impeller.

**Cleaning** – All parts have been expertly manufactured and polished—handle all parts with care.

If acidic cleaners are used, be sure to rinse the pump thoroughly after each application.

**NOTE: The US-FIP is not designed for clean-in-place operations and must be disassembled for proper cleaning.**

**Impeller Torque** – The torque required to initiate rotation of a new impeller in a dry pump body is:

Forward: 10.2 pounds force – feet

Reverse: 18.8 pounds force – feet

These values may vary slightly due to manufacturing tolerances.

**Spare Parts** – To avoid costly downtime, keep a spare US-FIP impeller, seal kit and o-rings on hand.

## SERVICE INSTRUCTIONS

### GENERAL

The US-FIP Pump & Cart is relatively maintenance free, requiring normal cleaning and

inspection to ensure optimum performance. Inspect the impeller and all seals for cuts or abrasions and inspect seal faces for nicks and cracks. Replace worn or damaged parts as necessary.

### REPAIR INFORMATION

Repair of the US-FIP Pump & Cart system is normally accomplished by replacing defective parts. The only moving parts are the impeller, the pump and motor shafts, the seal, and the belts. For repair or replacement of the drive motor, refer to the motor manufacturer. Refer to the Parts List for replacement data for the US-FIP Pump & Cart parts. See the US-FIP Pump & Cart Disassembly section below for replacement instructions.

### INSPECTION

Remove only the front housing clamp and front cover to expose the impeller within the body.

Remove only the rear housing clamp and body with the impeller contained therein for inspection/replacement of the seal.

### DISASSEMBLY

1. Remove the front housing clamp (1) and front cover (2) with o-ring (3). Remove the o-ring from front cover and inspect for wear/damage.
2. Remove the rear housing clamp (1) and slide the pump housing (5), with impeller (4), off of the shaft (14). Remove the impeller from the body and inspect for wear/damage.
3. Remove back plate (6) with o-ring (3) by rotating counter-clockwise to disengage the retaining studs.

**CAUTION**

The seal spring will push the back plate forward when free of the retaining studs.

4. Remove the o-ring from the back plate and inspect for wear/damage. Remove the seal seat (7b).
5. Remove the seal face (7c) with o-ring (7d). Remove the o-ring from the seal face. Remove the wave spring (8) and



**WARNING**

Relieve pressure and remove all fluid from the US-FIP pump prior to disassembly.



**WARNING**

Remove power prior to servicing to prevent unintended start of the pump.

inspect. Remove the seal collar (9) from the shaft being careful not to mar or damage the shaft finish.

**Note for the following:** When removing drive components, it is necessary to tip the entire assembly back onto the handle bars, with a chock in place.

6. With a chock in place at one of the rear tires, tip the assembly back and remove the cap screws (P4) and belt guard (M) from the bottom of the base (L).
7. Loosen the mounting bolts (P2) securing the drive motor (B) to the base (L). (The bolt holes are elongated to permit belt adjustment).
8. Set the assembly upright, slide the motor (B) toward the pump (A), reach under the assembly and remove the drive belts (F).
9. Slide the motor back, tilt the assembly back and remove the bolts securing the motor pulley (E). The same bolts can be used as forcing screws to separate the pulley and bushing. Remove the bushing. Remove the pulley. Remove the motor mounting bolts (P2) and remove the motor (B).
10. Remove the bolts securing the pump pulley (K). The same bolts can be used as forcing screws to separate the pulley and bushing. Remove the bushing. Remove the pulley.
11. Loosen the four mounting bolts securing the pump (A) to the base (L). Set the assembly upright and remove the four bolts and lock washers. Lift the pump off of the assembly.
12. From the pump end of the bearing housing (12), remove the front lip seals (10), and retaining ring (11). Carefully withdraw the shaft and bearing assembly through the front of the bearing housing. (An arbor press or hydraulic press may

be applied to the drive end of the shaft to accomplish this. Be sure to protect the bearing/shaft assembly from dropping.) Remove the rear lip seal (16). Should the rear bearing (15) remain in the housing; it may be tapped or pressed out from the back.

13. Remove bearings (13, 15) from the shaft with an arbor press or hydraulic press (bearing pullers may also be used). While supporting the inner race of the bearing, apply steady pressure to the shaft until each bearing slides free. Do not hammer either end of the shaft, as this will damage the shaft.

### Assembly

#### Bearing Frame Assembly:

1. With steady pressure (as with an arbor or hydraulic press), press a sealed rear bearing (15) onto the drive end of the shaft (14); press a sealed bearing (13) onto the pump end of the shaft.
2. Press the shaft, with bearings, into the bearing housing.
3. Secure the bearing/shaft assy. with the retaining ring (11).
4. Place the front (10) and rear (16) lip seals in the bearing frame.

**NOTE:** Pre-assembled bearing frames are also available and include Items 10-17

5. Align the four support posts (N) and the pump mounting holes with the holes in the base (L), Reach under the assembly and slide the four long pump mounting bolts with locking washers (P1), through the base (L) from the bottom and up through the support posts. Thread each cap screw into the flange of the pump. Tilt the assembly back and tighten the four mounting bolts.



**WARNING**

Relieve pressure and remove all fluid from the US-FIP pump prior to disassembly.



**WARNING**

Remove power prior to servicing to prevent unintended start of the pump.

6. Install the pump pulley key, pulley and bushing (K) and tighten the bushing bolts to secure the pulley.
7. With the assembly upright, attach the motor to the base and secure with motor mounting bolts, lock washers and washers (P2) but leave loose to allow for motor adjustment. Position the motor forward as far as it will go and tighten two of the motor mounting bolts to temporarily secure the motor.
8. Tilt the assembly back and install the motor pulley key, pulley, and bushing (E) in the same manner as with the pump pulley while maintaining parallel alignment of the motor pulley with the pump pulley.
9. Place drive belts (F) on the motor and pump pulleys. Loosen the two motor cap screws used to secure the motor. The motor weight will pull tension on the belts. Proper belt tension is established when a deflection of 3/16" (4.7mm) can be achieved using 5 to 7 pounds of force on the belt.
10. Secure the motor and set the assembly upright.
11. Attach belt guard & secure with bolts, washers and lock washers.

Mechanical Seal:

1. The seal seat (7b) has a lapped surface on one side and a rubber surface on the opposite side. Carefully insert the seal seat into the back plate with the lapped surface facing out, away from the back plate. (Rubber-Side-Down)
2. Slide the stainless steel seal collar (9) **TO THE BASE** (bottom) of the shaft being careful not to mar or damage the shaft finish. Tighten both set screws with a 3/32 Allen wrench. Place the wave spring (8) over the seal collar. Fit a new o-ring into the ID of the stainless

steel seal face (7c). Place the stainless steel seal face onto the shaft and **ALIGN THE SLOTS WITH THE SET SCREWS.** The wave spring (8) will compress into the seal face (7c).

**DO NOT LUBRICATE SEAL!**



Pump Head

1. Place a new o-ring (3) into the groove on the back plate; align the retaining studs with the slots in the bearing frame, push and rotate clockwise into place.
2. Lubricate a new impeller (4) and rotate into the pump housing (5) until the impeller is about 1/2 way into the housing. With the impeller still sticking out of the top of this housing. Align the bottom of the pump housing with the back plate and secure with a housing clamp. Continue to rotate the impeller into the housing until seated.

**Use ONLY food grade silicone lubricants**

Clockwise Rotation – Rotate the impeller into the pump housing with blades bending counterclockwise.

Counterclockwise Rotation - Rotate the impeller into the pump housing with blades bending clockwise.

3. Place a new o-ring (3) into the groove on the front cover (2). Place the front cover onto the pump housing and secure with a housing clamp (1).



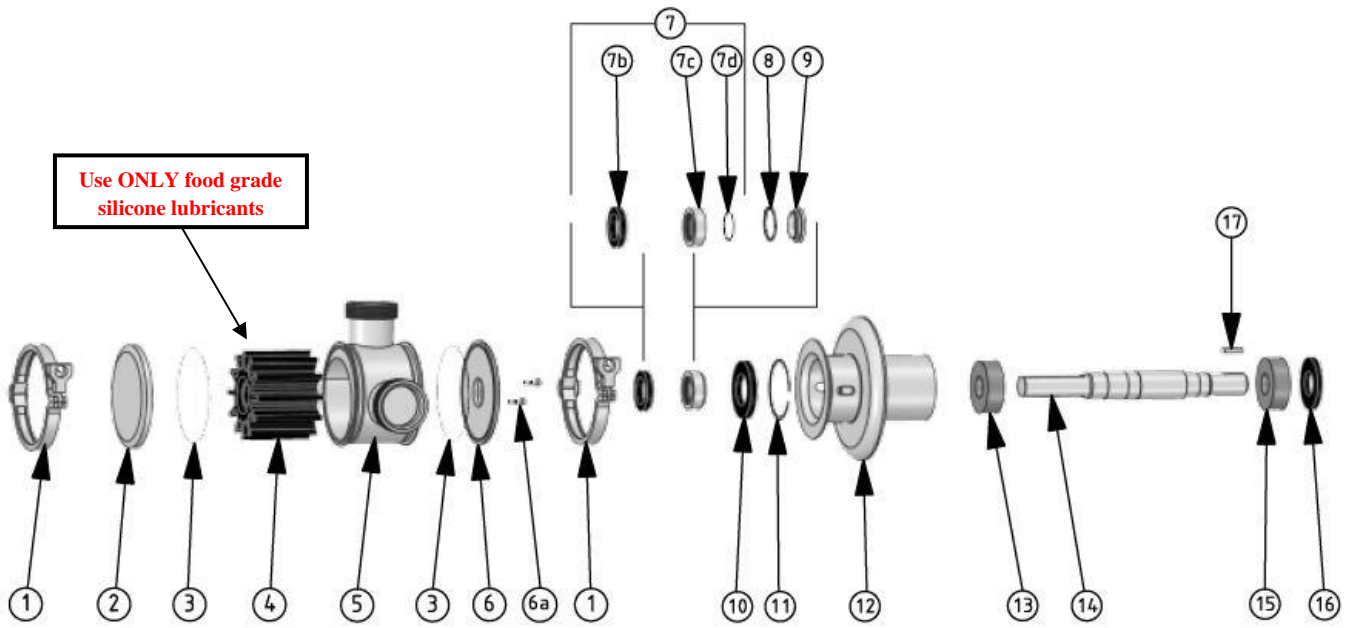

## Parts List

(See exploded view)

Part #	Description	Part #	Description		
1	US21909-0000	Housing clamp (2)	9	US22644-3101	Locked Rotating Seal Collar
2	US22007-0006	Front Cover	10	US92701-0880	Front Lip Seal (2)
3	US92000-1213-EPM	Housing O-ring (2)	11	US92701-4391	Retaining Ring
4	US8500-0005E	2.5" EPDM Impeller	12	US22064-0100	Bearing Housing
5	US22004-5001	2.5" Pump Housing	13	US92601-0461	Front Bearing
6	US21937-0006	Back Plate	14	US21978-0000	2.5" Shaft
6a	US21937-1000	Back Plate Shoulder Screws (2)	15	US92601-0451	Rear Bearing
7b	US22644-1001	Carbon Seal Seat	16	US92701-0881	Rear Lip Seal
7c	US22644-2101	Driven SS Seal Face	17	US91402-0270	Shaft Key
7d	US22644-3200-EPM	Seal Face O-Ring		US22644-6001	Driven Mechanical Seal Kit (7,8,9)
8	US22644-3300	Wave Spring		US22064-0001	Bearing Frame Assy. (10-17)

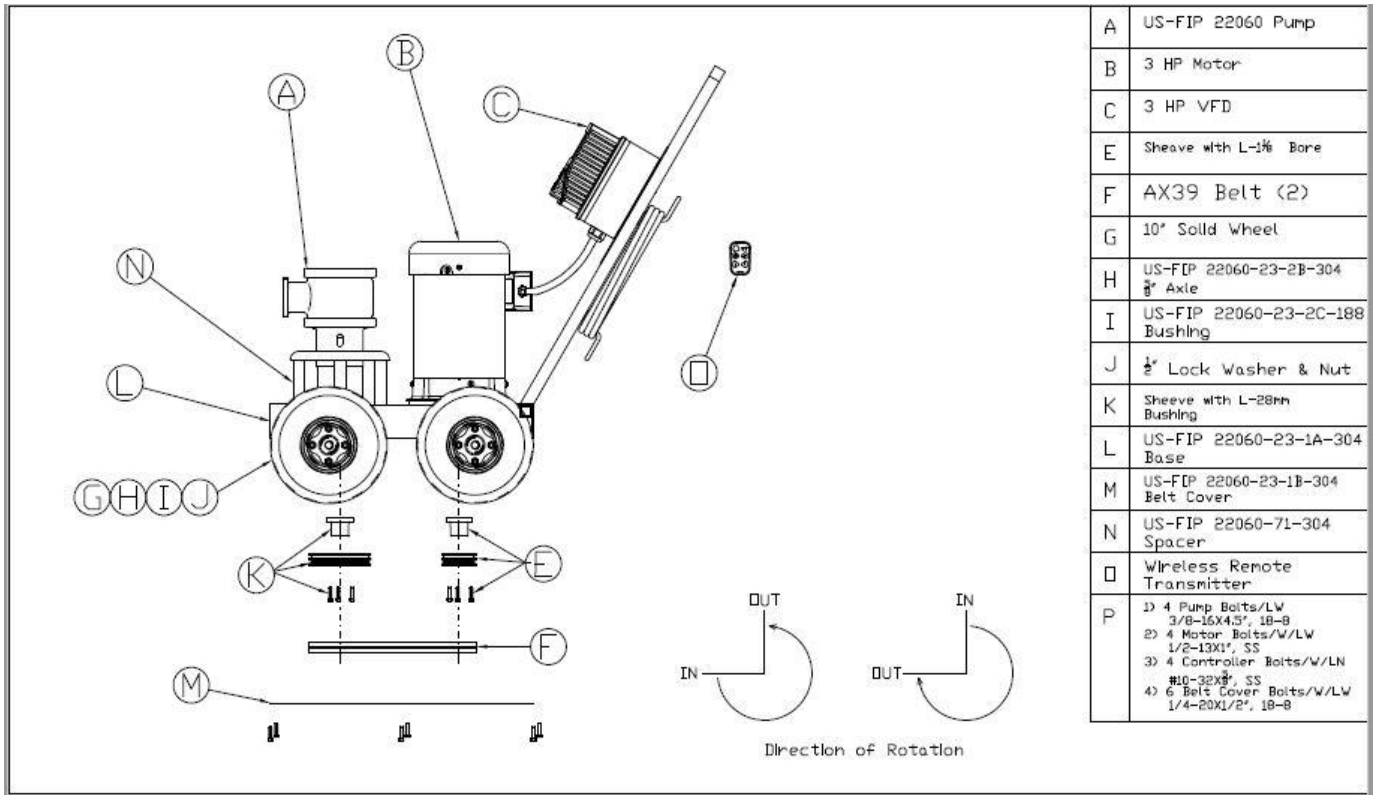

8920 58<sup>th</sup> Place, Suite 100, Kenosha, WI 53144  
(262)-909-0013

LeRoy Finnigan  
(262)-818-1381  
leroyf@mcfinntech.com

John McGinn  
(262)-909-7267  
johnm@mcfinntech.com

Please visit us at:  
[www.americanwinepump.com](http://www.americanwinepump.com)  
[www.americanbeerpumps.com](http://www.americanbeerpumps.com)  
[www.lowshearpumps.com](http://www.lowshearpumps.com)