

Available as:

## SALT CHLORINE GENERATOR SYSTEM



Available as:

## AFTERMARKET REPLACEMENT CELL



## USER'S MANUAL

(CFICGEN20, CFICGEN40, CFICGEN60)

# Contents

Important Safety Instructions-----	3
Water chemistry-----	4
Introduction Salt Chlorinator -----	10
Installation-----	12
LED Light Instruction-----	14
Operation-----	16
Maintenance-----	18
Troubleshooting -----	21
Limited Warranty-----	23

# IMPORTANT SAFETY INSTRUCTIONS

When using electrical equipment, please take basic safety precautions, including the following:



Please note, the total working hours for the CFICGEN should be less than 8 hours total per day. If you are using a variable speed pump for 24 hours a day be sure to adjust the chlorine output to 25-30%. If the pump is only running 10 hours per day adjust the chlorine output between 60-80%.

You can use this calculation to calculate the appropriate chlorine output for your pool, suggest at 6 hours per day.

Pump running 24(Hours a day)\*25%(Chlorine Output)=6hr (cell run time per day at 25%).

Pump running 20(Hours a day)\*30%(Chlorine Output)=6hr (cell run time per day at 30%).

Pump running 15(Hours a day)\*40%(Chlorine Output)=6hr (cell run time per day at 40%).

Pump running 12(Hours a day)\*50%(Chlorine Output)=6hr (cell run time per day at 50%).

Pump running 8(Hours a day)\*75%(Chlorine Output)=6hr (cell run time per day at 75%).

Start the VS pump on a low speed and kick the speed up until the salt system works.

ATTN: We are not affiliated with Pentair Pool Products, the use of any trademarks herein is for informational purposes only.

## READ AND FOLLOW ALL INSTRUCTIONS

- Please disconnect all AC power supplies during installation.
- Do not let children use this product.
- To reduce the risk of personal injury, the power pack must be installed and wired to the load side of the clock or the load side of the relay.
- To reduce the risk of electric shock, the power pack must be grounded.
- All metal parts installed on site, such as railings, ladders, drainage pipes or other similar hardware located within 10 feet (3 meters) of swimming pools, spas or hot baths, should be connected to the equipment grounding bus, American AWG/ Canadian 6 AWG, with a copper conductor not less than 8.
- Please consult professional swimming pool service personnel to provide you with correct use suggestions, especially material selection, installation suggestions and swimming pool maintenance. Because salt is an inherently corrosive substance, CFICGEN cannot ensure that any other equipment in or around the pool will not corrode.
- Avoid chlorine gas buildup. When the pump is turned off, a buildup of flammable gas will result in a hazardous situation.
- Add the acid to the water, not the other way around.

# WATER CHEMISTRY



**Note:** Dry acid can cause a build-up of by-products that can damage the chlorinator cells.

## CHEMISTRY NOTICE

**NEW POOL WATER:** Newly filled or refurbished pools may contain undesirable substances. Such undesirable substances may interfere with the CFICGEN's ability to properly chlorinate. Before turning on the CFICGEN, make sure the water has been tested and properly balanced by a professional pool.

**Super Chlorination:** Burns off swimmer waste that is bound to chlorine. This releases chlorine for disinfection. This can be accomplished by quickly and dramatically increasing the chlorine level. The water in the pool is considered super chlorinated when the chlorine level is raised to ten (10) times the total amount of chlorine. At the time the unit is turned on, the water inside the CFICGEN is highly chlorinated because the pool water is constantly flowing through the CFICGEN.

**Note:** On the initial start-up of a pool, it is best to super chlorinate using an outside source, i.e., use a shock treatment available at your local pool supplier.

**Chloramine** should not be present in the pool water. Ammonia (found in urine and sweat) combines with free chlorine to form chloramines. This will bind the free chlorine in the pool and will not allow the pool to be disinfected with chlorine. Chloramine can also burn eyes and give off a foul smell. At the initial start-up of the tank, chloramine is removed from the super chlorate as required to maintain an appropriate level of free chlorine.

**Cyanuric acid** is needed in outdoor pools to help stabilize and maintain proper levels of chlorine. Within two hours, UV rays from the sun will destroy 90% of the unstable chlorine. Cyanuric acid stabilizes the chlorine in the water and prevents UV degradation. Cyanuric acid levels should be maintained between 30-50 ppm when using CFICGEN. (See page 8)

**Note:** DO NOT USE CYANURIC ACID IN INDOOR POOLS.

**Total Dissolved Solids (TDS):** Adding salt to swimming pool water will raise the TDS level, while this does not adversely affect the pool water chemistry. For clarity, the pool water TDS professional testing personnel must be aware that salt has been added to the CFICGEN system. The person performing the TDS test (see page 17) can then subtract the salinity level to achieve a TDS level that is compatible with the TDS reading of a salt-free pool.

**Metals:** Certain metals, such as copper and iron, can cause chlorine loss. In addition, metals can stain your pool. Metals can also damage the CFICGEN. Have your local pool professional check for metals and recommend removal methods.

**Nitrates and phosphates** can cause extremely high chlorine demand and can deplete the pool of chlorine. In some cases, nitrates may even reduce your chlorine levels to zero. Your local pool professional can test for nitrates and phosphates. While the ideal nitrate level is 0 ppm, pool owners should ensure that nitrate levels do not exceed 10 ppm.

## IDEAL WATER CHEMISTRY LEVEL

<b>Voltage input</b>	230VAC/115VAC
<b>PH</b>	7.2-7.8
<b>Calcium Hardness</b>	50-300 for vinyl 220-320 for fiberglass 350-450 for plaster
<b>Total Alkalinity</b>	60-180 ppm
<b>Ideal Salt Level</b>	2610-4490 ppm
<b>Cyanuric Acid</b>	30-50 ppm
<b>Chlorine</b>	1-4 ppm

### How to test chlorine?

It is recommended that chlorine test samples be collected and compared from two (2) locations in the pool. A higher level should be found at the pool return line. The high liquid level in the tank return line indicates that CFICGEN is producing chlorine gas. Collect chlorine samples for testing at the following locations:

- The pool return line.
- 18 inches (457 mm) below the water surface, away from the pool return line.

### What kind of salt?

It is important to use only 99% pure sodium chloride (NaCl). This is a common food-grade salt or soft water salt, which is available in your local store, with a bag of 40-80 pounds. Water can also be used to adjust salt particles; However, they take longer to dissolve. Do not use rock salt, salt containing more than 1% yellow sodium cyanide, salt containing more than 1% anti-caking additive or iodized salt.

**For all newly surfaced plaster pools:** Do not use newly surfaced gypsum to operate CFICGEN. Salt is a corrosive element, and your swimming pool may be seriously damaged by salt. Wait at least one (1) month after construction to allow the gypsum to cure, then

add salt and operate CFICGEN. Follow the pool surface manufacturer's guidelines for your specific pool. Salt and operation CFICGEN.

**For new vinyl-lined pools,** contact the pool manufacturer for recommended guidelines prior to adding.

### How Much Salt to Use?

Use the table on page 7 to determine how much salt is needed. Most pools contain some salt, depending on the water source and the chemicals used to disinfect it. Therefore, pool owners must always test the salt level before adding salt. A handheld meter calibrated for NaCl (salt) can be used to determine the salt content of the water. The LEDs will provide information about the salt level.

- A salt level of 3400 ppm is recommended for optimal water quality.
- Low salt concentrations below 2300 ppm or above 6000 ppm will cause the unit to shut down

**Note:** Salt measurement values will vary depending on the measuring device (salt test strips, electronic testers and titrators). Salt sensor readings are accurate to within +/- 300 ppm. For more troubleshooting information on high salinity, see "Troubleshooting" on page 21.

### Saturation Index

The saturation index is a formula that measures the ability to dissolve or deposit calcium carbonate and is used as an indicator of the corrosiveness and temperature. The formula for well balanced water results in a range between -0.3 and +0.3, outside of which the pool water is considered out of balance and may damage the pool equipment or cause scaling of the CFICGEN.

The formula for Si: **SI = pH + CHF + AF + TF + TDSF.**

Cyanuric acid in the form of cyanurate ions contributes to the alkalinity. Therefore, the total alkalinity must be corrected. We subtract 1/3 of the cyanuric acid level from the reading obtained in the total alkalinity test.

Total Alkalinity - 1/3 Cyanuric Acid = Corrected Alkalinity

This correction can be considerable in established pools with high Cyanuric Acid levels; for example, at 100 ppm Cyanuric Acid, the correction amounts to 33 ppm (100/3 = 33.3).

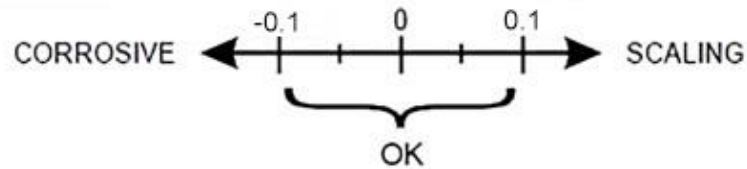

°C	°F	Ti	Calcium Hardness	Ci	Total Alkalinity	Ai
12	53	0.3	75	1.5	75	1.9
16	60	0.4	100	1.6	100	2.0
19	66	0.5	125	1.7	125	2.1
24	76	0.6	150	1.8	150	2.2
29	84	0.7	200	1.9	200	2.3
29	84	0.7	250	2.0	250	2.4
34	94	0.8	300	2.1	300	2.5
34	94	0.8	400	2.2	400	2.6
39	103	0.9	600	2.4	600	2.8
			800	2.5	800	2.9

**Note:** Use the closest reading on the chart

Total alkalinity in this document is the sum of carbonate and bicarbonate alkalinity. If cyanuric acid is used, a correction factor must be used.

## How to Add or Remove Salt

Check the salt level before adding or removing salt

### In ground pools:

Turn on the filter pump and add salt directly to the shallow end pool.

### Above ground pool with main drainage:

Add directly to the pool in front of the return nozzle. Run the filter pump for 24 hours with suction coming from the main drain (use pool vacuum if there is no main drain) to disperse the salt evenly throughout the pool.

### Above ground pool with no main drainage:

add directly to the pool. Brush salt to speed up the dissolution process-salt is not allowed to pile up at the bottom of the pool. Eliminate the following: Run the filter pump for 24 hours with suction coming from the main drain (use pool vacuum if there is no main drain) to disperse the salt evenly throughout the pool.

**In any pool, do not add salt directly to skimmers or to the main drain port. This will close or shorten the life of the cell due to high salt concentration and reduced pump flow**







**Amount of stabilizer (Cyanuric Acid) needed to obtain 40 ppm in pool  
(The Cyanuric Acid should be at 30-50 ppm)**

POUNDS and (kg) of STABILIZER CYANURIC ACID L NEEDED FOR 80 PPM									
Current Stabilizer Level (ppm)	0 ppm	10 ppm	20 ppm	30 ppm	40 ppm	50 ppm	60 ppm	70 ppm	80 ppm
14,000G 52,500L	9.4 lbs 4.3 kg	8.2 lbs 3.7 kg	7.0 lbs 3.2 kg	5.9 lbs 2.7 kg	4.7 lbs 2.1 kg	3.5 lbs 1.6 kg	2.4 lbs 1.1 kg	1.2 lbs 0.54 kg	0.0
16,000G 60,000L	10.7 lbs 4.9 kg	9.4 lbs 4.3 kg	8.0 lbs 3.6 kg	6.7 lbs 3.0 kg	5.4 lbs 2.4 kg	4.0 lbs 1.8 kg	2.7 lbs 1.2 kg	1.4 lbs 0.64 kg	0.0
18,000G 67,500L	12.0 lbs 5.4 kg	10.5 lbs 4.8 kg	9.0 lbs 2.2 kg	7.5 lbs 3.4 kg	6.0 lbs 2.7 kg	4.5 lbs 2.0 kg	3.0 lbs 1.4 kg	1.5 lbs 0.68 kg	0.0
20,000G 75,000L	13.4 lbs 6.1 kg	11.7 lbs 5.3 kg	10.0 lbs 4.5 kg	8.4 lbs 3.8 kg	6.7 lbs 3.0 kg	5.0 lbs 2.3 kg	3.3 lbs 1.5 kg	1.7 lbs 0.77 kg	0.0
22,000G 82,500L	14.7 lbs 6.7 kg	12.9 lbs 5.9 kg	11.0 lbs 5.0 kg	9.2 lbs 4.2 kg	7.4 lbs 3.3 kg	5.5 lbs 2.5 kg	3.7 lbs 1.7 kg	1.8 lbs 0.82 kg	0.0
24,000G 90,000L	16.0 lbs 7.3 kg	14.0 lbs 6.4 kg	12.0 lbs 5.4 kg	10.0 lbs 4.5 kg	8.0 lbs 3.6 kg	6.0 lbs 2.7 kg	4.0 lbs 1.8 kg	2.0 lbs 0.91 kg	0.0
26,000G 97,500L	17.3 lbs 7.9 kg	15.2 lbs 6.9 kg	13.0 lbs 5.9 kg	10.8 lbs 4.9 kg	8.7 lbs 3.9 kg	6.5 lbs 2.9 kg	4.3 lbs 2.0 kg	2.2 lbs 1.0 kg	0.0
28,000G 105,000L	18.7 lbs 8.5 kg	16.4 lbs 7.4 kg	14.0 lbs 6.4 kg	11.7 lbs 5.2 kg	9.3 lbs 4.2 kg	7.0 lbs 3.2 kg	4.7 lbs 2.1 kg	2.3 lbs 1.1 kg	0.0
30,000G 112,500L	20.0 lbs 9.1 kg	17.2 lbs 8.0 kg	15.0 lbs 6.8 kg	12.5 lbs 5.6 kg	10.0 lbs 4.5 kg	7.5 lbs 3.4 kg	5.0 lbs 2.3 kg	2.5 lbs 1.2 kg	0.0
32,000G 120,000L	21.3 lbs 9.7 kg	18.7 lbs 8.5 kg	16.0 lbs 7.2 kg	13.3 lbs 6.0 kg	10.7 lbs 4.8 kg	8.0 lbs 3.6 kg	5.3 lbs 2.4 kg	2.7 lbs 1.2 kg	0.0
34,000G 127,500L	22.7 lbs 10.3 kg	19.8 lbs 9.0 kg	17.0 lbs 7.7 kg	14.2 lbs 6.3 kg	11.3 lbs 5.1 kg	8.5 lbs 3.9 kg	5.7 lbs 2.6 kg	2.8 lbs 1.3 kg	0.0
36,000G 135,000L	24.0 lbs 10.9 kg	21.0 lbs 9.5 kg	18.0 lbs 8.1 kg	15.0 lbs 6.7 kg	12.0 lbs 5.4 kg	9.0 lbs 4.1 kg	6.0 lbs 2.7 kg	3.0 lbs 1.3 kg	0.0
38,000G 142,500L	25.3 lbs 11.5 kg	22.2 lbs 10.0 kg	19.0 lbs 8.6 kg	15.8 lbs 7.1 kg	12.7 lbs 5.7 kg	9.5 lbs 4.3 kg	6.3 lbs 2.8 kg	3.2 lbs 1.4 kg	0.0
40,000G 150,000L	26.7 lbs 12.0 kg	23.3 lbs 10.5 kg	20.0 lbs 9.0 kg	16.7 lbs 7.5 kg	13.3 lbs 6.0 kg	10.0 lbs 4.5 kg	6.7 lbs 3.0 kg	3.3 lbs 1.5 kg	0.0

## INTRODUCTION

The CFICGEN chlorine generator generates chlorine gas by electrolysis, and disinfects the swimming pool from salt molecules (NaCl) in water. A small amount of charge is applied to a group of titanium plates in the electrolytic cell. Sodium hypochlorite (NaOCl) is generated. In water, sodium hypochlorite is decomposed into sodium ion (Na<sup>+</sup>) and hypochlorite ion (OCl<sup>-</sup>). It is a hypochlorite ion that forms hypochlorous acid (HOCl) with hydrogen (H<sup>+</sup>) ions (from water). Hypochlorous acid is an active agent that destroys bacteria and algae and oxidizes organic matter. This form of chlorine acts quickly in the pipeline, leaving only a small amount of residue in the pool. In addition, the electrolytic bath constantly "impacts" the incoming water and burns any oil, organic matter or other particles that need to be oxidized.

Most importantly, this process continuously recovers salt: after cleaning the pool, the original molecules are re-formed and the whole process starts again. The salt doesn't get used up!

### THE COMPLETE CFICGEN SYSTEM CONSISTS OF A CELL UNIT AND A POWER CENTER:

- PLEASE NOTE: Units purchased as aftermarket cells will not include a power center and are intended to be connected to an existing power center.

**CFICGEN Cell:** The cell unit has LED screen readings and buttons, as well as temperature sensors and salt level sensors, which can produce chlorine gas at a specified output.

If the salinity in the pool water is too low or too high, the red LED will light up and the cell will be turned off until salt or water is added to the pool.

CFICGEN has self-cleaning cycle, which can reverse polarity and reduce calcium accumulation. This function turns the cell on and off regularly to minimize the accumulation of calcium and scale and further extend the cell life.

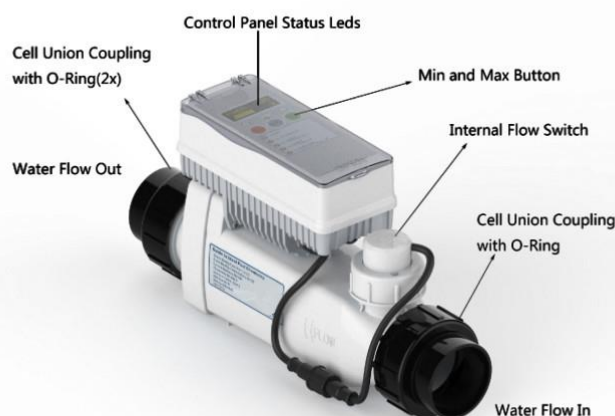

**CFICGEN Cell includes:** Control Panel, Flow sensor, Temperature sensor, Salt sensor

**Note:** The salt reading is around +/-300 ppm accuracy.

**CFICGEN Dual Voltage 115V-230V Power Center:** CFICGEN Power Center is a dual-voltage power supply, which means that there is no need for 115V/230V wiring. This power supply converts AC current into low-voltage DC current needed to generate chlorine gas.

The power center contains transformers, fuses, cell connectors and AC current wiring configuration, and DC current output cables are connected to CFICGEN. Fuses are installed in the housing to provide additional protection. For information about installing and using Power Center correctly, please refer to CFICGEN Installation.

CFICGEN can be used in 115v/230v and automatically converted.



**Warning: Incorrect wiring may lead to chlorine leakage:**

To reduce the risk of personal injury, the Power Center must be installed on the load side of the clock, the load side of the electronic control switch or relay and connected to the load side, so as to receive power only when the pool pump is turned on. Otherwise, dangerous chlorine gas accumulation may occur. When the pool pump is turned off and water is not flowing through the equipment, CFICGEN should never be energized.

Turn off the AC power supply before inserting and unplugging the model.

## INSTALLATION

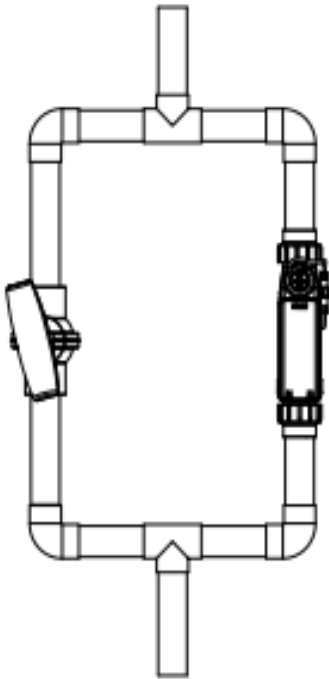

**Ensure that chlorine/bromine feeder is installed after CFICGEN Cell.**

When CFICGEN is used with the in-floor cleaning system, it is suggested to use a separate return pipe for the cleaner to reduce the increased hydraulic stress on the CFICGEN cell.

### Loop Plumbing Diagram

CFICGEN is designed to operate at a water flow rate of 25 +/- 5 gallons per minute (gpm) to 105 gpm. When the speed exceeds 80 gallons per minute, you must use the bypass circuit to obtain the best chlorine production. Installation with flow rate exceeding 80 gallons per minute includes installation with floor cleaning system or booster pump. These systems must use CFICGEN bypass loop with flow control valve to ensure that the flow through CFICGEN is kept within its designed working water flow.

### Plumbing Diagram

- Please be sure to install CFICGEN after the filter and heater. The CFICGEN shall be at least three (3) feet from the outlet of the heater.
- If CFICGEN is installed on the combined swimming pool/spa system, please install it before the backflow valve of the swimming pool/spa (see the figure below), so that both the swimming pool and spa can be properly chlorinated, and gas accumulation in the swimming pool water pipes can be avoided.
- Install CFICGEN cell horizontally.

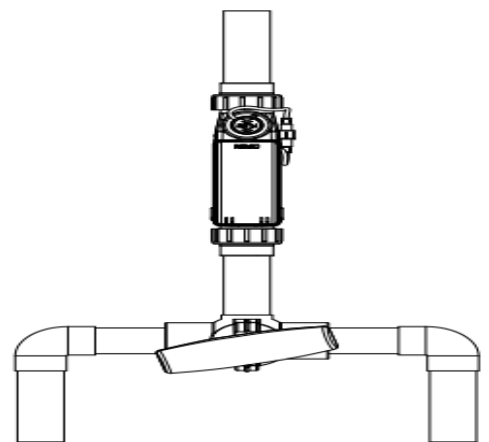

### Determine the size of the pool (gallons of water in the pool)

Rectangular Pools	Length x width x average depth x 7.5
Round Pools	Diameter x diameter x average depth x 5.9
Oval Pools	Length x width x average depth x 6.7
Bevel	Multiply total gallons by 0.85 = gallon capacity

### Determine the size of the pool (liter of water in the pool)

Rectangular Pools	Length x width (meters) x average depth x 1000
Round Pools	Diameter x diameter x average depth x 785
Oval Pools	Length x width (meters) x average depth x 893
Bevel	Multiply total liters by 0.85 = liter capacity



**Caution:** In order to protect the service life of CFICGEN, do not use dry acid (sodium bisulfate) to adjust the pH value in arid geographical areas, which will cause excessive evaporation and minimize the dilution of pool water with fresh water.

**ATTENTION:** Make sure you have disconnected the power supply before installing! Grounding (earthing) is required. This unit should be installed and grounded by qualified service personnel. Installed to allow access to unit buttons and power centers.

**Please read the safety precautions and important instructions on page 1. Be sure to read and observe the safety instructions before making any electrical wiring. Wiring can only be done by qualified professionals.**

- The CFICGEN shall be installed at least three (3) feet from the outlet of the heater.
- Pipe coupling: Schedule 80, with a maximum pressure of 75 psi at 70F (21°C).

#### How to install Cell (new installations):

*Please note: when cell is used for aftermarket replacement, installation is not normally necessary; the cell will connect to existing threaded couplers.*

1. Install the PVC coupling to the plumbing pipe with PVC glue. Let the glue dry.
2. Install the cell vertically. Allow access to the unit operator control panel. Install the cell on the coupling. Make sure that the O-ring is properly seated.
3. Turn on the pump and visually check whether there is leakage around the coupling.

## Connecting the CFICGEN Cell Cable to the Power Center



**Warning-Please turn off the power of the main system before making any connection.**

1. Before connecting the power cord to the power center, please make sure that the AC power supply is turned off.
2. Align the two (2) pins of the cell power cord connector with the socket on the top of the power supply.
3. Center and insert the connector. Turn the round socket nut until the connector is locked in place.

The CFICGEN power center is a dual voltage of 115V-230V, which will automatically switch without additional wiring.

**Please note:** these components will not connect to automation.

## LED LIGHT INSTRUCTION



### SUPERCL / SALINITY:

#### **SHORT PRESS:**

Show the salinity.

#### **LONG TIME PRESS** (Until the long press light become green) :

Enter into SuperChlor mode, long time press again to exit setup. SuperChlor mode will auto-exit after 24 hours.

#### **GENERATE:**

The light stably on means it is operating. The light off means it is something wrong.

### **COLD-WATER:**

Warning: the water temperature is out of range - lower than 10°C or higher than 50°C - the system is shut down.



**SALT:**

**GOOD LED ON:** Good salt.

It shows salt salinity is within the working range of 2600PPM-4450PPM.

**INSPECT SALT RED ON:**

Salt Level below 2300 PPM or above 6000 PPM

**INSPECT SALT RED (flashing)**

Salt Level: 2300 PPM to 2800 PPM/4500 PPM to 6000 PPM

**CELL:**

**GOOD LED ON:**

The cell is good and produces chlorine gas.

**INSPECT CELL RED:**

The cell needs to be inspected. The blades may contain calcium. The cell does not produce chlorine gas.

**FLOW:**

**GOOD FLOW LED ON:** enough water flows to produce chlorine gas.

**NO FLOW LED FLASHING:**

There is water flow. Continuous detection of water for one minute is necessary when the system starts. Or the flow of water is unstable.

**NO FLOW LED ON:**

No water in the cell.

**SANITIZE OUTPUT SETTING:**

Press the button MIN and MAX, 10% for each setting.

## OPERATION

**IMPORTANT:** An external pool pump timer required.

CFICGEN aims to provide enough chlorine to disinfect the pool water every day. If the pool pump runs continuously for 24 hours and CFICGEN runs at 100%, it will produce more chlorine than most swimming pools' need (1-4 ppm). CFICGEN has its own internal timer, which cycles the electrolytic cell on and off according to a set percentage of disinfectant output. For example, when the pool pump is running, the cell always keeps 100% working state. When set to 80%, the cell is allowed to rest for 20% when the pool pump is running, and the cell life is prolonged. In order to adjust CFICGEN to the size of your pool, just reduce the output time of disinfectant from 10% to 100% .



The CFICGEN can only produce chlorine. The CFICGEN cannot monitor or control the chlorine level in the pool or spa water. It is the pool owner's responsibility to monitor and maintain free chlorine levels between 1.0 and 4.0 parts per million (ppm) as recommended by the APSP. It is the pool owner's responsibility to check the free chlorine level during regular pool pump operation and adjust the sanitizer output on the CFICGEN accordingly.

### Start-up Procedure (Super Chlorination)

**Super chlorination is recommended prior to pool startup.**

Super chlorination should begin with clean chlorinated pool water.

The CFICGEN will accumulate sufficient levels of chlorine for sanitation within a few hours. The CFICGEN will not be able to produce enough chlorine to reach breakpoint chlorination. Super chlorination works better when performed at pool startup until the chlorine level returns to 1.0 to 4.0 ppm prior to turning on the CFICGEN.

### Output Settings and Adjustments

The output of chlorine is displayed by LED DISPLAY, and the salt concentration will be checked for 1/2 minute before work. If the salt content is normal, it will start to work, otherwise, please adjust according to the warning displayed on the LED display. For example, if the salt concentration is 2600 ppm, both the LED display screen and the LED salt inspection salt will indicate that there is not enough salt in the pool to produce chlorine.

To set the output, just press the **MIN** or **MAX** button.

For the first installation (after 24 hours of operation), please use a reliable test method to test the free chlorine in the pool water. The ideal range of maintenance is 1.0-4.0 ppm.

**If the level of free chlorine in the swimming pool water is too low, please press the "Maximum" button to increase chlorine production. If the free chlorine level in the pool water is too high, press the MIN button to reduce chlorine production.**

Due to the different demand for free chlorine in swimming pool water, it may take several days to determine the daily working hours of the swimming pool and the percentage setting of "disinfectant output" of the swimming pool. According to the suggestion of APSP, the adjustment should be continued as needed, and the interval between each adjustment should be 24 hours until the free chlorine level in the pool water is stable at 1.0-4.0 ppm.



**Precautions:**

- Don't get fertilizer in your swimming pool. Fertilizer contains phosphate/nitrate, which will lead to a high demand for chlorine.
- Never use dry acid to adjust pH value in arid areas, where evaporation is excessive and fresh water rarely dilutes pool water. The accumulation of by-products will damage CFICGEN.
- Do not add any pool water balancing chemicals (including salt) unless CFICGEN is turned off.
- Do not let the cyanuric acid content in the outdoor swimming pool drop below 30 ppm.

**Note: DO NOT USE CYANURIC ACID IN INDOOR POOLS.**

## MAINTENANCE

Every salt system requires maintenance after use, which is the focus of this section.

### Weekly Service

PH level test: 7.4 to 7.6, although 7.2 to 7.8 is an acceptable range under the APSP guidelines.

**Note:** Never use dry acid (Sodium bisulfate) to adjust pH value in arid areas, where evaporation is excessive and fresh water rarely dilutes pool water. The accumulation of by-products will damage CFICGEN.

**Total Alkalinity Test:** Use a reliable test method to test the total alkalinity of the pool water. Adjust according to the advice of swimming pool professionals. The ideal range of total alkalinity is 80-100 ppm.

**Chlorine Test:** Use a reliable test method to test the free chlorine of the pool water. Maintain the ideal range by adjusting the CFICGEN Sanitize output setting. See "minimum" and "maximum". Free chlorine needed: 1.0-4.0.

**Note:** Chlorine exceeding 4.0 ppm may cause excessive corrosion of metal parts and may damage related swimming pool equipment.

### Monthly Service

To ensure that your swimming pool maintains the correct chemical balance, it is very important to perform the following recommended salt and pool water tests every month with reliable test methods.

- Adjust salinity according to LED warning and LED DISPLAY.
- **Test salinity:** Press the salinity key to check the reading, or take the pool water samples to the local pool shop for testing.
- **Cyanuric Acid:** The pool water is sampled and the content of cyanuric acid is detected by reliable detection method. When CFICGEN is used, the recommended ideal cyanuric acid level is 30-50 ppm.
- **Calcium Hardness:** Use a reliable test method to test the calcium hardness of the pool water. Adjust according to the advice of swimming pool professionals if necessary. The ideal range of pool water calcium is 200-400 ppm recommended by APSP .

- **Metals Detection:** It is recommended to regularly sample the pool water to detect whether there are metals such as copper, iron and manganese. These metals can damage batteries and other related swimming pool equipment, so they should not appear in swimming pool water. If these metals are present, please contact your pool professional.
- **TDS (Total Dissolved Solids):** Use a test kit or let a pool professional test the water sample to test the TDS level of the pool water. Adjust according to the advice of swimming pool professionals if necessary. It is suggested that the APSP standard of salt pond should be at least 3000 to at most 5700-6000 ppm (including salt).

## Cleaning Blades

**Note:** Remove calcium buildup from the cell before acid cleaning: Use a garden hose on the spray setup and spray directly into the ends of the cell. Most of this calcium buildup has a muddy consistency and will be blown out of the cell. Once most of the calcium has been removed, continue with the acid wash as most of the calcium has been removed and the acid wash will now be more effective.

**Auto Clean:** The CFICGEN has an automatic cell blade cleaning feature (cell reversal) that helps remove scale deposits from the CFICGEN. **Note:** Automatic cleaning does not interrupt chlorine production. "Scale" is a white crusty deposit that forms when the water is too hard or when the pool water is out of balance and scales. If excessive scale is present on the blade, acid cleaning is required.

**Acid Cleaning:** If the CFICGEN blades show a tendency to scale, it is recommended that the CFICGEN be removed and inspected for scale and/or debris formation on the CFICGEN blades every two (2) months. Areas of high hardness may require more frequent cleaning. Some filters allow debris to pass through the CFICGEN and may become trapped between the blades of the CFICGEN. A small amount of scale formation is normal. If a look through the CFICGEN reveals excessive scale formation between the blades or the presence of debris, the CFICGEN must be cleaned as follows:

- Use a high pressure water jet from a garden hose. If the blades cannot be reasonably cleaned, disconnect the AC power from the power center.
- Mix one (1) quart of hydrochloric acid with one (1) gallon of tap water in a plastic bucket.

**Note:** Always wear rubber gloves and goggles when cleaning the CFICGEN. Always add acid to water; do not add water to acid.

- Screw the cap with gasket and o-ring onto the threaded end of the CFICGEN pool (cap, o-ring, and gasket are a part of the cleaning kit, sold separately).
- Place the CFICGEN vertically in a five (5) gallon bucket (to contain accidentally overflow). Pour the acid solution (as described in step) into the CFICGEN until it just covers the cell blades and salinity probe. Allow the acid solution to froth, then clean the blade.

**Note:** The acid should only be contained in the CFICGEN covering the blade. Try not to sprinkle acid on the outside of CFICGEN. If acid does spill on the outside of CFICGEN, please clean it with water.

- The foaming action begins, which is caused by the dissolution of scale (calcium carbonate) from the blade. If intense foaming is not started, there is no need to clean the blade to stop the cleaning process and continue to the next step.

**Otherwise, keep the blade immersed in the solution until the foam stops. However, do not leave the acid in the CFICGEN for more than thirty (30) minutes. Too much acid will damage the blade.**

- Take the CFICGEN out of the bucket and put it into an empty five (5) gallon bucket. Thoroughly rinse the inside and outside of the CFICGEN with clean tap water and inspect. If deposits are still visible, repeat the acid cleaning process.
- After cleaning, replace the cell and return to normal operation.
- If an acid cleaning procedure is required, it is recommended that the pool water sample be analyzed by a pool professional for excessive calcium hardness (i.e., ideal range of 200 to 400 ppm) and/or improper water balance.
- Check the interior of the CFICGEN every two (2) months (or more frequently in hard water areas). If no scale or debris deposits are observed inside the CFICGEN after four (4) months, it is not necessary to check.
- Continue to check every two (2) months. However, due to possible changes in pool water chemistry and filtration, it is recommended that the cell be removed for inspection at least twice a year.
- Reconnect the CFICGEN communication cable plug at the power center, then reconnect AC power to the CFICGEN power center.



## TROUBLESHOOTING

PROBLEM	POSSIBLE CAUSE	SUGGESTED ACTION
<b>Low or no chlorine residual in pool</b>	Sanitizer Output percentage set too low or off at 0%	Increase Output Level.
	Insufficient run time	Increase run time to at least 1 hour per 10° ambient temp.
	Heavy pool use, inclement weather, organic matter	Activate Super CL mode or chemically shock pool.
	Water chemistry issues: Low Chlorine Stabilizer Low salt in the pool (less than 2300 ppm) Phosphates in pool Nitrates in pool	Contact pool professional, ensure all chemicals
	The cell is dirty, clogged, or Has excessive scaling or mineral build-	Remove Cell from plumbing, inspect and clean (see p.13).
<b>Low or no chlorine residual in pool after recent installation</b>	Water chemistry was not balanced prior to system installation and a high chlorine demand persists.	Contact pool professional, ensure all chemicals on p.6 are within range, chemically shock pool if necessary.
<b>Red Inspect Cell Led is on.</b>	It is time to clean the Electrolytic Cell.	The Cell must be cleaned.
	Cell efficiency has been greatly reduced.	Inadequate water flow exists, or Cell must be replaced.
<b>Red Inspect Salt Led is on.</b>	Pool water salt is too low or too high, system is off. Less than 2300 or Over 6000 ppm	Correct the salinity level.
<b>Red Inspect Salt Led is flashing</b>	Pool water salt is low or high, 2300 PPM to 2800 PPM/4500 PPM to 6000 PPM. 2300-2600, the system is still	Correct the salinity level.
<b>No Power</b>	Fuse/Reset has tripped.	Check fuses on power center
	No AC Power to the power center	Check the connection
<b>No Flow LED is on.</b>	Incorrect installation	Verify Sensor probe correct orientation
	Sensor probe is dirty or clogged.	Ensure correct connection, clean the sensor probe if necessary.

	Insufficient circulation	Ensure operation of the pump, at least 25-30 GPM. Check water level, filter pressure, or for air or blockages in PVC plumbing.
<b>Water leak</b>	O-Ring improperly seated	Ensure O-Rings are clean and in good condition.
	Threaded collars are cross-threaded.	Inspect threads for damage, ensure that each screws back on without resistance.
<b>Cell frequently has mineral buildup</b>	This is due to imbalanced water chemistry and a high Saturation Index.	Ensure that your Saturation Index is at or near zero, to avoid damage or premature cell failure.
<b>Cell never or rarely has mineral buildup.</b>	Water may be corrosive due to imbalanced water chemistry and a low Saturation Index.	Ensure that your Saturation Index is at or near zero, to avoid damage or premature cell failure.
<b>COLD WATER Led is on.</b>	Water temperature is too hot or cold for operation.	Check operation of the heater, or turn off until the water temp is between 50° F TO 122 °F.
	Bad contact line contact of Sensor problem	Ensure Sensor probe is well-connected.
	Damaged Sensor problem	Contact manufacturer.

## How to calibrate salinity?

If you need to calibrate the salinity, please press "MIN" and "MAX" at the same time, and press several times quickly. When the display shows "SALT Tsys:", press "MAX" to lower the salinity, and press "MIN" to increase the salinity.

For example, the current salinity is 3720ppm, if you want to reduce 107ppm, press "MAX", then the current salinity is  $3720-107=3613$ ppm. The number 107, 108 etc. means 107ppm and 108ppm. If you want to increase the salinity, please press "MIN".

## LIMITED WARRANTY

The CFICGEN is warranted to be free from defects in materials and workmanship, under normal use and non-commercial application, for one (1) year, plus one year PRO-RATA (50%), per the schedule below. Proof of purchase is required. This limited warranty is extended exclusively to the original purchaser of the CFICGEN system and is non-transferable. The CFICGEN is intended for residential pool use and any commercial application (any pool that is not for private single-family use, or the use of which is subject to regulation) voids all warranties.

Two (2) year limited warranty schedule for the CFICGEN and its components. During year one:100%, during year two: 50%.

This limited warranty is subject to the following terms, conditions, and exclusions:

1. To obtain the benefits of this warranty, contact the Salt Pool System (CFICGEN) warranty department for troubleshooting.
2. Should a defect in any item or part covered by the warranty become evident during the warranty's term, warranty department will at its sole discretion repair or replace such item or part. Warranty department reserves the right to replace defective parts with new or refurbished parts. This warranty does not include the cost of labor or transportation charges for equipment or component parts to or from warranty department, or the removal, reinstallation, or any such costs incurred in obtaining warranty replacements or repair.
3. This warranty extends to the original retail purchaser and original installation site only, beginning at the original date of purchase, and is non-transferrable.
4. The warranty contains the following exclusions. O-Rings, rubber gaskets, electrical fuses, and circuit-breaker components are normal replacement items subject to wear and are excluded from the warranty. Product discoloration, or any other cosmetic or superficial damage or deterioration, regardless of its cause, is not covered by this warranty. The warranty is not applicable to problems arising from circumstances outside the control of Products, including, but not limited to the following:
  - A. Damage or premature wear due to improper pool chemistry, and failure to maintain pool water chemistry in accordance with the recommendations contained in the owner's manual.
  - B. Damage due to improper installation or connection to improper voltages, including materials and workmanship supplied by others.
  - C. Damage due to negligence or failure to properly maintain equipment, including the maintenance of clean and tight electrical connections.
  - D. Damage due to improper service, as well as unauthorized equipment modifications and use of non-genuine replacement parts.
  - E. Damage due to misapplication, misuse, abuse, overuse the cell lifetime (over 10 hours per day) or failure to operate equipment as specified in the owner's manual.
  - F. Problems resulting from tampering, accident, fire, flood, freezing, lightning, insects, or other natural elements, or other circumstances beyond the control of Products.
  - G. Damage due to over-tightening of threaded components or excessive pressure or stress.

H. Material supplied or workmanship performed by others in the process of installation. Damage or degradation of any equipment, surfaces, or materials in or around the swimming pool or spa area, including but not limited to concrete, stone, wood, metal, synthetic materials, or vegetation.

The liability of Salt Pool System (CFICGEN) shall not exceed the repair or replacement of defective items or parts under the referenced limited warranty terms. There are no other express or implied warranties of merchantability or fitness for a particular purpose that apply to this equipment. Under no circumstances shall Salt Pool System (CFICGEN) manufacturer, distributor, or dealer, the agents, employees, and affiliates be liable for any loss, damage, injury, inconvenience or loss of time, incidental expenses such as labor and material charges, or any other indirect, special, incidental, or consequential damages which may result from the use, installation, removal, or reinstallation of its equipment and parts.

This warranty is valid only in the United States of America. This warranty gives you specific legal rights and you may also have other rights, which vary from state to state. This warranty supersedes all previous publications. Any dispute between the original purchaser and Salt Pool System (CFICGEN) manufacturer will be settled by binding arbitration, conducted in Mecklenburg County, NC, under the rules of the American Arbitration Association.

Disclaimer: This limited warranty is the entire warranty. No other warranties apply, expressed or implied. This limited warranty gives you specific legal rights, which varies accordingly from state to state. Under no circumstances shall the manufacturer or authorized agents/installers be responsible for consequential, special, or incidental damage(s) of any kind, including but not limited to personal injury, property damage or loss, or equipment damage or loss. The manufacturer or agents/installers are not liable for any other expenses that may be encountered during installation or servicing. Authorized agents/installers may charge a trip fee for warrantable service work. Some states do not allow the exclusion of limitations of incidental or consequential damages. Listed exclusions and limitations may not apply to you.