

Rail-Merge

User Guide



Please read these instructions before using the product.

This product has been designed & manufactured for professional use only. It should only be installed by a suitably qualified technician and in accordance with electrical regulations in the country of use.

Unless directed in the instructions there are no user serviceable parts inside the outer case of this product.

Always disconnect from the power supply when not in use.

Any specific IP rating, where appropriate, is given in the instructions. Unless otherwise stated this product is designed for indoor use only. If used outdoors it **MUST** be installed in an appropriate IP rated cabinet. Do not allow this product to be exposed to rain or moisture. Do not allow liquid to penetrate the product.

Please recycle all packaging.

Copyright © Artistic Licence Engineering Ltd. All rights reserved.

Download the user guide by scanning the following QR code:



Connections

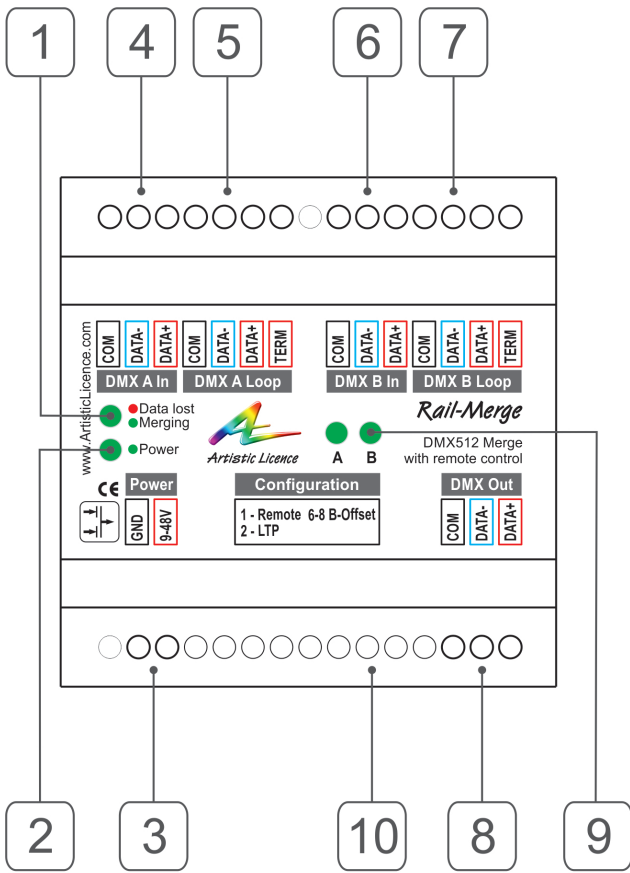

Reference	Type	Description
1	LED	Data merging status
2	LED	Power
3	Connection	Power Input
4	Connection	DMX512 Input A
5	Connection	DMX512 Loop & Term (A)**
6	Connection	DMX512 Input B
7	Connection	DMX512 Loop & Term (B)**
8	Connection	DMX Output
9	LED	Input data activity
10	Configuration	DIP switches (see Table 1)

** A passive loop-through connection allows onward connection to other DMX512 devices. If this feature is not required then the signal must be terminated. The product contains an internal termination resistor. This is enabled by fitting a wire link between **Term** and **DAT+**.

Mounting Diagram

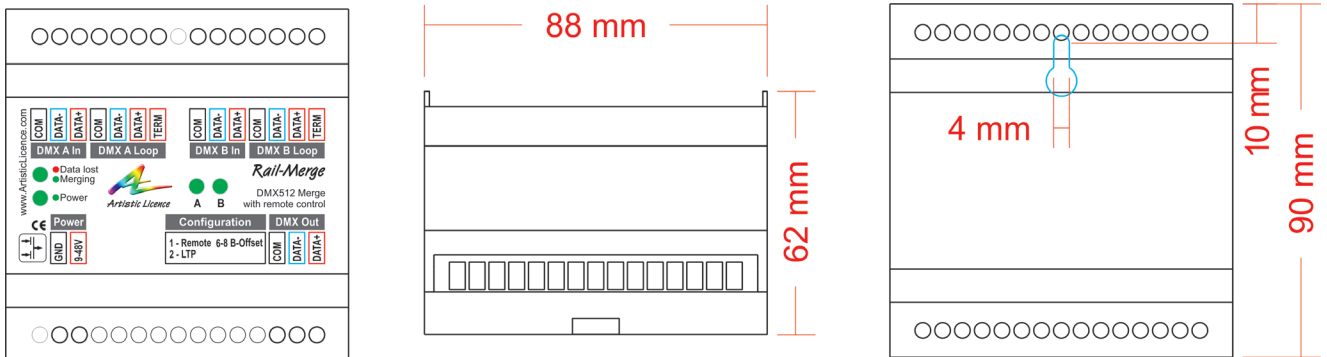

Overview

Rail-Merge is a DIN rail mounted product that merges two DMX inputs to one DMX output. The inputs are independently isolated with a high level electrical protection. It is configured via an 8-way DIP switch that enables operation in remote or standalone mode, and numerous user-selectable options.

Rail-Merge is designed for situations in which there may be multiple controllers but only one DMX line. This is often the case in theatres, where the house lights and moving lights tend to be controlled by separate consoles. Rail-Merge provides a useful means of getting all the data onto the DMX line from different locations within the building.

Key features

- Two DMX inputs, any speed or number of slots
- Independent input optical isolation
- Remote control or standalone operation
- 8-way DIP switch configuration
- LTP or HTP merge
- Overlay or concatenate merge modes
- 9 - 48 VDC PSU required
- Surface mount or DIN rail mounted

DMX512 Wiring

XLR Pin (Convention)	Function	Colour
1	Ground	Black
2	Data -	Blue
3	Data +	Red

Connections

Input

The DMX512 inputs are independently isolated from each other and are each attached via three screw terminals. Please refer to the connections diagram. The product only handles zero start code data, so NSC and RDM data are ignored.

Loop-through

A passive loop-through connection allows onward connection to other DMX512 devices. If this feature is not required then the signal must be terminated. The product contains an internal termination resistor. This is enabled by fitting a wire link between the screw terminals that will terminate the DMX line.

Output

A single DMX512 output is provided. This is isolated from the inputs and referenced to the power supply ground.

Internal Earth and Isolation

Circuit	Description	
DMX512 Input A (including Loop Through)	Type:	Isolated
	Common	Connects to internal isolated circuit. No connection to Internal Logic Ground or Input B
DMX512 Input B (including Loop Through)	Type:	Isolated
	Common	Connects to internal isolated circuit. No connection to Internal Logic Ground or Input A
DMX512 Output	Type:	Ground referenced
	Common	Connected to Internal Logic Ground
Internal Logic Ground	Connects to Ground Power Input	

Operation

Rail-Merge offers two basic modes of operation: standalone or remote. The mode is set using Switch 1 (see Table 1). Within each mode, the following options can be set:

Merge type

The DMX inputs, A and B, may be merged such that 'latest takes preference' (LTP) or 'highest takes preference' (HTP). Generally, the latter is used for intensity, and the former for everything else.

Merge offset

The B input can be offset by a specific number of channels (see Table 2 for standalone mode and Table 3 for remote mode).

Concatenate (standalone mode only)

The B input is simply added to the end of the A input. This could be used to append the house lights control to the moving lights control.

Remote masters (remote mode only)

Channels 511 and 512 of Input A are used as master faders for the A and B levels respectively when in HTP mode.

Configuration

Rail-Merge is configured via an 8-way DIP switch to the right of the output connector. Table 1 below explains the settings.

Switch	Function	Notes
1	On = Enable Remote Control	See Table 3. This switch overrides all others.
2	On = LTP / Off = HTP	
3	Future expansion	
4	Future expansion	
5	Future expansion	
6	Offset of B input (LSB)	See Table 2
7	Offset of B input	
8	Offset of B input (MSB)	

Table 1: DIP switch settings

Any change to DIP switches will momentarily clear the merged output data. This can be used to cancel LTP merged output.

Standalone mode

Standalone Mode is enabled when Switch 1 is OFF. Merging can operate on LTP or HTP basis, as defined by Switch 2.

Switches 6, 7 and 8 are used to define how input B is offset relative to input A. Table 2 explains the settings.

B starts at:	Switch 6	Switch 7	Switch 8
1	OFF	OFF	OFF
25	OFF	OFF	ON
49	OFF	ON	OFF
97	OFF	ON	ON
121	ON	OFF	OFF
145	ON	OFF	ON
257	ON	ON	OFF
Concatenate	ON	ON	ON

Table 2: Standalone mode settings

In concatenate mode, the B input is started after the last slot of the A input. Clearly this is only useful if the A input has a footprint of less than 512 slots. This is the reason why concatenate mode is not available using remote control.

Remote control mode

Remote Control Mode is enabled when Switch 1 is ON. **All other switches are ignored in this mode.**

Channels 507 – 512 of DMX input A are used to define operation as follows:

DMX slot	DMX value	Function
507	0 - 127	HTP merge
	128 - 255	LTP merge
508	> 128	Pulse above 50% to clear LTP hold status and momentarily zero output
509	Offset B MSB	These channels form a number in the range 0 - 511 that defines the offset of the B input.
510	Offset B LSB	
511	0 - 255	A Master (HTP)
512	0 - 255	B Master (HTP)

Table 3: Remote control settings

LED Indication

The indicator meanings are explained below.

Data:

Green = DMX merging

Red = Data has been lost on an input

Power:

Green = Power

A, B input:

The LEDs illuminate in solid green to show good data on the relevant input. When data is disconnected, the LED will go out after 3 seconds.

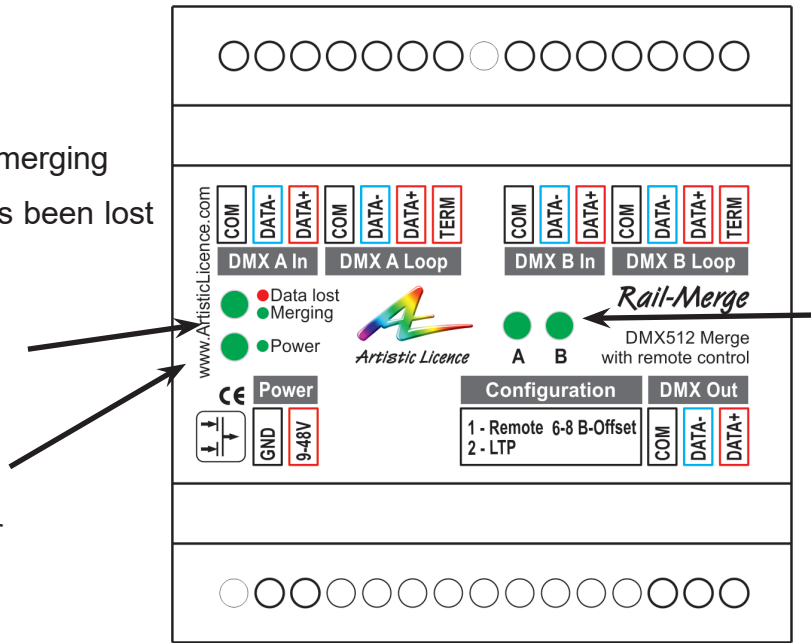

Application Diagram

The diagram below shows how Rail-Merge could be utilised in a typical application. The product is operating in standalone mode and set to concatenate the A and B inputs.

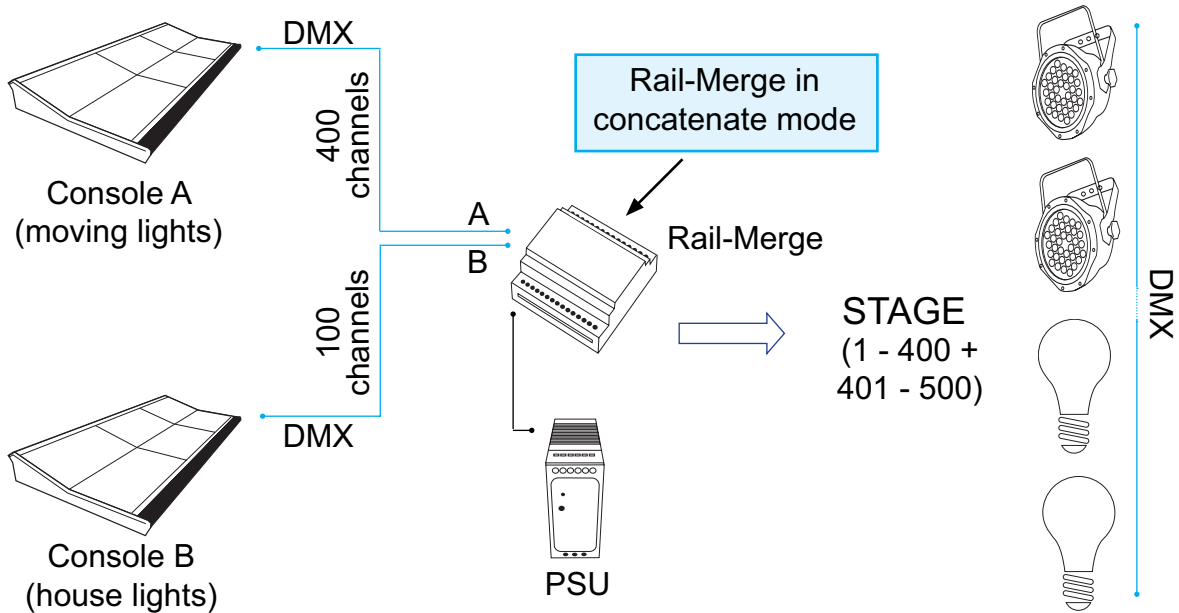

Rail-Merge Specification

<p>Mechanical</p> <ul style="list-style-type: none">• Housing: DIN rail case• Material: Lexan Plastic - UL94-V0 rated• Overall dimensions: 90 mm (H) x 88 mm (W) x 62 mm (D)• Weight: 0.25 kg• Mounting: 35 mm DIN rail or surface mount• Country of manufacture: UK	<p>DMX512 Inputs</p> <ul style="list-style-type: none">• Input mode: Independently optically isolated• Input isolation: 1 kV• Input ESD protection: 15 kV• Input voltage protection: +/- 80 V
<p>Environmental</p> <ul style="list-style-type: none">• Operating temperature: 0°C to 40°C• Storage temperature: -10°C to +50°C• Operating relative humidity (max): 80% non-condensing• IP rating: IP20 indoor use only• Certification: CE, WEEE, RoHS• Warranty: 2-year (return to base)	<p>Control</p> <ul style="list-style-type: none">• Input Protocols: DMX512, DMX512 (1990), DMX512-A• Output Protocols: DMX512-A
<p>Power & Electrical</p> <ul style="list-style-type: none">• Input voltage: 9-48 VDC• Input connector: 2-pin screw terminal (1 no.)• Input power (max): 1 W• Duty cycle: 100% @ 25°C• DC fuse: internal resettable fuse for control electronics	<p>Configuration</p> <ul style="list-style-type: none">• DIP switches (8 no.)• User configurable options:<ul style="list-style-type: none">- Remote or standalone mode- LTP or HTP merge- B input merge offset- Concatenate mode (standalone mode only)
<p>DMX512 Output</p> <ul style="list-style-type: none">• Output mode: ground referenced• Output isolation: n/a• Output ESD protection: 15 kV• Output voltage protection: +/- 80 V	<p>Data Connections</p> <ul style="list-style-type: none">• 3-pin Screw Terminal DMX Input (2 no.)• 3-pin Screw Terminal DMX Loop (2 no.)• 3-pin Screw Terminal DMX Output (1 no.)
	<p>LED Indication</p> <ul style="list-style-type: none">• Power / Merging status / Input data activity
	<p>Package Contents</p> <ul style="list-style-type: none">• Rail-Merge• User guide
	<p>Ordering Info</p> <ul style="list-style-type: none">• Product code: Rail-Merge
	<p>Accessories (not included)</p> <ul style="list-style-type: none">• PSU-9-1.5-FER

Compliance

All Products manufactured or sold by Artistic Licence Engineering Ltd are fully compliant with the appropriate CE and RoHS regulations. Product specific information is available on request.

Waste Electrical & Electronic Equipment (WEEE)

Artistic Licence is a member of a WEEE compliance scheme and will happily recycle any of our products that you, at your expense, return to us.

Warranty

All products are covered from date of purchase by a two-year return to base warranty.

By return to base, we mean that the customer is responsible for all costs of transport to and from Artistic Licence.

Returns will not be accepted without prior authorisation. In order to discuss a request to return goods, please email:

Sales@ArtisticLicence.com

CE Compliance

Rail-Merge is CE compliant when installed in a shielded and earthed metal case



Artistic Licence

The Mould Making Workshop
Soby Mews
Bovey Tracey
TQ13 9JG
United Kingdom

Telephone +44 (0) 20 8863 4515

Email: Sales@ArtisticLicence.com

Web: www.ArtisticLicence.com

Support@ArtisticLicence.com

Due to our policy of continuing product improvement specifications are subject to change without notice

