



Artistic Licence



matisse d4 dmx

User Guide



Please read these instructions before using the product.

This product has been designed & manufactured for professional use only. It should only be installed by a suitably qualified technician and in accordance with electrical regulations in the country of use.

Unless directed in the instructions there are no user serviceable parts inside the outer case of this product.

Always disconnect from the power supply when not in use.

Any specific IP rating, where appropriate, is given in the instructions. Unless otherwise stated this product is designed for indoor use only. If used outdoors it **MUST** be installed in an appropriate IP rated cabinet. Do not allow this product to be exposed to rain or moisture. Do not allow liquid to penetrate the product.

Contains small parts. Please keep out of reach of young children.

Please recycle all packaging.

Copyright © Artistic Licence Engineering Ltd. All rights reserved.

Download the user guide by scanning the following QR code:



Connections

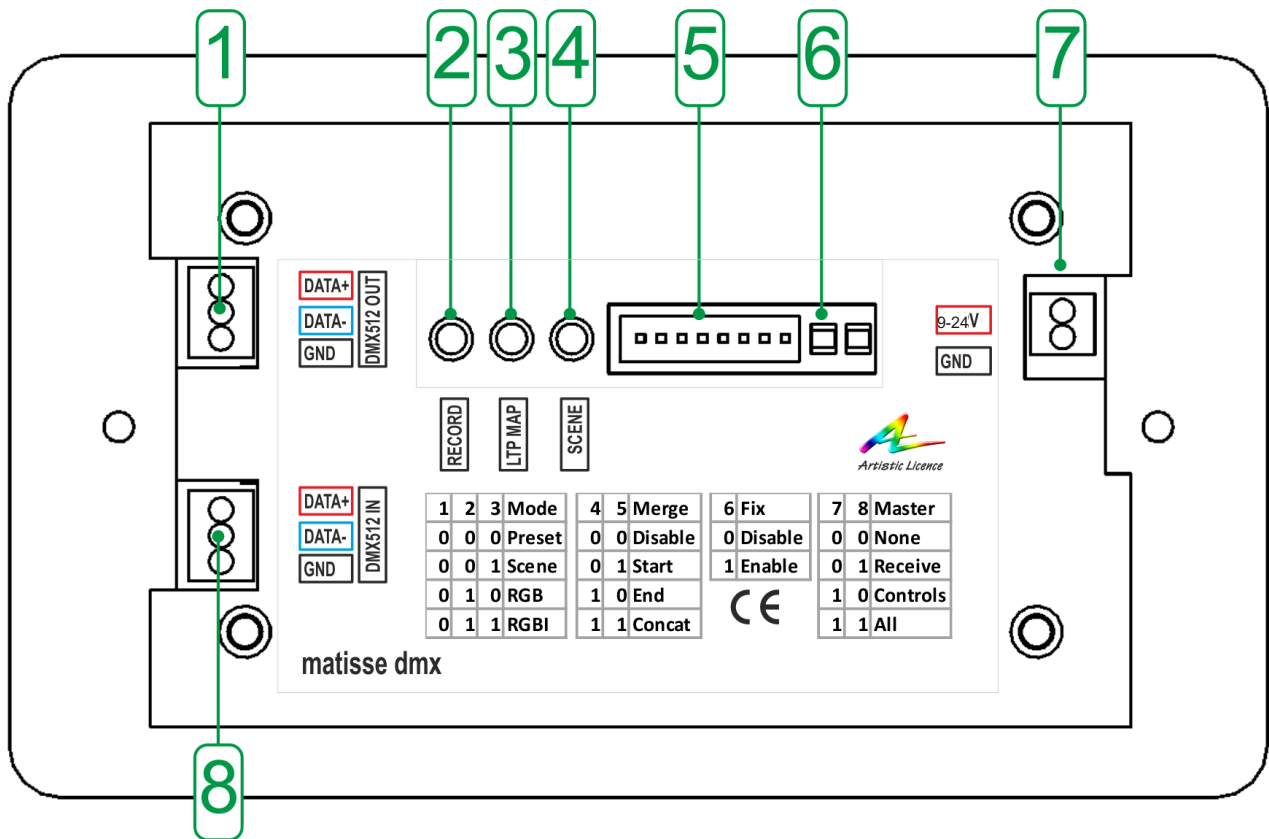

Ref.	Type	Description
1	Data Connection	DMX output
2	Programming	Record button
3	Programming	LTP map button
4	Programming	Scene button
5	Mode Configuration	DIP switches
6	LED indication	DMX/ Programming/Mode change
7	Power Connection	9-24 VDC
8	Data Connection	DMX input

Mounting Diagram

The product depth is 24mm so it will fit in a minimum 35mm back box. A 47mm backbox is recommended.

The product features a cosmetic cover plate (this needs to be separately purchased). The design is compatible with the Scolmore CLICK Definity range.

The material finish options are chrome, brushed steel, stainless steel, matt black with chrome dial, matt black, polished white.

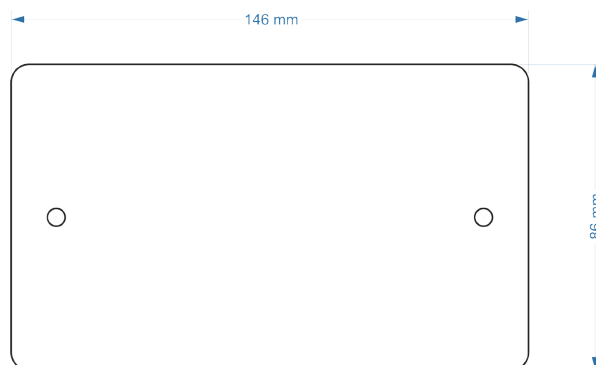

Product Overview

The matisse d4 dmx is a multi-function DMX controller with 4 dials. It is presented in a standard wall panel. All the electronics are mounted on the rear of the panel, so there is no need for external control boxes.

Depending on the operational mode chosen, each dial can control a single output channel (preset mode) or RGBI colour (hue fader mode). Additionally, in scene mixer mode, each dial can playback a 512 channel scene; the scenes can be mixed together with the dials operating as masters. LTP/HTP can be programmed on a per channel basis.

Other features include the ability to merge the output of the product onto received DMX512, and to use dial 4 as a grand master.

An external source of DMX512 is required for scene mixer programming. All configuration or programming is achieved with a simple set of configuration switches on the rear panel.

matisse d4 dmx requires a cosmetic cover plate which can be optionally purchased with the product. Artistic Licence resells the Scolmore CLICK Definity range, which is compatible with the d4 design.

The material finish options are: chrome, brushed steel, stainless steel, matt black with chrome dial, matt black and polished white.

Summary of Key Features

- Wall mount DMX controller
- DMX512 output
- 4 rotary dials
- 512 channel output
- Grand master control
- Multiple functions including preset, scene mixer, hue fader and merge mode
- Supports data merging (LTP/HTP) and data fixing
- Simple DIP switch configuration
- Easy push-button programming - no external software required

- Link multiple panels to one DMX cable
- Choice of cover plates in contemporary material finishes
- External 9-24 VDC PSU required

Connections

The DMX input and output use 3-pin screw terminals. Please refer to the connections diagram.

Power

matisse d4 dmx is powered from an external DC power supply (9-24 VDC). We recommend the PSU-9-1.5-FER. It is recommended that a ferrite core be fitted onto the DC power lines as close as possible to the product. This protects the unit from any electrical spikes that appear on the DC line.

LED Indication

matisse d4 dmx has an LED indicator on the back of the product which gives the following informational messages:

- Constant green = Normal operation and DMX is being received
- Flashing green = Normal operation and no DMX is being received
- Constant red = Programming button is pressed
- Pulse red and green = Programming operation completed
- Pulse red = Mode changed by DIP switch or loss of DMX

Operational modes

matisse d4 dmx can operate in a number of modes, determined by the DIP switch settings (see page 6).

Preset mode

In preset mode, each dial controls a single output channel.

Scene Mixer

A full 512 channel scene can be recorded onto each of the dials. These scenes can then be mixed together with the dials operating as masters.

Mixing operates in either LTP or HTP mode, which is selected on a channel by channel basis.

Hue Fader

In Hue mode, each dial controls either three (RGB) or four (RGBA) channels for colour control. The dial selects all possible hues while holding the saturation and intensity constant.

Grand Master

Dial 4 can be set to operate as a Grand Master for the preceding dials, the DMX512 input or both.

Data Fix mode

In this mode, the output speed of the DMX512 is slowed and 512 channels are transmitted.

Programming

To record a scene to be played back by the 4 dials:

- Set the product to scene mixer mode.
- Setup the required scene on the DMX input.
- Turn all the dials off (rotate fully anti-clockwise).

- Turn on the dial you wish to record to (rotate it fully clockwise). You can record to more than one dial if you wish.
- Hold down the record button (red LED comes on).
- Press and release the Scene button (red & green pulse for half a second to confirm).

The LTP map is used to define which channels are LTP vs HTP for Scene Mixer mode.

To record the LTP map:

- Setup the DMX input such that all channels to be HTP are at zero and all LTP channels are at full.
- Hold down the record button (red LED comes on).
- Press and release the LTP button (red & green pulse for one second to confirm).

When the record button is held down (all modes) the received DMX is output directly. This is useful to preview before recording.

The factory default is all channels set to HTP and each scene with channels 1 to 4 at full. This means that four-channel preset and scene mixer modes operate identically until user programming has occurred.

DIP switch settings

Operating Mode			
SW1	SW2	SW3	Description
Off	Off	Off	Four channel preset
Off	Off	On	Scene mixer
Off	On	Off	RGB Hue dials
Off	On	On	RGBI Hue dials

Merge		
SW4	SW5	Description
Off	Off	Merge disabled
Off	On	Merge over channel 1 of received DMX. Example: Received DMX has 7 channels. We are in 4-channel preset mode. Our 4 dials will output on channels 1-4.
On	Off	Merge over end of received DMX. Example: Received DMX has 7 channels. We are in 4-channel preset mode. Our 4 dials will output on channels 4-7.
On	On	Concatenate received DMX. Example: Received DMX has 7 channels. We are in 4-channel preset mode. Our 4 dials will output on channels 8-11.

Fix	
SW6	Description
Off	Fix disabled
On	Fix active - force transmit of all 512 channels at lower refresh rate

Master		
SW7	SW8	Description
Off	Off	No master
Off	On	Dial 4 used as master for received DMX
On	Off	Dial 4 used as master for dials 1-3
On	On	Dial 4 used as master for received DMX and dials 1-3

matisse d4 dmx Specification

Mechanical <ul style="list-style-type: none">• Housing: UK '2-gang' style panel with 35mm or 47mm (recommended depth) backbox (not supplied)• Overall dimensions: 86 mm (H) x 146 mm (W) x 24 mm (D)• Mounting screw centres: 120 mm• Mass: 0.2 kg• Country of manufacture: UK	Control <ul style="list-style-type: none">• Input Protocols: DMX512, DMX512 (1990), DMX512-A• Output Protocols: Same as input
Environmental <ul style="list-style-type: none">• Operating temperature: 0°C to 40°C• Storage temperature: -10°C to +50°C• Operating relative humidity (max): 80% non-condensing• IP rating: IP20 indoor use only• Certification: CE, WEEE, RoHS• Warranty: 2-year (return to base)	Data Connections <ul style="list-style-type: none">• Input - 3-pin screw terminals (1 no.)• Output - 3-pin screw terminals (1 no.)
Power & Electrical <ul style="list-style-type: none">• Input voltage: 9-24 VDC• Input connector: 2-pin screw terminal DC voltage input (1 no.)• Input power (max): 1W• Duty cycle: 100% @ 25°C	LED Indication <ul style="list-style-type: none">• DMX present / Programming / Mode change
User Interface / Indication <ul style="list-style-type: none">• Rotary dials (4 no.)	Configuration <ul style="list-style-type: none">• DIP switches and programming buttons
DMX512 Input & Output <ul style="list-style-type: none">• Output mode: PSU referenced• Output isolation: n/a• Output ESD protection: 15 kV• Electrocutation protection: 425 VAC continuous (self-healing)	Package Contents <ul style="list-style-type: none">• matisse d4 dmx
	Ordering Info <ul style="list-style-type: none">• Product code: matisse d4 dmx
	Accessories <ul style="list-style-type: none">• Mounting: Back-Box1• Power supply: PSU-9-1.5-FER• Cover plates:<ul style="list-style-type: none">- matisse d4 fascia bk- matisse d4 fascia bkch- matisse d4 fascia ss- matisse d4 fascia bs- matisse d4 fascia ch- matisse d4 fascia pw

CE Compliance



matisse d4 dmx is CE compliant

Warranty

All products are covered from date of purchase by a two-year return to base warranty.

By return to base, we mean that the customer is responsible for all costs of transport to and from Artistic Licence.

Returns will not be accepted without prior authorisation. In order to discuss a request to return goods, please email:

Sales@ArtisticLicence.com

Compliance

All Products manufactured or sold by Artistic Licence Engineering Ltd are fully compliant with the appropriate CE and RoHS regulations. Product specific information is available on request.

Waste Electrical & Electronic Equipment (WEEE)

Artistic Licence is a member of a WEEE compliance scheme and will happily recycle any of our products that you, at your expense, return to us.



Artistic Licence

The Mould Making Workshop
Soby Mews
Bovey Tracey
TQ13 9JG
United Kingdom

Telephone +44 (0) 20 8863 4515

Email: Sales@ArtisticLicence.com

Web: www.ArtisticLicence.com

Support@ArtisticLicence.com

Due to our policy of continuing product improvement specifications are subject to change without notice

