



MARC

BRINGS WARMTH TO LIFE



MARC

SPREADING SMILES SINCE 1981

Corporate Office:

Marc Enterprises Pvt. Ltd.

113 Badli Industrial Area, Phase-2, Delhi-110042

Phone: +91-11-47615000 | **Service Toll Free: 1800 1020 120** | Whatsapp: +91 80530 45635

Web: www.marcindia.biz | Email: marketing@marc.co.in

CIN: U74899DL1981PTC011991

Catalogue 2022-23

WATER HEATERS | ROOM HEATERS

COMPANY PROFILE

Established in 1981 in India, Marc Enterprises Pvt. Ltd. is a professional, high quality manufacturer engaged in production and development of Comfort Appliances specialising in Water heaters, Room heaters and Electric fans with experience of producing millions of units. The company is a leading manufacturer of Water Heaters and Electric Fans in India. Marc products have reached more than 10 million delighted customers.

The Company develops and designs its products at its own Research & Development center by Best-in-Class engineers. This also enables the company to make the right water heater for every application / Need / Capacity from 1 L to 100 L / Different aesthetic shape & colors / for diverse use be it a kitchen, Shower panel or Jacuzzi. Marc Water heaters come with various safety features like thermal cut-outs, multi function valves, thermostat controls etc. and built with Hi-grade material like Glass lined Incoloy Heating elements, Magnesium Rods, High density PUF insulation, weather resistant powder coat and Glass lined enamel tanks.

Our Vision:

To Spread Smiles to our Customers, with our Value Added Products, Services and commitment to Total Customer Satisfaction by delivering world class products and services.



Manufacturing Facilities

There are four State of the Art factories built over 30000 m². Equipped with latest technology machinery, Paint systems, Enamel coating systems and quality control equipment to ensure stringent Quality standards. Factories are ISO 9001-2015 certified.

Marc Kundli unit has been built with multiple product manufacturing and testing facilities for a range of water heaters (including the latest European Technology based Enamel Glass Line facility for inner tanks), Electric fans and Air Coolers.

Marc New unit established in Barota, Haryana (Near Kundli) is a dedicated Water Heater manufacturing unit.

Awards & Certifications



State of the Art Production Facility with European Technology



In-Built Quality Features For Better Experience

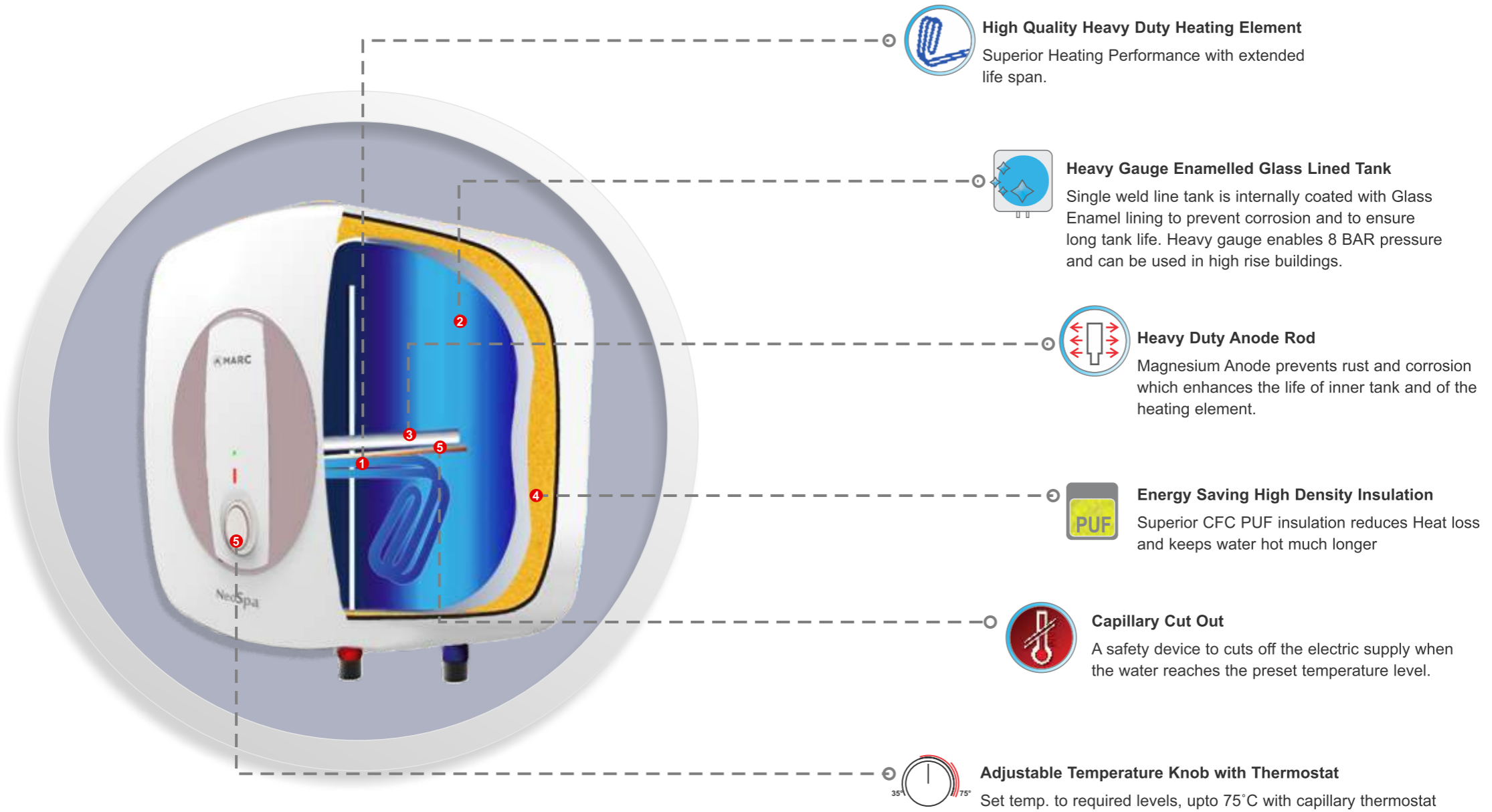

High Quality Heavy Duty Heating Element
Superior Heating Performance with extended life span.



Heavy Gauge Enamelled Glass Lined Tank
Single weld line tank is internally coated with Glass Enamel lining to prevent corrosion and to ensure long tank life. Heavy gauge enables 8 BAR pressure and can be used in high rise buildings.



Heavy Duty Anode Rod
Magnesium Anode prevents rust and corrosion which enhances the life of inner tank and of the heating element.



Energy Saving High Density Insulation
Superior CFC PUF insulation reduces Heat loss and keeps water hot much longer



Capillary Cut Out
A safety device to cuts off the electric supply when the water reaches the preset temperature level.



Adjustable Temperature Knob with Thermostat
Set temp. to required levels, upto 75°C with capillary thermostat



Storage Water Heater

Performance & Style

NEOSPA



Ivory
Rose Gold



White
Blue



7 Year on Water Heater Tank
4 Year on Heating Element
2 Year on Complete Product



BEE 5 STAR

Storage Electric Water Heater

Key Features



Single Weld line Enamel Glass line coated tank for Corrosion resistance



Temperature control knob: Set temperature upto 75°C



Pressure Rating : 8 Bar, Suitable for Pressure Pumps and High rise buildings.



Magnesium Anode prevents Rust and Corrosion even in Hard Water



2 KW, Heavy Duty Heating Element



Engineered polymer used for Rust and Corrosion Free Body



CFC free PUF insulation

Safety Features



Capillary thermostat - A safety device to cuts off the electric supply when the water reaches the preset temperature level.



Capillary type Cut-out cuts out the power and prevents temperature rise beyond 90°C, in the event of failure of thermostat.



Dry Heating Protection



Weather Proofing IPX2



Multifunction valve releases extra pressure when temperature exceeds limit, prevent water backflow, drain out water when safety level is breached and releases vacuum in case of faulty water flow.

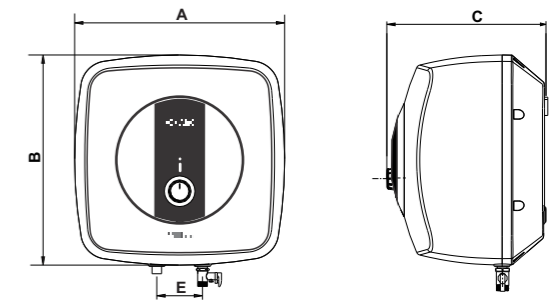

Technical Details						Product Dimensions		
Capacity (L)	Input Power (W)	Voltage (V)	Frequency (Hz)	Rated Pressure	Rated Temp. (°C)	A	B	C
6	2000	220-240	50	8 Bar	40-75	310	310	280
10	2000	220-240	50	8 Bar	40-75	390	390	280
15	2000	220-240	50	8 Bar	40-75	390	390	350
25	2000	220-240	50	8 Bar	40-75	460	460	390

**Specifications Subject to Change without Prior Notice.

OCTA M-SERIES



Storage Electric Water Heater

Key Features



Single Weld line Enamel Glass line coated tank for Corrosion resistance.



2 KW, Heavy Duty Heating Element suitable for hard water



Temperature control knob: Set temperature upto 75°C



Powder Coated Metal Body for strength and longevity



Pressure Rating : 8 Bar, Suitable for Pressure Pumps and High rise buildings.



CFC free PUF insulation



Magnesium Anode prevents Rust and Corrosion.

Safety Features



Capillary thermostat - A safety device cuts off the electric supply when the water reaches the preset temperature level.



Multifunction valve releases extra pressure when temperature exceeds limit, prevent water backflow, drain out water when safety level is breached and releases vacuum in case of faulty water flow.



Capillary type Cut-out cuts out the power and prevents temperature rise beyond 90°C, in the event of failure of thermostat.



Dry Heating Protection



7 Year on Water Heater Tank
4 Year on Heating Element
2 Year on Complete Product

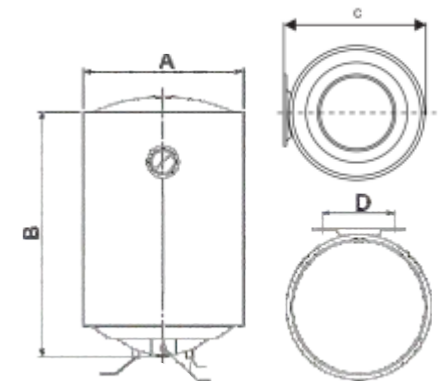

Technical Details							Product Dimensions			
Capacity (L)	Input Power (W)	Voltage (V)	Frequency (Hz)	Rated Pressure	Rated Temp. (°C)	Element	A	B	C	D
15	2000	220-240	50	8 Bar	40-75	CU	340	482	340	200
25	2000	220-240	50	8 Bar	40-75	CU	380	575	380	200

**Specifications Subject to Change without Prior Notice.

SOLITAIRE HEIGHTS



Horizontal Models Available in 15L & 25L Capacity, LHS & RHS options available

Storage Electric Water Heater

Key Features

- 

Single Weld line Enamel Glass line coated tank for Corrosion resistance
- 

Temperature control knob: Set temperature upto 75°C
- 

Pressure Rating : 8 Bar, Suitable for Pressure Pumps and High rise buildings.
- 

Magnesium Anode prevents Rust and Corrosion.
- 

2 KW, Heavy Duty Heating Element
- 

Engineered polymer used for Rust and Corrosion Free Body
- 

CFC free PUF insulation
- 

3 Star Rating for 15L & 25L HZ Models

Safety Features

- 

Thermostat - A safety device cuts off the electric supply when the water reaches the preset temperature level.
- 

Stem type Cut-out cuts out the power and prevents temperature rise beyond 90°C, in the event of failure of thermostat.
- 

Multifunction valve releases extra pressure when temperature exceeds limit, prevent water backflow, drain out water when safety level is breached and releases vacuum in case of faulty water flow.
- 

Dry Heating Protection



5 Year on Water Heater Tank
2 Year on Complete Product



For Vertical Models

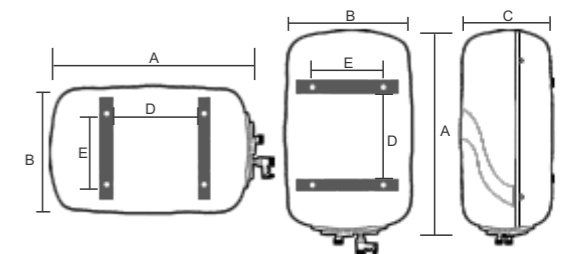

Technical Details							Product Dimensions				
Capacity (L)	Input Power (W)	Voltage (V)	Frequency (Hz)	Rated Pressure	Rated Temp. (°C)	Element	A	B	C	D	E
6	2000	220-240	50	8 Bar	40-75	CU	390	275	300	115	250
10	2000	220-240	50	8 Bar	40-75	CU	500	275	300	225	250
15	2000	220-240	50	8 Bar	40-75	CU	500	335	340	225	250
25	2000	220-240	50	8 Bar	40-75	CU	665	335	340	400	250
15Hz	2000	220-240	50	8 Bar	40-75	CU	500	335	340	225	250
25Hz	2000	220-240	50	8 Bar	40-75	CU	665	335	340	400	250

**Specifications Subject to Change without Prior Notice.

NEO CLASSIC



Available in 15L & 25L Capacity, LHS & RHS options available

Storage Electric Water Heater

Key Features



Single Weld line Enamel Glass line coated tank for Corrosion resistance



Temperature control knob: Set temperature upto 75°C



Pressure Rating : 8 Bar, Suitable for Pressure Pumps and High rise buildings.



Magnesium Anode prevents Rust and Corrosion.



2 KW, Heavy Duty Heating Element



Engineered polymer used for Rust and Corrosion Free Body



CFC free PUF insulation



3 Star Rating for 15L & 25L HZ Models

Safety Features



Capillary thermostat - A safety device cuts off the electric supply when the water reaches the preset temperature level.



Stem type Cut-out cuts out the power and prevents temperature rise beyond 90°C, in the event of failure of thermostat.



Multifunction valve releases extra pressure when temperature exceeds limit, prevent water backflow, drain out water when safety level is breached and releases vacuum in case of faulty water flow.



Dry Heating Protection



5 Year on Water Heater Tank
2 Year on Product



For Vertical Models

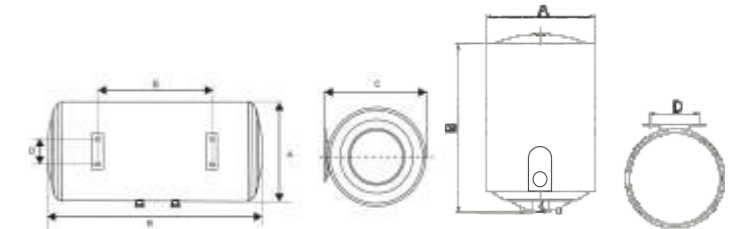

Technical Details							Product Dimensions				
Capacity (L)	Input Power (W)	Voltage (V)	Frequency (Hz)	Rated Pressure	Rated Temp. (°C)	Element	A	B	C	D	E
6	2000	220-240	50	8 Bar	40-75	CU	270	362	295	225	
10	2000	220-240	50	8 Bar	40-75	CU	336	383	361	225	
15	2000	220-240	50	8 Bar	40-75	CU	336	470	361	225	
25	2000	220-240	50	8 Bar	40-75	CU	357	620	382	225	
15Hz	2000	220-240	50	8 Bar	40-75	CU	336	470	361	225	280
25Hz	2000	220-240	50	8 Bar	40-75	CU	357	620	382	225	250

**Specifications Subject to Change without Prior Notice.

NEO CLASSIC M SERIES 35, 50, 70, 100L



50L

70L

100L



Available in 50L Capacity with center pipes / LHS & RHS options.

Storage Electric Water Heater

Key Features



Single Weld line Enamel Glass line coated tank for Corrosion resistance



Temperature control knob: Set temperature upto 75°C



Pressure Rating : 8 Bar, Suitable for Pressure Pumps and High rise buildings.



Magnesium Anode prevents Rust and Corrosion.



2 KW, Heavy Duty Heating Element



Engineered polymer used for Rust and Corrosion Free Body



CFC free PUF insulation



3 Star Rating for M-70
2 Star Rating for M-100

Safety Features



Capillary thermostat - A safety device cuts off the electric supply when the water reaches the preset temperature level.



Capillary Cut-out cuts out the power and prevents temperature rise beyond 90°C, in the event of failure of thermostat.



Multifunction valve releases extra pressure when temperature exceeds limit, prevent water backflow, drain out water when safety level is breached and releases vacuum in case of faulty water flow.



Dry Heating Protection



5 Year on Water Heater Tank
2 Year on Product



For M-35 & M-50 Models Only

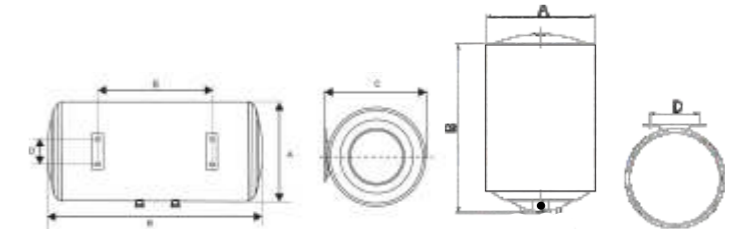

Technical Details								Product Dimensions				
Capacity (L)	Star Rating	Input Power (W)	Voltage (V)	Frequency (Hz)	Rated Pressure	Rated Temp. (°C)	Element	A	B	C	D	E
35	5	2000	220-240	50	8 Bar	40-75	CU	460	560	485	225	195
50	5	2000	220-240	50	8 Bar	40-75	CU	460	680	485	225	280
70	3	3000	220-240	50	8 Bar	40-75	CU	460	917	485	225	415
100	2	3000	220-240	50	8 Bar	40-75	CU	460	1182	485	225	662
50Hz	5	2000	220-240	50	8 Bar	40-75	CU	460	680	485	225	280

**Specifications Subject to Change without Prior Notice.

UNO DLX / UNO

Storage Electric Water Heater

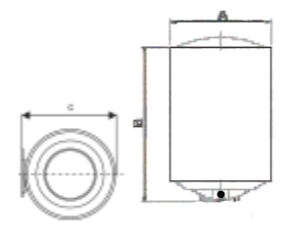

7 Year on Water Heater Tank
4 Year on Heating Element
2 Year on Complete Product
DLX Model Only

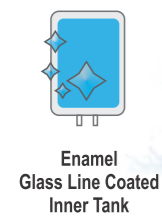

Enamel
Glass Line Coated
Inner Tank

Capacity Available in 6L, 10L, 15L, 25L



TEMP. SETTING
KNOB CUT-OUT
THERMOSTAT



CORROSION &
RUST FREE
BODY



HEAT RETENTION
WITH PUF
INSULATION



4 SAFETY
FEATURES



CAPILLARY
CUT-OUT



2 KW HEAVY DUTY
HEATING ELEMENT

Technical Details							Product Dimensions		
Capacity (L)	Input Power (W)	Voltage (V)	Frequency (Hz)	Rated Pressure	Rated Temp. (°C)	Element	A	B	C
6	2000	220-240	50	8 Bar	40-75	CU	275	330	290
10	2000	220-240	50	8 Bar	40-75	CU	315	355	340
15	2000	220-240	50	8 Bar	40-75	CU	315	465	340
25	2000	220-240	50	8 Bar	40-75	CU	360	555	385

Uno Model warranty 5 Year on Inner Tank and 2 Years on Product. 7 Years Warranty only for Uno DLX Models
**Specifications Subject to Change without Prior Notice.

SPOUT

Storage Electric Water Heater

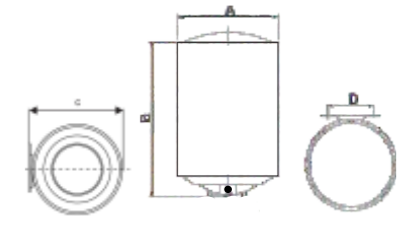

5 Year on Water Heater Tank
2 Year on Product



Capacity Available in 6L, 10L, 15L, 25L, 35L & 50L



TEMP. PRESET 75°
STEM TYPE
THERMOSTAT



CORROSION &
RUST FREE
BODY



HEAT RETENTION
WITH PUF
INSULATION



3 SAFETY
FEATURES



STEM TYPE
CUT-OUT



2 KW HEAVY DUTY
HEATING ELEMENT

Technical Details							Product Dimensions			
Capacity (L)	Input Power (W)	Voltage (V)	Frequency (Hz)	Rated Pressure	Rated Temp. (°C)	Element	A	B	C	D
6	2000	220-240	50	6.5 Bar	40-75	CU	265	330	275	215
10	2000	220-240	50	6.5 Bar	40-75	CU	265	480	290	215
15	2000	220-240	50	6.5 Bar	40-75	CU	320	510	320	215
25	2000	220-240	50	6.5 Bar	40-75	CU	350	615	350	215
35	2000	220-240	50	6.5 Bar	40-75	CU	425	620	390	215
50	2000	220-240	50	6.5 Bar	40-75	CU	425	780	390	215

**Specifications Subject to Change without Prior Notice.



**Instant
Water Heater**

Fast & Reliable

SORA

Instant Electric Water Heater



2 Year on Complete Product

Corrosion & Rust Free Body	3 KW Heavy Duty Heating Element	Stem Type Cut-out	SS-304L Tank made with S.C.J. Technology	6.5 BAR Pressure Rating
Stem Type Thermostat	Non Return Valve Prevents backflow	Pressure Release Valve	Fusible Plug for Extra Safety	PU Coated Trims for Smart looks

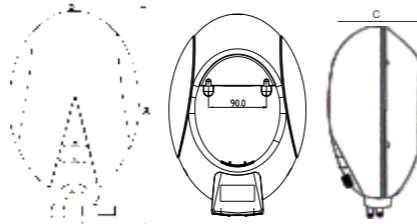

Technical Details							Product Dimensions			
Capacity (L)	Input Power (W)	Voltage (V)	Frequency (Hz)	Rated Pressure	Rated Temp. (°C)	Element	A	B	C	D
1	3000	220-240	50	6.5 Bar	40-75	CU	350	213	195	90
3	3000	220-240	50	6.5 Bar	40-75	CU	350	213	195	90
3	4500	220-240	50	6.5 Bar	40-75	CU	350	213	195	90

**Specifications Subject to Change without Prior Notice.

AGIRA

Instant Electric Water Heater



2 Year on Complete Product

Corrosion & Rust Free Body	3 KW Heavy Duty Heating Element	Stem Type Cut-out	SS-304L Tank made with S.C.J. Technology	6.5 BAR Pressure Rating
Stem Type Thermostat	Non Return Valve Prevents backflow	Pressure Release Valve	Fusible Plug for Extra Safety	

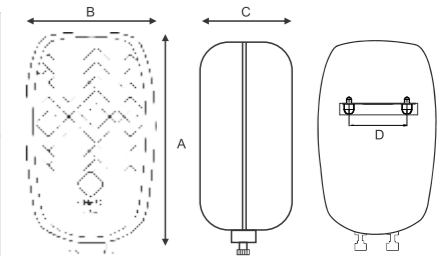

Technical Details							Product Dimensions			
Capacity (L)	Input Power (W)	Voltage (V)	Frequency (Hz)	Rated Pressure	Rated Temp. (°C)	Element	A	B	C	D
3	3000	220-240	50	6.5 Bar	40-75	CU	380	215	200	90
3	4500	220-240	50	6.5 Bar	40-75	CU	380	215	200	90

**Specifications Subject to Change without Prior Notice.

INSTA HOT

INSTA SPA

Instant Electric Water Heater



1 Year on Complete Product

Technical Details

Capacity (L)	Rated Pressure	Rated Temp. (°C)
6	3PSI	40-75
5	3PSI	40-75

<p>HEAT EXCHANGER TECHNOLOGY & THREE WAY TEMPERATURE CONTROL</p>	<p>1 KG COPPER HEAT EXCHANGER & SS BURNERS</p>
<p>AUTOMATIC GAS REGULATION & TWENTY MINUTE TIMER</p>	<p>LOW PRESSURE-RATED PRESSURE 3 PSI</p>



Immersion Water Heater

SHOCKPROOF Immersion Water Heater SP-1000 / SP-1500



Safe Shockproof Plastic handle



Heavy Duty Copper Element



Advance Technology 100% Safe even submersed in water



Available in: 1 kW & 1.5 kW



Immersion Water Heater IR-1000 / IR-1500



Heavy power cord & Hanger Loop Cord Protector

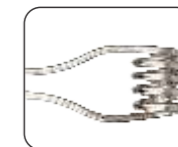

Heavy Duty Copper Element



Minimum and Maximum Water level indication marks to avoid dry heating



Available in: 1 kW & 1.5 kW



**Specifications Subject to Change without Prior Notice.

Room Heaters

Quick & Efficient

Marc Room Heaters

Marc Room Heaters are designed and manufactured using latest technology and features keeping in mind they keep you warm and comfortable even in extreme Cold Temperatures. We have variety of choices in the heater segment to meet your requirements like OFR, Halogen Heater, Quartz Heater and Heat Convector. Marc room heaters have been tested under different climatic conditions and have achieved highest satisfaction level to meet all customer requirements.

Take Pleasure in Living

Marc offers quality products for a comfortable good living. Marc room heaters evenly heats the entire room quickly and efficiently, providing greater safety, convenience, warmth and energy efficiency.

The heating series from Marc have smart and elegant looks and compliment any home.



OIL FILLED RADIATOR

Why Choose Marc Oil-Filled Radiator

Oil heaters are a smart heating solution if you consider all the aspects of a space heater.

Energy Efficient Heater

Oil filled heaters efficiency is significantly higher than other heaters. Oil filled radiators can provide heat for a long period of time even after they are switched off. Marc OFR with 3D ECO-Fins conducts heat more efficiently compared to traditional straight fins.

Safe to Use

- + Does Not dry out air
- + No Humidity Loss
- + Sealed in Oil, thus no leakage
- + Does not burn Oxygen in Room



Tilt Over Switch for Safety



ECO-Fins with high heating efficiency



Thermostat for better & reliable temperature control



Three Power Settings



Over Heat Protection



Room Heater



OFR - 9Fin

- Noiseless Operation
- Three Heat Settings
- Eco-Fins with high heat efficiency
- Maintains Oxygen Level
- Built in Safety Features
- Easy Control for Convenience
- Adjustable Thermostat to maintain desired temperature
- Power Indicator Lamp
- PTC Fan 400W
- Wattage 2000W

OFR - 11Fin

- Noiseless Operation
- Three Heat Settings
- Eco-Fins with high heat efficiency
- Maintains Oxygen Level
- Built in Safety Features
- Easy Control for Convenience
- Adjustable Thermostat to maintain desired temperature
- Power Indicator Lamp
- PTC Fan 400W
- Wattage 2400W



1 Year on Complete Product

*Due to continuous development the product pictures may vary from actual product

HEAT PILLAR

Room Heater

- 2 Quality Quartz Heating Elements for instant heating
- Low Power Consumption
- High Energy Efficiency
- Safety Front Grill
- 2 Heat Settings : 750W/1500W
- Quality Stainless Steel Reflector
- Convenient Wrap Around Storage
- Auto rotation from left to right and right to left
- ISI Mark



1 Year on Complete Product

QUARTZ HEATER

Room Heater

QH-800DLX/QH-1200DLX

- Stylish Design
- Cool Touch Body
- 2/3 Quality Quartz Heating Element for Instant heating
- Three Heat Settings 400W/800W/1200W
- Noiseless Operation
- Safety Tip Over Switch
- Safety Front Grill
- Easy portability
- 3 Pin Plug with PVC Cord
- Energy Efficient
- ISI Mark



1 Year on Complete Product

HALOGEN HEATER HH-1200DLX



- Stylish Design
- Cool Touch Body
- Three Heat Settings
- Noiseless Operation
- Halogen Heating Elements
- Safety Tip Over Switch
- 3 Heat Settings : 400W/800W/1200W
- 90° Automatic Oscillation from left to right and right to left
- 3 Pin Plug with PVC Cord
- ISI Mark



1 Year on Complete Product

QUARTZ HEATER QH-500DLX

- Stylish Design
- Cool Touch Body
- 2 Quality Quartz Heating Element for Instant heating
- Two Heat Settings 400W
- Noiseless Operation
- Safety Tip Over Switch
- Safety Front Grill
- Easy portability
- Energy Efficient
- ISI Mark

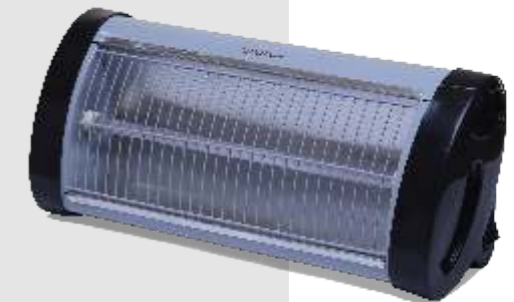

1 Year on Complete Product

ROD HEATER - RH-1000 & RH-2000

Room Heater



- Stylish Design
- Nickle Plated Protective Mesh and Reflector
- Nichrome Wire Element
- Noiseless Operation
- Easy portability
- Powder Coated Body
- ISI Mark
- Available in One or Two Rod Room Heater 1000W/2000W



1 Year on Complete Product



HEAT CONVECTOR

- 2 Heating Options
- Neon Indicator for easy visibility at night
- Safety Device Thermal Cut-out
- Swing stand to get Hot Air at different angle
- Easy Portability and Handling
- Powerful Fan for quick spot heating
- Wattage: 1000W/2000W
- ISI Mark



1 Year on Complete Product

We at Marc believe in customer satisfaction and we consistently strive to achieve it with Quality assurance and after sales service.

Quality Assurance

Our Philosophy of customer first leads us to build water heater with multiple safety features, high grade material and energy efficiency ensuring longer product life. The entire manufacturing goes through a series of stringent quality checks and processes maintaining standards providing assurance of a Quality product.

After Sales Support

We at Marc have strong network of customer support and are sure to delight our customers for years to come. We follow standardised customer support processes and with a network of Marc authorised service centers, we provide direct and precise quality after sales support to our customers.

Customer Support Contact

For any service related Queries, Contact
 Toll Free Helpline: **1800 1020 120** Direct Line: +91-11-47615000
 Email: care@mar.co.in