

HEXCAL[®] INSPIRE

Ergonomic Chair User Manual

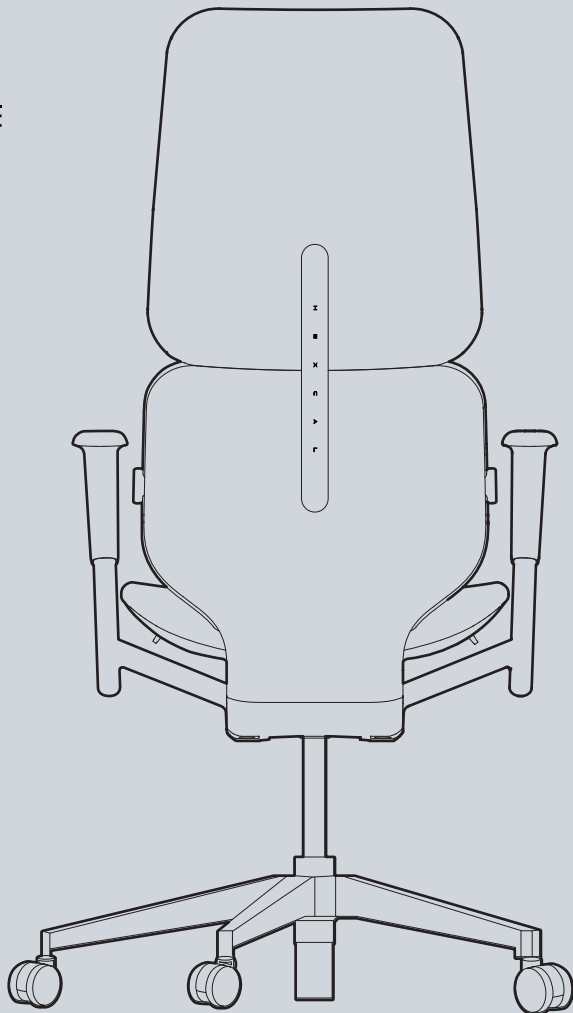

PRODUCT OVERVIEW

Applicable Environment: Indoor use, not suitable for open air and humid environment

Product Purpose: Suitable for study room, office, business workspace and others

Loading Capacity: 136kg or less (300 lbs or less)

Carried Standard: Applicable Standards, ANSI BIFMA X5.1, EN1335, QBT 2280

Safety Precaution: Can not ride backwards. Torsion spring should not be adjusted too loose. Keep balance with the floor.

Suitable Age: At least 12 years old

MATERIALS

Backrest Cover: seat pad cover and armrest: high-density thermoplastic polypropylene

Filling: high-density polyurethane foam

Air Spring: steel inner and outer tube, filled with nitrogen

Structure Of Control Body: powder-coated aluminum alloy/polymer nylon/high-strength spring

Wheel Base: high-load-bearing powder-coated aluminum alloy

Caster: polymer nylon/elastomer polyurethane

In the Box

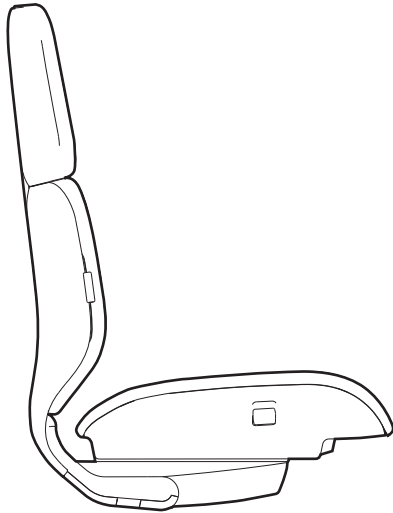

Chair Body (x1)

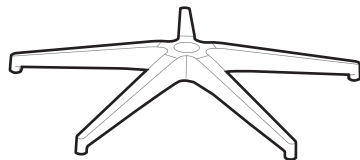

Wheel Base (x1)



M8 Screw (x2)



Allen Key (x1)



Caster (x5)



Gas Lift (x1)

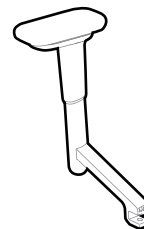

Right Armrest (x1)

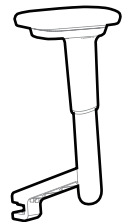

Left Armrest (x1)

Assembly Process

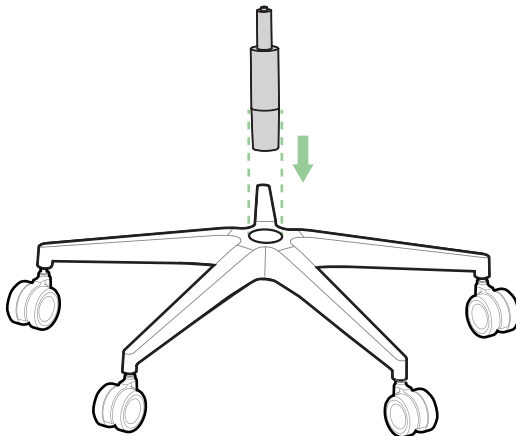
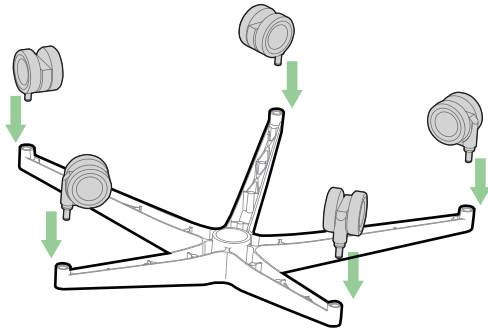

- 1 Install the Casters.**
Insert the 5 *Casters* into the *Wheel Base*.
Push firmly to lock them into place.

- 2 Install The Gas Lift.**
Position the *Gas Lift* into the *Wheel Base*.

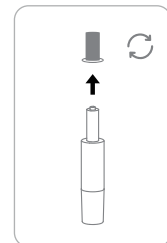

Assembly Process

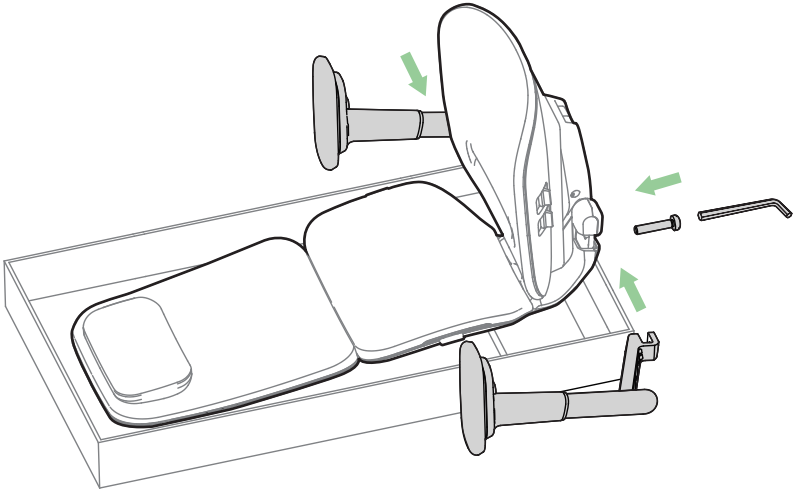

3 Install The Armrests.
Install the chair *Left and Right Armrests*
by *Allen Key* and *MB Screws*.

Assembly Process

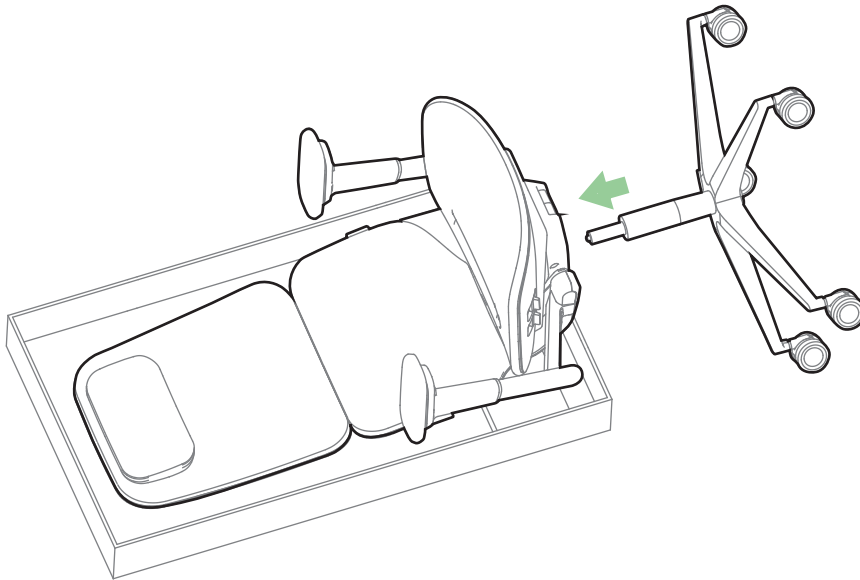

- 4** **Install The Gas Lift and Wheel Base**
Align the top of the *Gas lift* into the bottom of the *Chair Body* Tilt Mechanism. Push to lock it into place.

Assembly Process

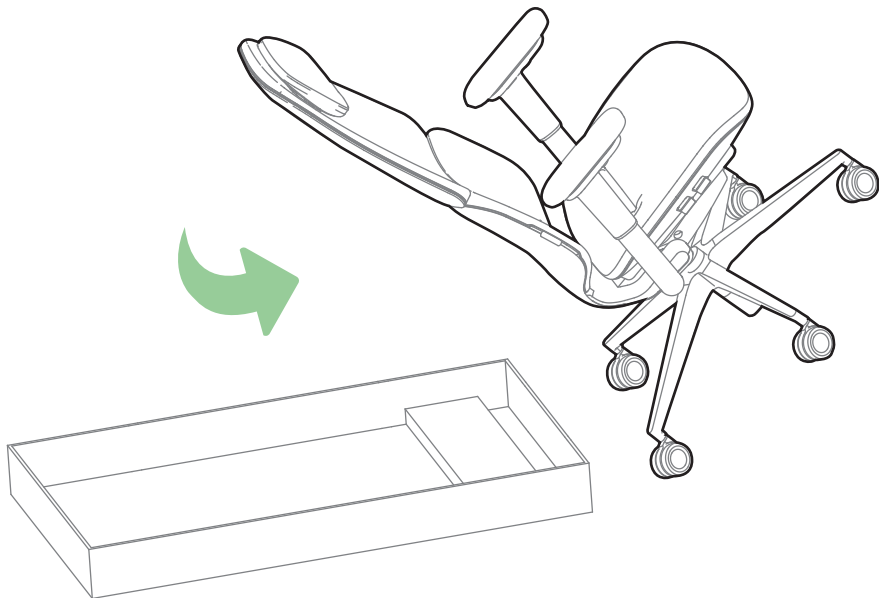

- 5 Flip The Chair Over.**
Installation is complete. Flip the chair over from the ground.

Assembly Process



- 5** **Test And Adjust.**
Adjust the chair settings by following the next chapter: User Guide.

Seat Height Adjustment

Joystick is in front of the right armrest. Release the joystick to lock the height.

Recommendation: Adjusting to the position where your legs are vertical while sitting and your feet are flat on the ground.



Lower

You can angle the joystick without overbending yourself. Height is lower when carrying a weight.

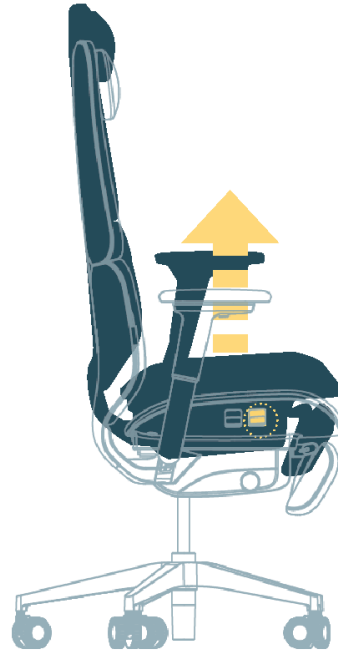

Raise

Angle the joystick then the seat will rise up when not carrying weight.

Lumber Adjustment

Joysticks are located on both sides of the backrest. Adjust the lumbar with both hands at the same time to dynamically fit your back.

WARNING: Do not operate the lumbar support with one hand or adjust it while laying on it to avoid damaging the product.

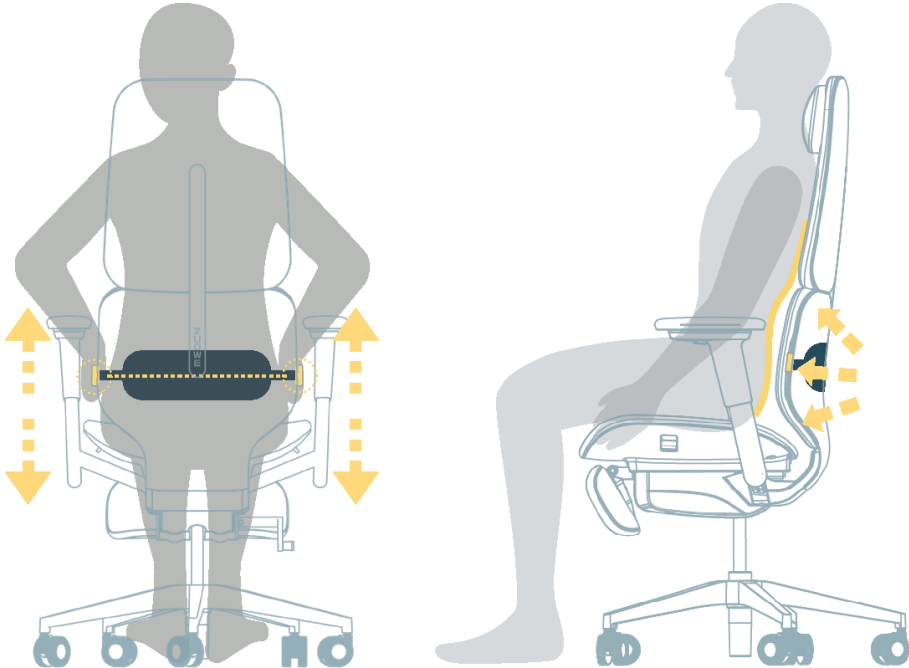

Adjust With Both Hands

Adjusting the height of the lumbar support to a position that can comfortably support the natural curvature of your spine.

Seat Depth Adjustment

Joystick is at the back of right armrest. Lift the joystick, slide the seat forward and backward, you will feel comfortable after long-time sitting.

Recommendation: Adjusting to a position where there is at least 5 cm gaps between the back of the knee and the edge of the seat.

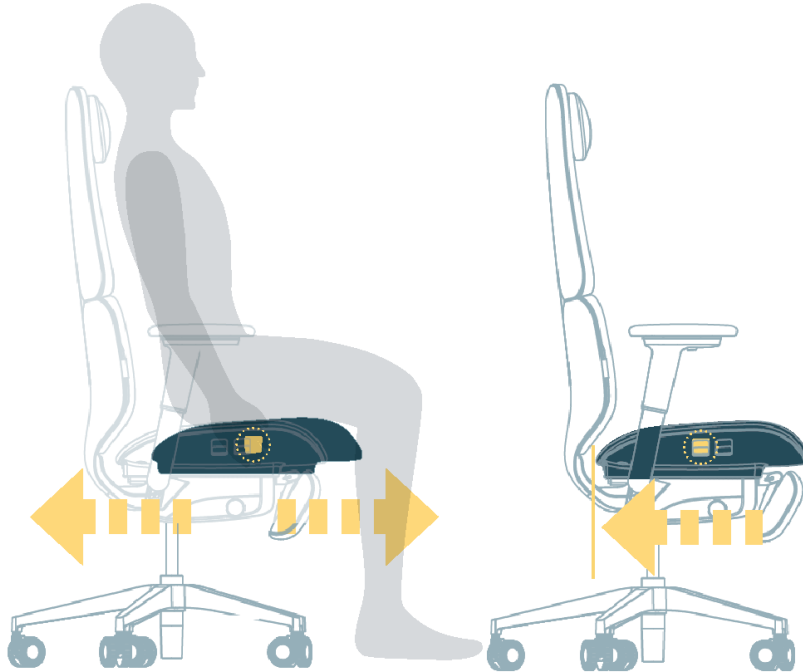

Adjust Seat Depth

Lift the joystick, slide the seat forward and backward

Return

No complicated operations, seat pad return automatically (without weight and joystick unlocked)

Backrest Angle Lock

The joystick is on the left side of the armrest. With the leg rest function (for some models), you can enjoy the zero gravity experience.

Please release the joystick after adjustment.



Adjust Angle

Lean back and adjust the joystick to reach a large elevation angle

Lock

Loosen the joystick to release, smoothly. Repeat the operation and lock the right position

Tilt Tension Control - Model 1

Adjustment handle is at the bottom of the seat pad. You can adjust the back elasticity by rotating the handle in accordance with your weight.

Recommendation: Adjusting to an angle that you can feel resistance when leaning back, but with some difficulty in leaning.

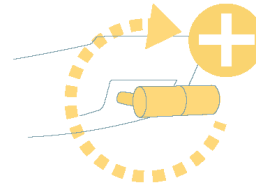
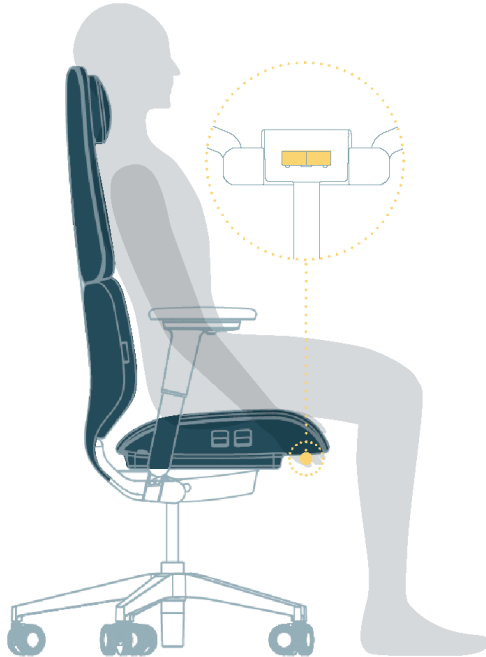

Rotate clockwise to increase elasticity

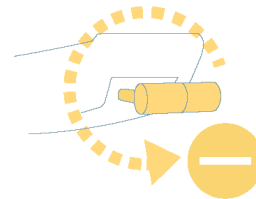

Rotate counterclockwise to reduce elasticity

Pull Out the Handle

Pull out and rotate the handle

Rotate to Adjust

Tilt Tension Control - Model 2

The handle is at the bottom of the right side seat pad. You can adjust the back elasticity by rotating the handle in accordance with your weight.

Recommendation: Adjusting to an angle that you can feel resistance when leaning back, but with some difficulty in leaning.

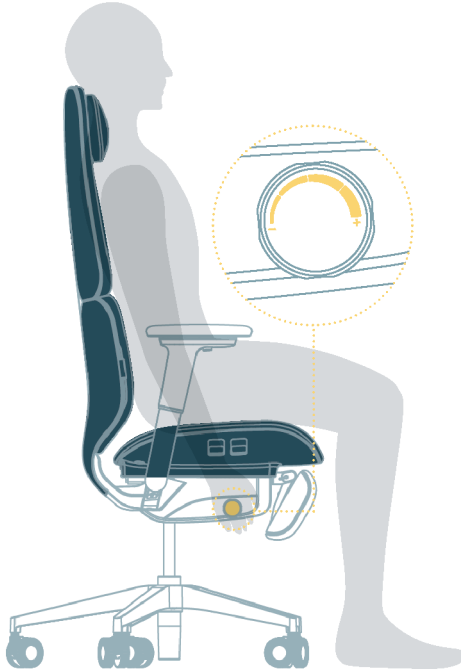

Find the Handle

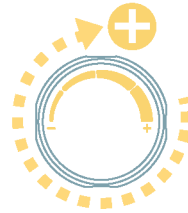

Rotate clockwise to increase elasticity

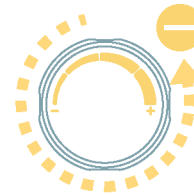

Rotate counterclockwise to reduce elasticity

Rotate to Adjust

Arm Height Adjustment

The bottom is at the bottom of the armrest. Press the button to unlock.

Recommendation: Adjusting to a position where your elbows can touch the surface of armrests when your shoulders are naturally drooping.

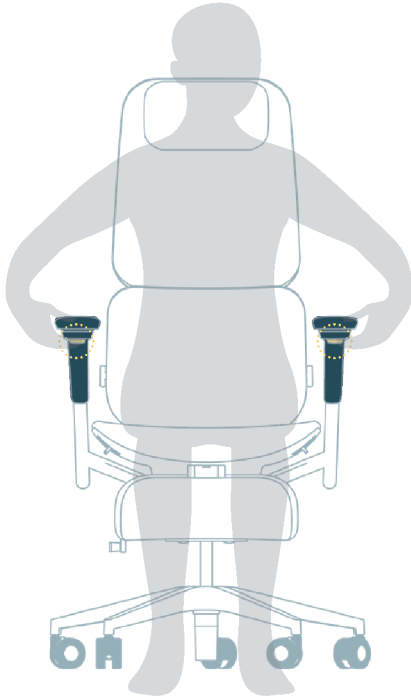

Unlock

Press the button to unlock.

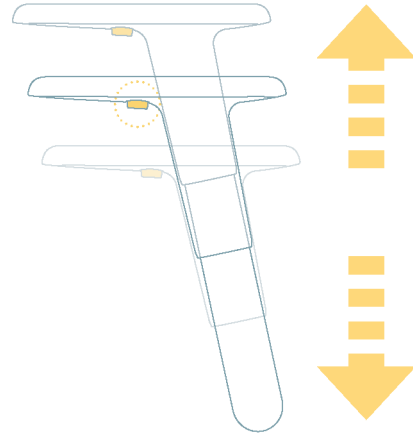

Height Adjustment

Neck Support Adjustment

Multi-dimensional flexible adjustment to fit the neck curve position.

Recommendation: Adjusting to a degree where the head and neck support can carry the neck and shoulders to maintain the position of the cervical spine when naturally bent.

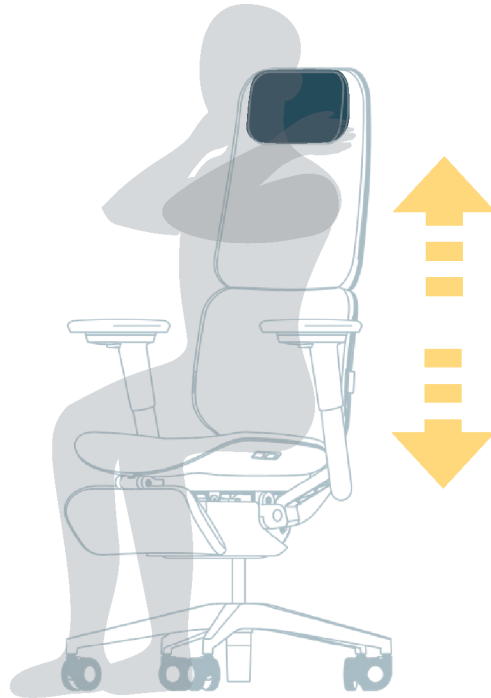

Height Adjustment



Angle Adjustment

Arm Cap Adjustment

You can adjust and rotate the armrest covers to fit your preferred angle.

Recommendation: Adjust the armrest covers to support the hand-elbow-shoulder alignment when sat down.

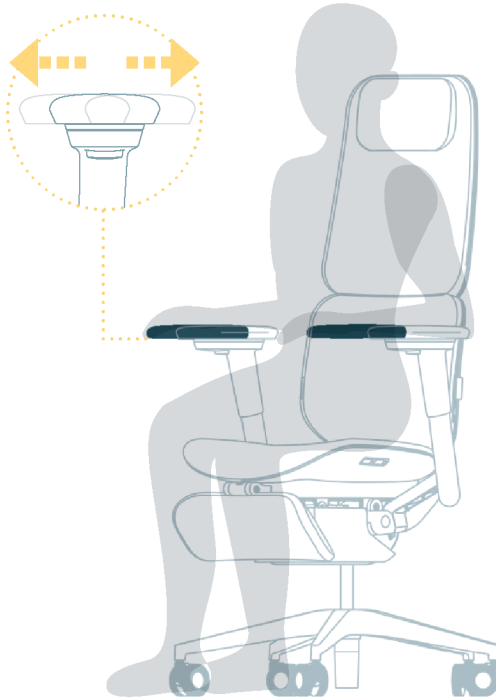

Four Directions

You can directly slide the armrest cover to left and right.

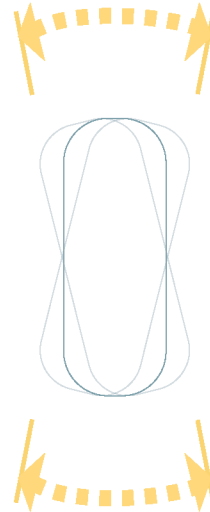

Sliding Adjustment

You can rotate the armrest cover.

Stretchable Leg Support - Some Model

Adjusting the leg support with the angle of the backrest will provide the best body support and lead to a comfortable experience.

Recommendation: Adjusting to a position where the leg rest can support your calf.

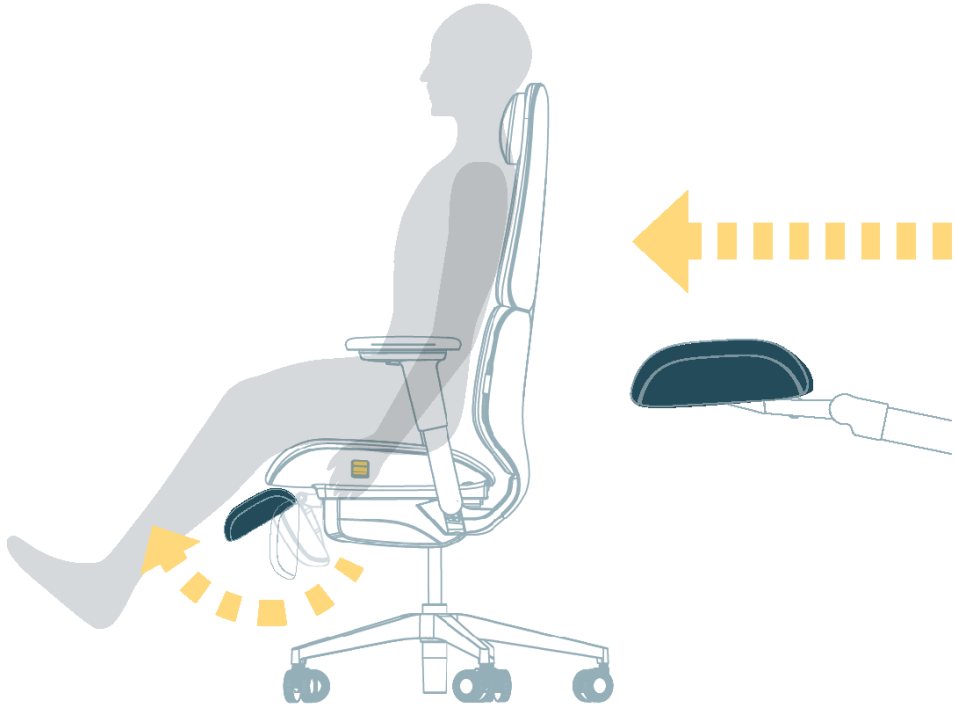

Flip Up

Pull

Pull to a suitable position

Maintenance

With regular care and maintenance, HEXCAL product is able to provide many years of superior performance. To maintain the quality and satisfaction of HEXCAL product, please follow the cleaning procedures as followed:

When in use:

- Do not touch it with blades or sharp objects.
- Avoid long-term direct sunlight or high-energy spotlights, otherwise it may cause the color of some parts to change and affect the appearance of the product.
- Please regularly check whether the moving parts are flexible.
- Please clean the caster shaft attachment regularly.

When not in use:

- Cover it with a cloth to prevent dust.
- Do not expose to sunlight.
- Do not place it in a damp place.
- Keep it away from fire.

Plastic base, frame and arm caps

Normal cleaning

- 01 Wash surface with a soft cloth soaked in mild detergent and warm water.
- 02 Rinse thoroughly and dry with a soft cloth.

- Do not use solvents or abrasive kitchen cleaners.
- Do not rub too vigorously, or it may damage the surface.

Fabric seatback

Normal cleaning

- Vacuum fabric as needed using an upholstery attachment.
- Do not brush fabric or use a vacuum attachment with a rotary brush.
- Brushing may permanently damage the nap or change the character of the fabric.
- Do not apply water or any liquid solution. Wetting the fabric with any liquid solution may result in permanent damage.

Urgent cleaning

- Immediately soak up the stain with a soft absorbent cloth.
- Do not dry the stain completely otherwise it may set. If the stain remains on the fabric, it will be difficult to remove.

Water-based stains such as coffee, soft drinks, fruit juices or milk

01 Soak up the stain immediately, then use a damp clean cloth or sponge to get rid of the residue. Never use hot water, it will set the stain.

02 Use a water-based cleaner (specifically made for cleaning fabric) or a solution of mild (alkaline) warm soapy water applied to a damp clean cloth or sponge. Do not overly soapy.

03 Work the cleaner into a lather or foam. Avoid scrubbing, for it will damage the fabric.

04 Soak up all remaining solution and use a clean cloth or sponge dipped in cool water to remove the residue.

Oil-based stains such as lipsticks, grease, or salad dressing, etc.

01 Test the cleaning solution on a small, concealed area first, check if there is no spotting, ringing, or damage to the fabric or its dyes, apply the cleaning solution to the soiled area with light, quick strokes. Do not apply excessive water or any liquid solution on the fabric because it may result in permanent damage to the product.

02 Begin at the outside of the stain and work toward the center, being careful not to over-saturate the fabric.

03 Soak up all remaining solution and then use another clean cloth or sponge dipped in cool water to remove the residue.

04 Let fabric fully dry and then vacuum well before using the product.

05 If the size of the stain is big, please refer to professional cleaner.

Leather care and Maintenance

We expect your satisfaction with the comfort, beauty, and luxurious feeling that HEXCAL products provide.

To ensure your satisfactory experience, we use leather that meets our standards for quality and durability.

As with any leather product, there are a few special points that we would like you to pay attention to:

Leather ages well

- Over time, your leather products won't look the same as it does now. The more frequent you use it, the more the natural color will show. These changes are normal and it's part of the leather products' charm.

Imperfect beauty

- With top-quality leather, perfection is not flawless. HEXCAL leather is like any other premium leathers. It has some tiny and subtle markings caused by the healed nicks and cuts that occur during the life of the animals. The unique beauty and character of HEXCAL products lies on such natural markings. These natural markings do not affect the durability of HEXCAL products.
- HEXCAL has strict standards for the acceptance of such natural markings. Different levels of markings are allowed based on how visible the leather is on the product.

Caring for Leather

The leather of HEXCAL is extremely soft, supple, durable and resistant. To keep it that way, it's important to care for your leather as follows:

Normal cleaning

01 Frequent vacuum or dusting with clean and dry cloth. Too much scrubbing may damage the leather.

02 If the leather is soiled, you may wipe with a soft and damp cloth using a lather of any mild soap with lukewarm water. Wipe clean with a damp soft cloth and dry with a clean soft cloth.

Urgent spill treatment

01 Wipe liquid immediately with a clean cloth or sponge, let the leather dry naturally. Too much scrubbing may damage the leather.

02 If further cleaning is needed, sponge the entire surface with lukewarm water, including backrest, and armrest. Let the leather dry naturally, do not use a hair dryer or other heat source to dry.

Stubborn spots and stains

01 Apply a mild, nonabrasive soap solution with a clean, wet sponge. Too much scrubbing may damage the leather.

02 Rinse well and let the leather dry naturally.

Butter, oil, or grease

01 Wipe the leather with a clean and dry cloth and let the remaining oil dissipate into the leather. Do not apply water or try to wash grease spot. Do not use saddle soap, cleaning solvents, oils, furniture polishes, vanishes, abrasive cleaners, detergents, or ammonia on leather, they will damage the finish, causing leather to become sticky and cracked.

02 If the size of the stain is big, please refer to a professional cleaner.

Troubleshooting

Failure	Causes	Solution
Seat cannot lift up	01 The seat cushion is loaded when adjusting the height	Adjust the height when the cushion is empty
	02 The seat cushion has reached the highest level	Please set your preferred height between the highest and lowest range
Seat height cannot be fixed	01 The height control paddle is released	Release the paddle and try again
	02 The gas spring is leaking	Please contact an authorized agent
Seat cannot be lowered	01 The seat cushion is not loaded with enough weight	Please sit in the center of the cushion and try again, or increase the weight and try again
	02 The seat cushion has reached the lowest height	Please choose a height between the highest and lowest height range
The depth of the seat cushion cannot be locked and resets by itself	01 The cushion paddle lock is not fixed	Please fine-tune the cushion front and back to ensure that the paddles is reset
The backrest cannot be tilted or resets by itself	01 Check if the backrest is locked	Please adjust the backrest lock button and try again after unlocking it
	02 The backrest angle is in SAFE mode	Please release the backrest paddle and lean back to release the back rest angle SAFE mode.
	03 The backrest is in the tightest mode	Please adjust the tightness and try again
Casters cannot move freely	01 Check if there is debris entering the caster groove	Please clean the caster
Strange noise when using the seat		Please contact the authorized agent
Cannot adjust the waist support	01 The adjustment is under the leaning state	Lean forward to reduce the pressure on the backrest and try again

Warranty

What is covered

The repair or replacement of your HEXCAL product (at HEXCAL's discretion), if it is found to be defective due to:

- 01 faulty materials
- 02 faulty workmanship
- 03 faulty function

within 2 years of purchase (if any part is no longer available or out of manufacture HEXCAL will replace it with a functional replacement part). This warranty will only be valid if the product is purchased.

What is not covered

HEXCAL does not guarantee the repair or replacement of a product where a defect is the result of:

- 01 Accidental damage or fault caused by negligent use or care, misuse, neglect, careless operation or handling of the product which is not in accordance with this User Manual.
- 02 Use of the product for the purpose other than normal sitting.
- 03 Use of parts not assembled or installed in accordance with the instructions of HEXCAL.
- 04 Use of parts and accessories which are not genuine from HEXCAL or not HEXCAL-certified components.
- 05 Faulty installation (except where installed by HEXCAL).
- 06 Repairs or alterations carried out by parties other than HEXCAL or its authorized agents.
- 07 Normal wear and tear (e.g. Normal scratches on the surface, normal aging of leather and cloth, etc.).

Summary of covered

- 01 The warranty becomes effective as of the date of purchase (or the date of delivery, whichever is later).
- 02 You must provide proof of (both the original and any subsequent) delivery/purchase before any work can be carried out on your HEXCAL product. Without this proof, any work carried out will be chargeable. Keep your receipt or delivery note.
- 03 All work will be carried out by HEXCAL or its authorized agents.
- 04 Any part replaced by HEXCAL will become property of HEXCAL.

The warranty provides benefits which are additional to and do not affect your statutory rights as a customer.

Warnings

For your safety, please read the following warnings carefully.
Keep this manual properly for future reference.

Do not sit on the armrests!

Otherwise, it may cause overturning of the seat or other dangerous conditions that could harm your body.

Do not hang any bags or place any objects on the armrests or the backrest!

So as not to affect the stability of the seat.

Do not jump, stand, kneel and play on the seat!

Otherwise, it may cause overturning of the seat or other dangerous conditions that could harm your body.

Do not operate the lumbar support with one hand!

To avoid damaging the product.

Do not play on the seat!

Do not sit backward!

Do not use the seat by more than one person at the same time!

Multiple users will destroy the stability of the product and cause overturning.

Do not squat, sit, or step on the leg rest!

To avoid overturning the seat and causing harm to your body. The leg rest is only used to support the legs when laying down.

Do not use the seat on uneven grounds!

Do not soak or wash the product in water!

Do not use any part or accessory not provided by HEXCAL!

Do not disassemble the gas spring!

