

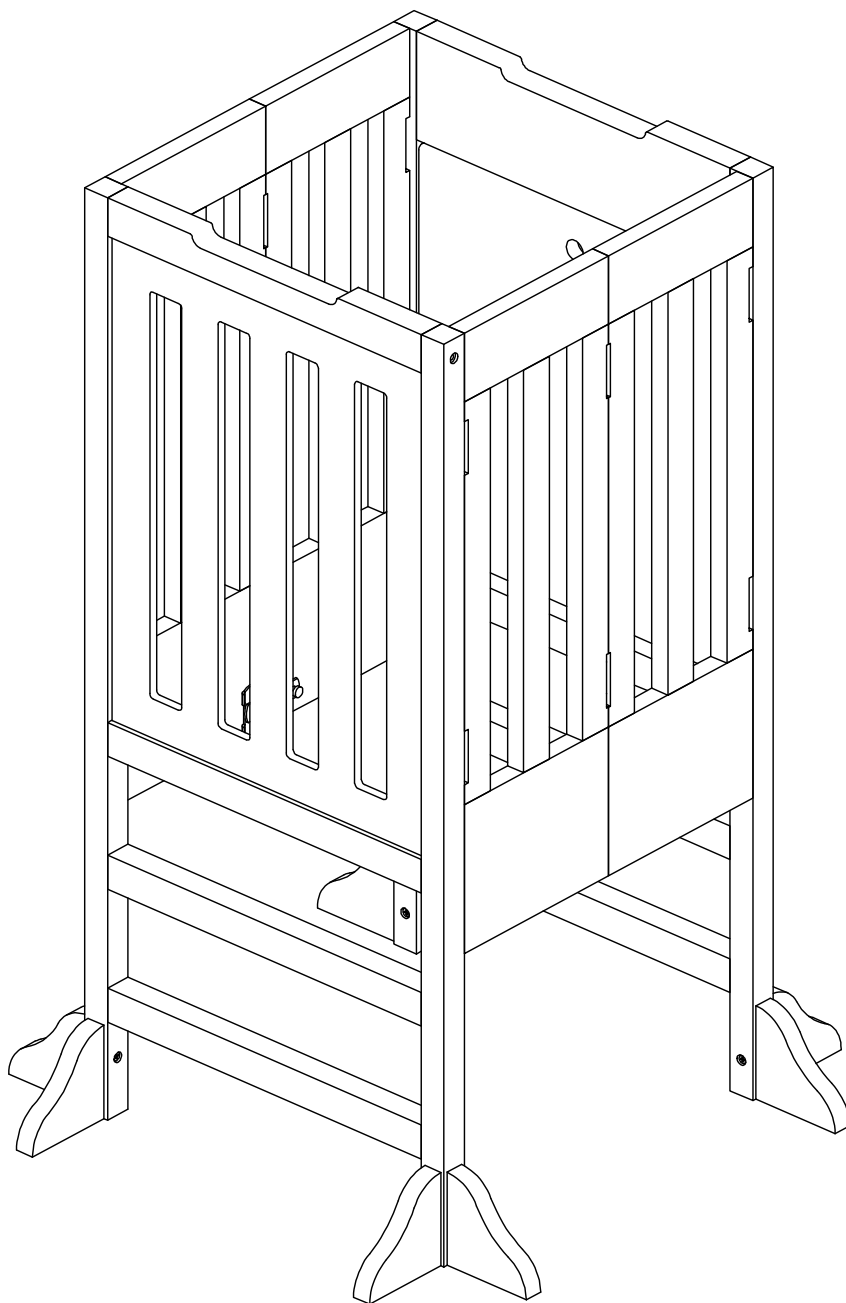

# KITCHEN HELPER

## ASSEMBLY INSTRUCTION



- The manufacturer's assembly instructions must be followed in detail to ensure the safety features to the kitchen helper are not compromise
- To clean surface use only water on a damp cloth. Do not use window cleaners or cleaning abrasives as it will scratch the surface and could damage the protective coating.
- For age 1 to 4 years old. Adult assembly required.

# HARDWARE INVENTORY

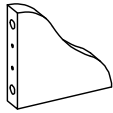
 <p>A. SCREW (8 PCS)</p>	 <p>B. WOOD DOWEL (16 PCS)</p>	 <p>C. LEG SUPPORT (8 PCS)</p>
---	---	---

## STEP 1

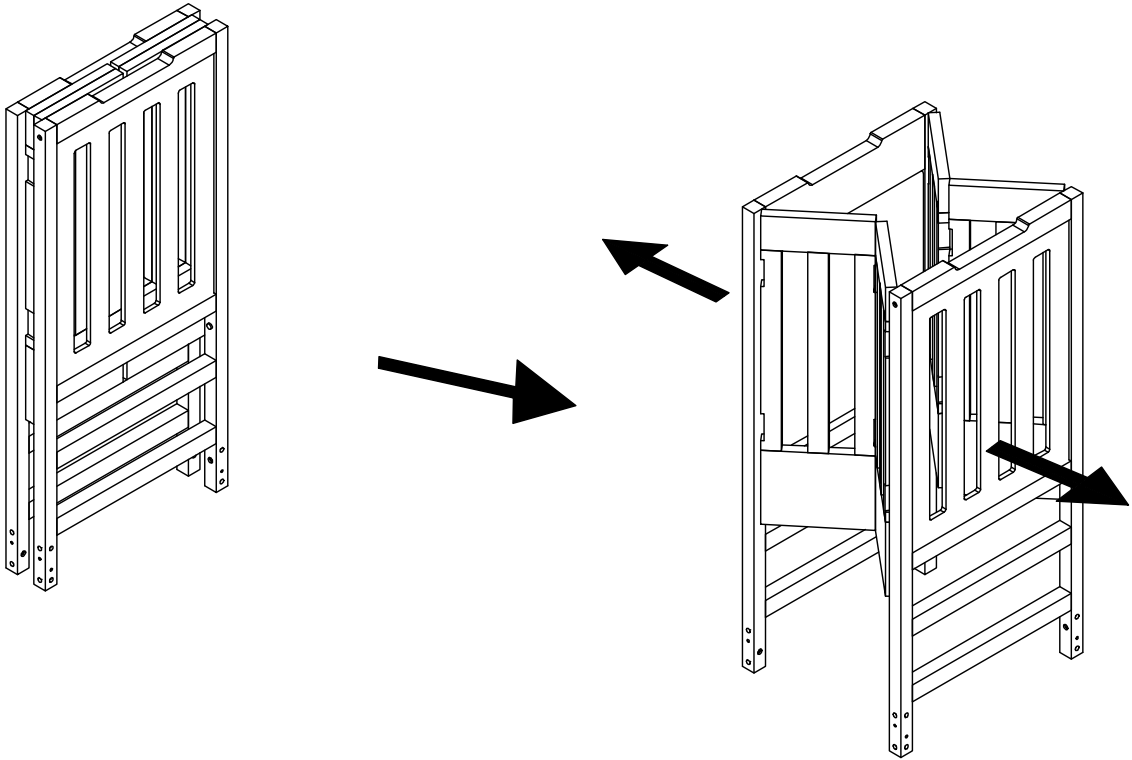

## STEP 2

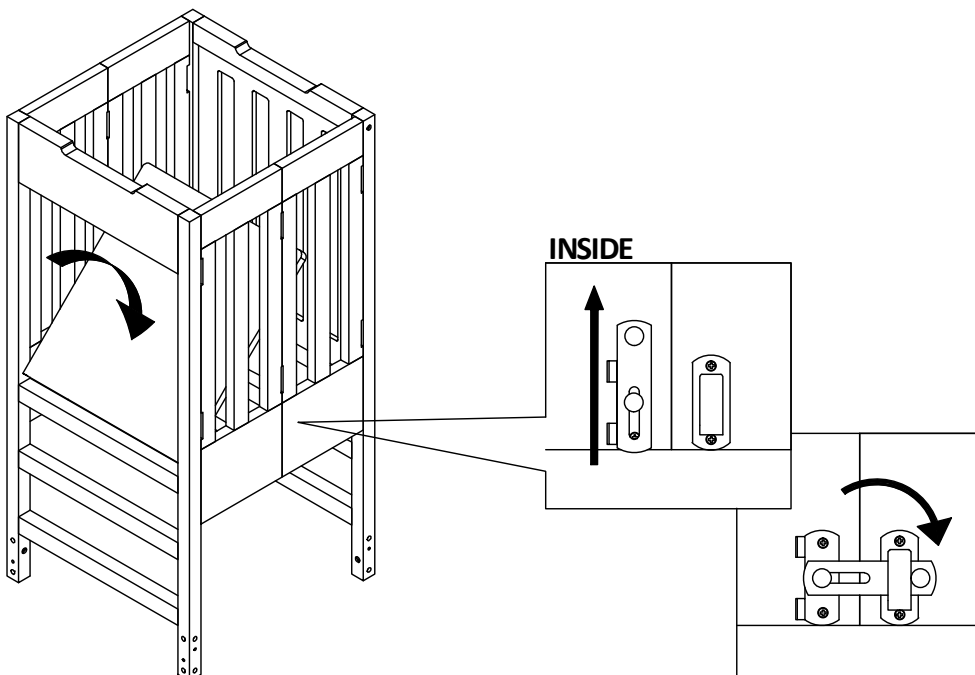

# STEP 3

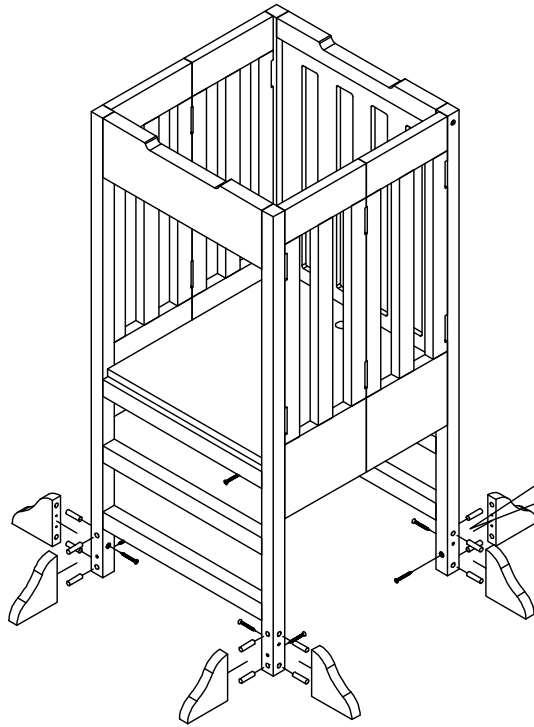

Attach each foot (C) to a leg, making sure that the height of the screw hole on the foot matches the height of the screw hole on the leg

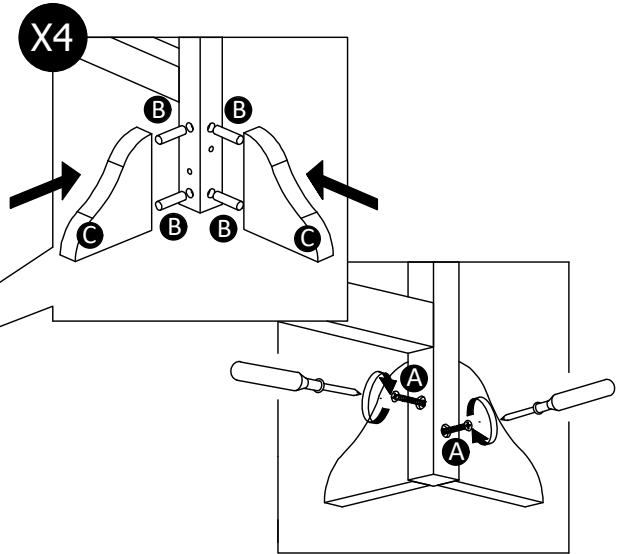

Drill in the screw(A). Repeat for each foot.

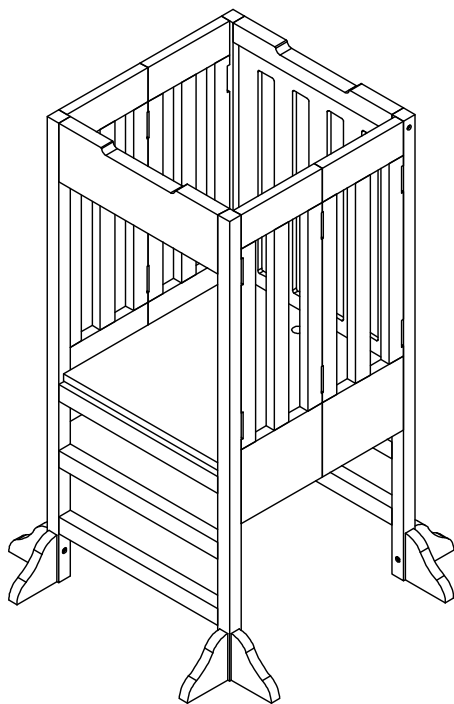

**OPEN**

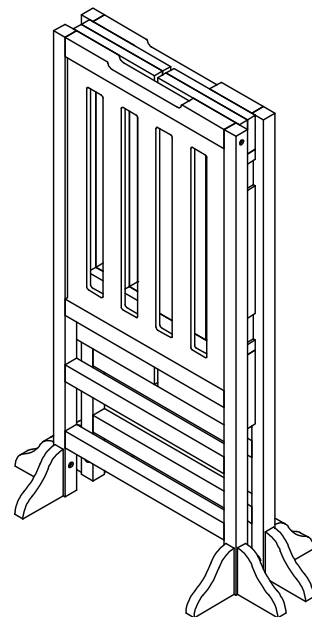

**CLOSE**

# WARNING

READ ALL WARNINGS AND INSTRUCTIONS BEFORE USE. ADULT SUPERVISION REQUIRED.

---

- DO NOT LEAVE CHILD UNATTENDED.
- Keep hot and sharp objects out of reach.
- Make sure Kitchen Helper is fully open and latch is engaged before use.
- Do not allow more than one child on the Kitchen Helper. Maximum user weight 50 lb.
- Do not place any items on the surface to increase standing height.
- Do not allow children to climb on or over the rails, or jump on the Kitchen Helper Place on flat, dry surface.
- Fold and keep out of reach of children when not in use.
- Adult assembly required.