

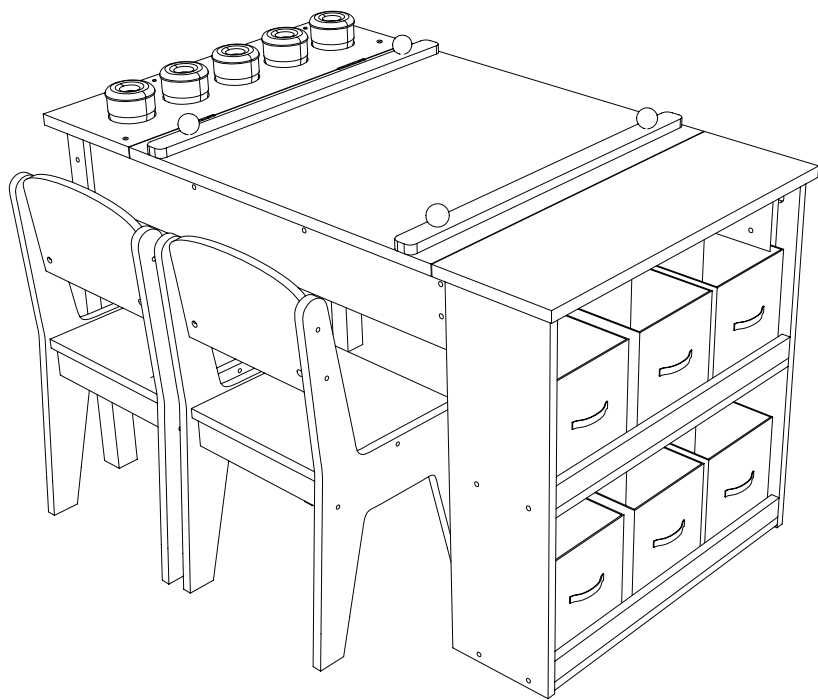

# Art Table

MANUAL



**PRECAUTION:** ALWAYS READ AND FOLLOW INSTRUCTIONS BEFORE USE. ALWAYS USE THE UNIT ACCORDING TO THE MANUFACTURERS GUIDELINES. ONLY USE THE UNIT IN A MANNER AS INTENDED BY MANUFACTURER.

# Welcome to the family!

THANK YOU FOR PURCHASING OUR ART TABLE  
AND TRUSTING MIL LIARD WITH PROVIDING  
YOURSELF AND YOUR LOVED ONES WITH THE UTMOST  
COMFORT AND SUPPORT IN YOUR HOME.  
AS A FAMILY BRAND THAT STARTED BACK IN 2009 WE'VE  
DEDICATED OURSELVES TO CAREFULLY CRAFTING LINES  
OF PRODUCTS TO ELEVATE YOUR HOME. QUALITY  
AND FAIR PRICING IS OUR PROMISE TO YOU.  
IF IT'S NOT GOOD ENOUGH FOR OUR HOME,  
IT'S NOT GOOD ENOUGH FOR YOURS.

**⚠ WARNING:** CHOKING HAZARD - SMALL PARTS NOT FOR CHILDREN UNDER 3 YEARS. THIS PRODUCT IS TO BE ASSEMBLED BY AN ADULT. IN ITS UNASSEMBLED STATE THIS PRODUCT CONTAINS POTENTIALLY HAZARDOUS SHARP POINTS, SHARP EDGES, AND SMALL PARTS. KEEP OUT OF REACH OF CHILDREN.  
**DO NOT STAND ON THE ART TABLE DESIGNED FOR USE BY CHILDREN AGES 3-10**



**KEEP HANDS AWAY WHEN THE TABLE TOP IS OPENING OR CLOSING**

DID YOUR UNIT COME WITH ANY DAMAGED OR MISSING PARTS?

# We're here to help.

OUR TEAM OF DEDICATED CUSTOMER CARE PROFESSIONALS ARE READY TO HELP YOU WITH ANY QUESTIONS OR CONCERNS YOU MAY HAVE.

FOR IMMEDIATE ATTENTION, CALL MONDAY-THURSDAY 9:00AM-5:00PM & FRIDAY 9:00AM-1:00PM.

OR YOU CAN LEAVE US A VOICE MESSAGE OR EMAIL, AND WE GUARANTEE YOU WILL HEAR BACK FROM US WITHIN ONE BUSINESS DAY.

PHONE: 866-686-4891

EMAIL: [INFO@MILLIARDBRANDS.COM](mailto:INFO@MILLIARDBRANDS.COM)



**MAINTENANCE:**

**TO KEEP THE UNIT CLEAN, PERIODICALLY DUST AND WIPE IT WITH A DAMP CLOTH. FOR MORE EXTENSIVE CLEANING, USE A MILD CLEANSER AND A SOFT CLOTH.**

DISCLAIMER: MILLIARD™ ASSUMES NO LIABILITY OR RESPONSIBILITY FOR ACCIDENTS OR INJURIES TO PERSONS OR PROPERTIES ASSOCIATED WITH THE IMPROPER USE OF THIS PRODUCT, NOR DOES MILLIARD CONDONE PROHIBITED OR UNLAWFUL USES. THIS PRODUCT MUST BE USED AS DIRECTED AND ALL SAFETY PRECAUTIONS MUST BE FOLLOWED AT ALL TIMES IN ACCORDANCE TO FEDERAL AND LOCAL LAWS OR REGULATIONS. BUYER ASSUMES ALL RISKS AND LIABILITY FROM MISUSE OF THIS PRODUCT AND MILLIARD SHALL NOT BE HELD LIABLE BEYOND THE INITIAL PURCHASE COST OF THE PRODUCT FOR ANY DAMAGES ARISING FROM ITS MISUSE.

# Chair Parts

1

LEFT CHAIR  
SIDE X2

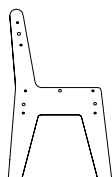

2

RIGHT CHAIR  
SIDE X2

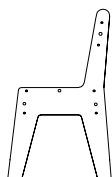

3

SEAT BACK X2



4

SEAT SUPPORT X4

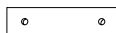

5

SEAT X2

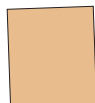

# Table Parts

6

LEFT TABLE LEG X1



7

TABLE END X1



8

RIGHT TABLE LEG X1



9

LEFT SIDE PANEL X1



10

RIGHT SIDE PANEL X1



11

CENTER SUPPORT X1

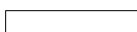

12

EASEL END  
SUPPORT X1

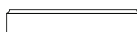

13

TABLE BOTTOM X1



14

SHELF RIGHT  
SIDE X1

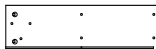

15

SHELF LEFT  
SIDE X1



16

MIDDLE SHELF X1



17

BOTTOM SHELF X1



18

RAILS X2



19

BOTTOM SHELF  
BACK X1



20

TABLE TOP X1

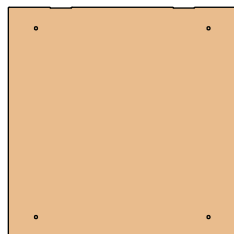

21

SHELF TOP X1



22

UPPER SHELF BACK X1



23

CUP HOLDER  
PANEL X1

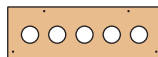

24

CANVAS HOLDER X2



25

ROD X1



26

ROD SUPPORT X2



27

KNOB X4



28

CUP X5



29

STORAGE BIN X6



30

BIN INSERT X6



31

PAPER ROLL X1

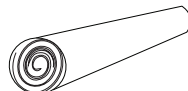

# Hardware Parts

A

DOWEL NUT X40



B

MEDIUM BOLT X34



C

WOODEN DOWEL X32



D

ROUND HEAD SCREW X2



E

LONG BOLT X6



F

FLATHEAD SCREW X6

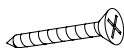

G

CAM NUT X6



H

CAM SCREW X6

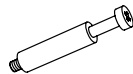

I

SHORT BOLT X6



J

SHORT ROUNDHEAD SCREW X12



K

SHORT FLATHEAD SCREW X16



L

HINGE X2

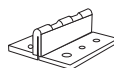

M

PNEUMATIC PISTON X2

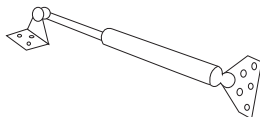

N

HEX KEY X1



# Chair Assembly

## STEP 1

INSERT WOODEN DOWELS (C) INTO EACH OF THE SIX SHALLOW HOLES ON THE LEFT CHAIR SIDE (1).

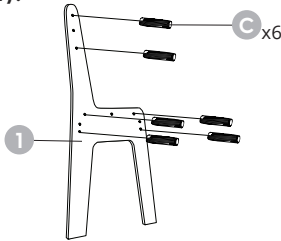

## STEP 2

INSERT A DOWEL NUT (A) INTO THE HOLE ON THE SEAT (5) AND ATTACH IT TO THE LEFT CHAIR (1) SIDE WITH A MEDIUM BOLT (B).

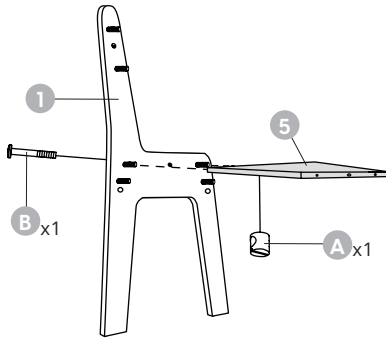

## STEP 3

INSERT DOWEL NUTS (A) INTO THE HOLES ON THE SEAT BACK (3) AND SEAT SUPPORTS (4) AND ATTACH THEM USING MEDIUM BOLTS (B).

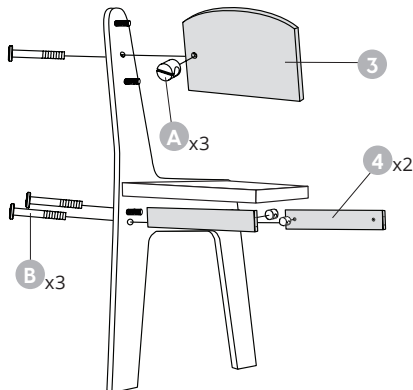

## STEP 4

INSERT WOODEN DOWELS (C) INTO EACH OF THE SIX SHALLOW HOLES ON THE RIGHT CHAIR SIDE (2).

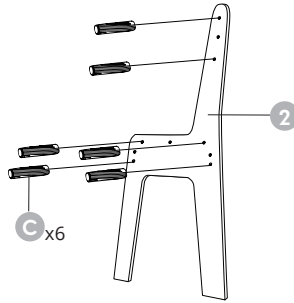

## STEP 5

INSERT DOWEL NUTS (A) INTO THE HOLES OF THE SEAT BACK (3), SEAT (5) AND SEAT SUPPORTS (4) AND ATTACH THE RIGHT CHAIR SIDE (2) WITH MEDIUM BOLTS (B).

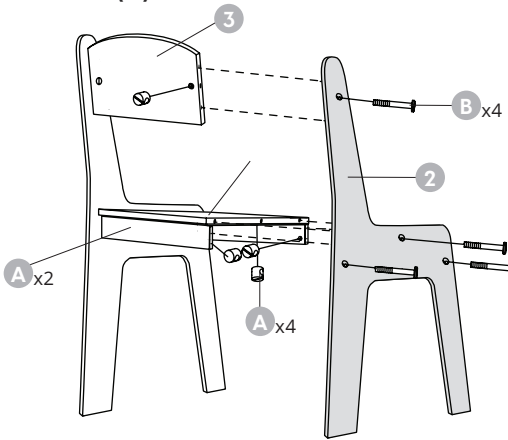

# Art Table Assembly

## STEP 6

- PLACE DOWEL NUTS (A) INTO THE TABLE END (7).
- INSERT WOODEN DOWELS (C) INTO THE SIDES ON THE TABLE END (7).

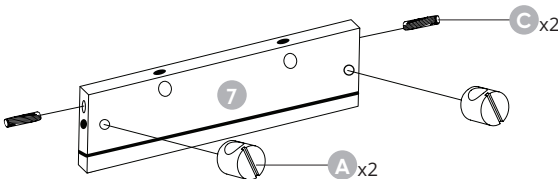

## STEP 7

LET'S ATTACH THE LEFT AND RIGHT TABLE LEGS (6)(8) TO THE TABLE END (7) BY SECURING WITH LONG BOLTS (E).

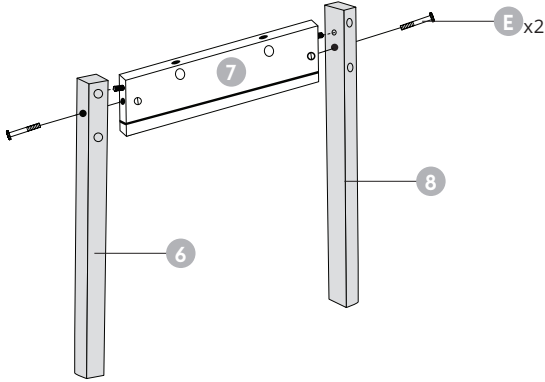

## STEP 8

- PLACE DOWEL NUTS (A) AND WOODEN DOWELS (C) INTO THE CENTER SUPPORT (11).
- INSERT DOWEL NUTS (A) INTO THE EASEL END SUPPORT (12).

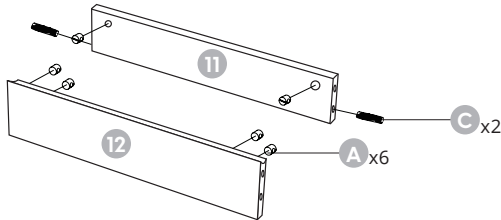

## STEP 9

ATTACH THE LEFT AND RIGHT SIDE PANELS (9)(10) TO THE CENTER SUPPORT (11) AND THE EASEL END SUPPORT (12) USING MEDIUM BOLTS (B).

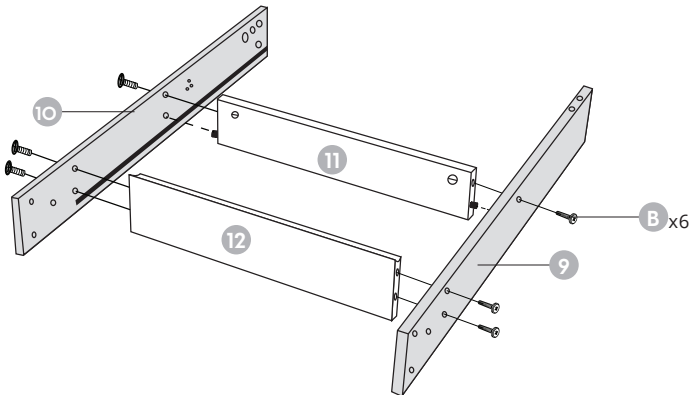



## STEP 10

SLIDE THE TABLE BOTTOM (13) INTO THE SLOTS ON SIDE PANELS (9)(10) UNTIL IT FULLY RESTS IN THE SLOT ON THE EASEL END SUPPORT (12). MAKE SURE THAT THE INDENTED CORNERS ARE FACING THE OPEN SIDE.

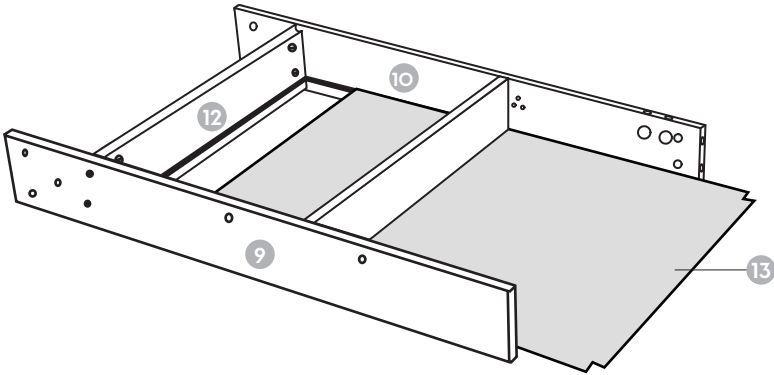

## STEP 11

- INSERT DOWEL NUTS (A) INTO THE SIDE PANELS (9)(10).
- ATTACH, PREVIOUSLY CONSTRUCTED LEGS (6)(7)(8), TO THE TABLE BASE AND SECURE THEM WITH LONG BOLTS (E).

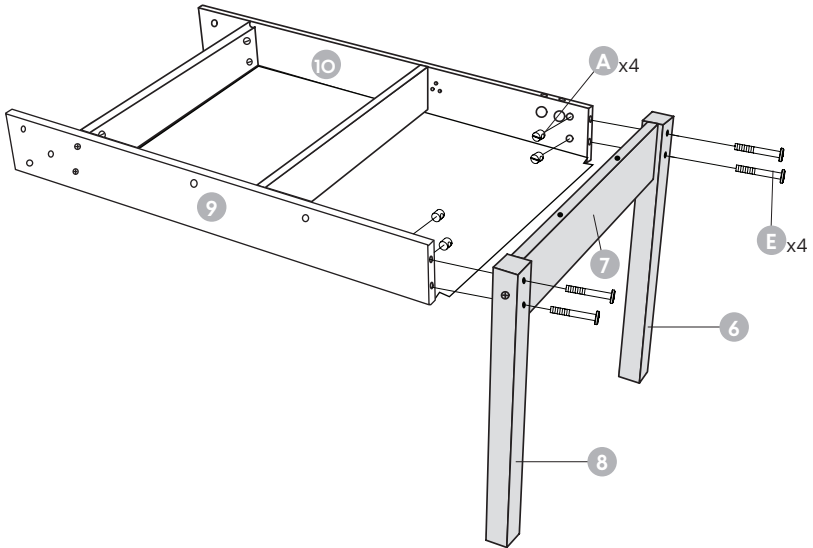

## STEP 12

PLACE DOWEL NUTS (A) INTO THE MIDDLE AND BOTTOM SHELVES (16)(17).

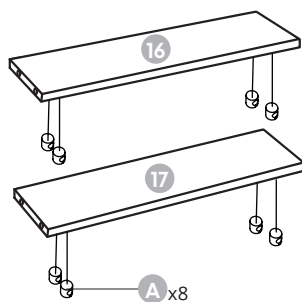

## STEP 13

ATTACH THE RIGHT AND LEFT SHELF SIDES (14)(15) TO THE BOTTOM SHELF (17) USING MEDIUM BOLTS (B).

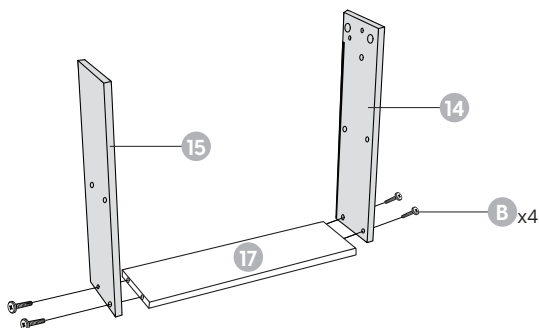

## STEP 14

SLIDE IN THE BOTTOM SHELF BACK (19).

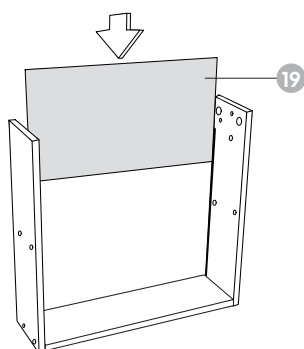

## STEP 15

ATTACH THE MIDDLE SHELF (16) USING MEDIUM BOLTS (B).

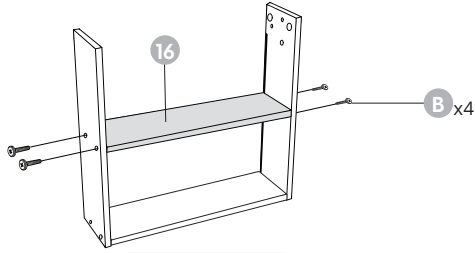

## STEP 16

SLIDE IN THE UPPER SHELF BACK (21).

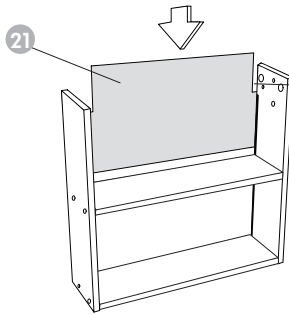

MAKE SURE THAT  
THE INDENTED  
CORNERS ARE  
FACING UP/THE  
OPEN SIDE.

## STEP 17

- INSERT CAM NUTS (G) INTO THE RIGHT AND LEFT SHELF SIDES (14)(15).
- INSERT CAM SCREWS (H) INTO THE SHELF TOP (20).
- ATTACH THE SHELF TOP (20) TO THE SHELF SIDES (14)(15) BY TURNING THE CAM NUTS (G) CLOCKWISE 90 DEGREES.

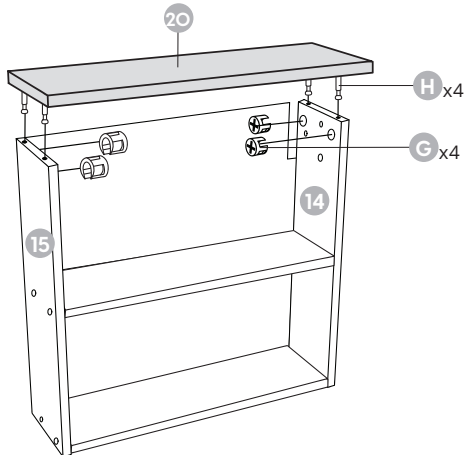

## STEP 18

- TURN THE SHELF UNIT UPSIDE DOWN.
- ATTACH THE RAILS (18) ON TOP OF THE MIDDLE AND BOTTOM SHELVES (16)(17), ON THE FRONT EDGE, WITH FLATHEAD SCREWS (F).

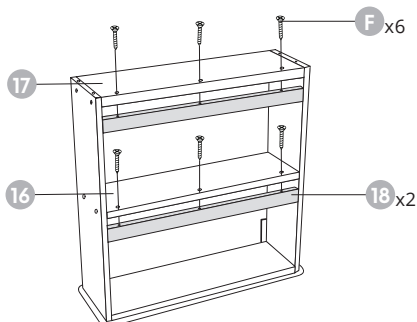

## STEP 19

WITH THE SHELF UNIT STILL UPSIDE-DOWN, INSERT THE PROTRUDING ENDS OF THE PARTIALLY CONSTRUCTED TABLE THROUGH THE OPENINGS IN THE BACK OF THE SHELF UNIT AND SECURE WITH SHORT BOLTS (I) ON EACH SIDE AS SHOWN.

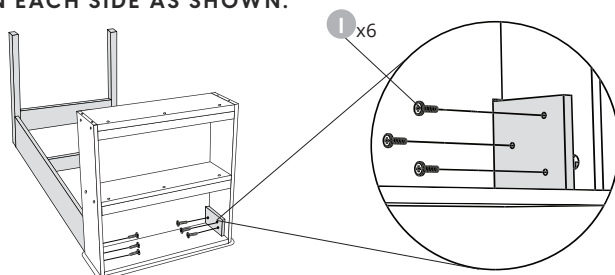

## STEP 20

- ATTACH THE TABLE TOP (22) TO THE CUP HOLDER PANEL (23) BY INSERTING SMALL SCREWS (J) INTO EACH HINGE (L).
- ON THE TABLE TOP (22), INSERT CAM SCREWS (H) INTO EACH MIDDLE HOLE AND WOODEN DOWELS (C) IN THE OUTER HOLES.

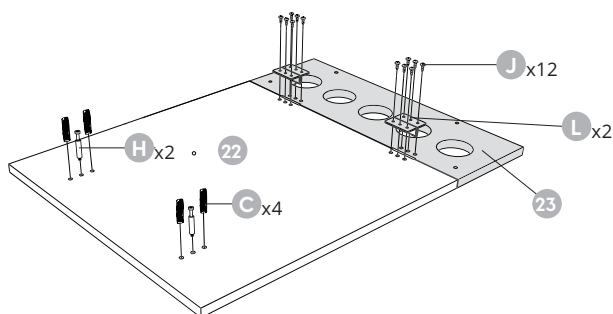

## STEP 21

INSERT A CAM NUT (G) INTO THE SMALLER HOLE ON ONE OF THE ROD SUPPORTS (26) AND SECURE IT TO THE TABLE TOP (22) BY TURNING THE CAM NUT (G) CLOCKWISE 90 DEGREES.

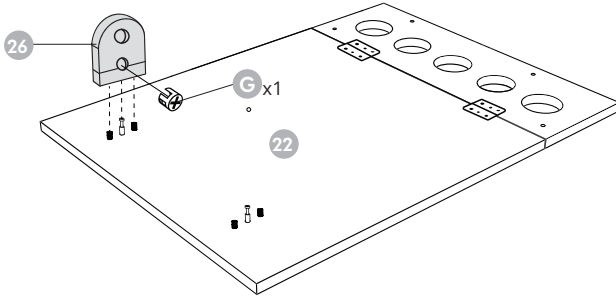

## STEP 22

- INSERT THE PAPER ROLL (31) ONTO THE ROD (25).
- ATTACH THE ROD (25) TO THE ROD SUPPORT (26) USING A ROUND HEAD SCREW (D).

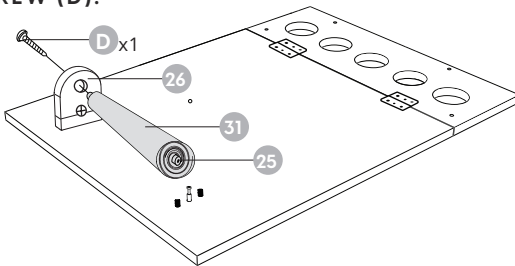

## STEP 23

- ATTACH THE ROD (25) TO THE SECOND ROD SUPPORT (26) USING A ROUND HEAD SCREW (D).
- INSERT A CAM NUT (G) INTO THE OTHER ROD SUPPORT (26) AND SECURE IT TO THE TABLE TOP (22) BY TURNING THE CAM NUT (G) CLOCKWISE 90 DEGREES.

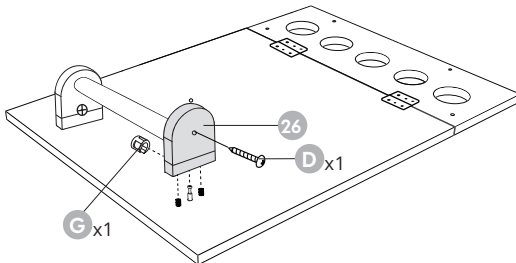

## STEP 24

INSERT DOWEL NUTS (A) INTO THE HOLES ON THE TABLE SIDE PANELS (7)(9)(10) AND SECURE THE CUP HOLDER (23) USING MEDIUM BOLTS (B).

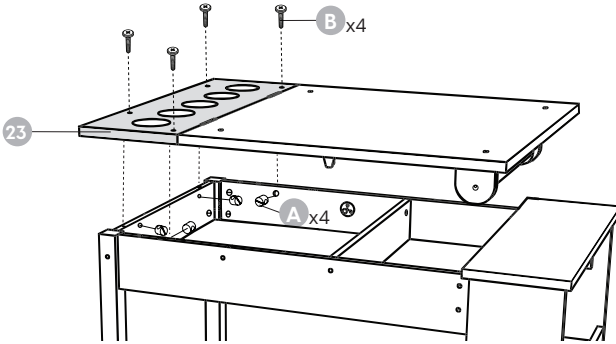

## STEP 25

ATTACH THE PROTRUDING SIDE OF THE PNEUMATIC PISTONS (M) TO THE UNDERSIDE OF THE DESKTOP (22) WITH SHORT FLATHEAD SCREWS (K).

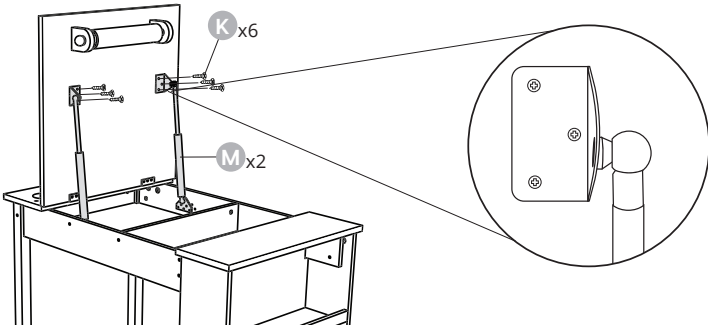

## STEP 26

ATTACH THE FLAT SIDE OF THE PNEUMATIC PISTONS (M) TO THE INSIDE OF THE SIDE PANELS (9)(10) WITH SHORT FLATHEAD SCREWS (K).

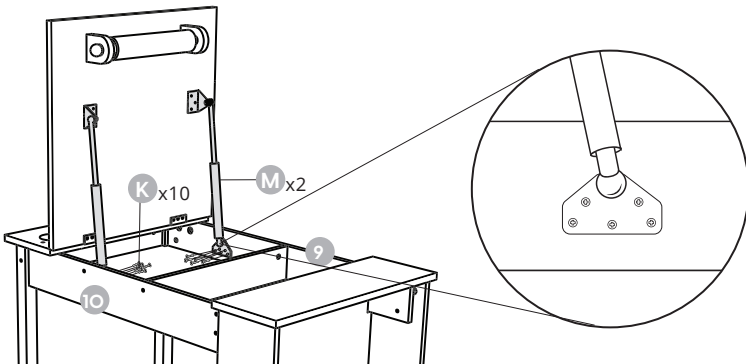

## STEP 27

GENTLY ATTACH THE CANVAS HOLDER STRIPS (24) TO THE TABLE TOP (22) WITH THE KNOBS (27).

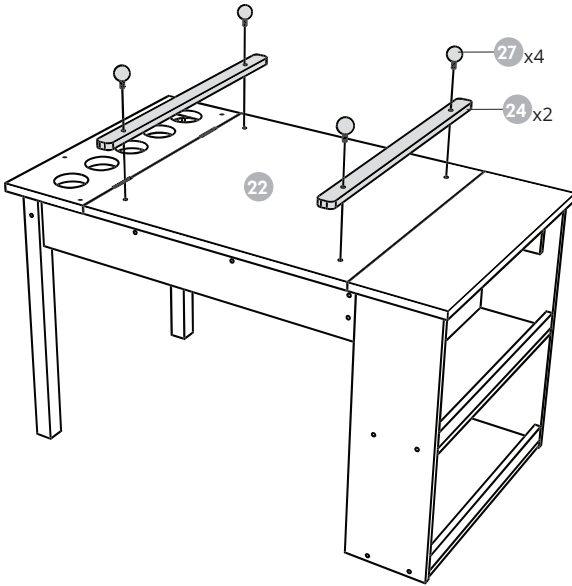

## STEP 28

- FINALLY, PLACE THE CUPS (28) IN THE CUP HOLDERS.
- INSERT THE BIN INSERTS (30) INTO THE BINS (29) AND PLACE THE BINS ONTO THE STORAGE SHELVES.

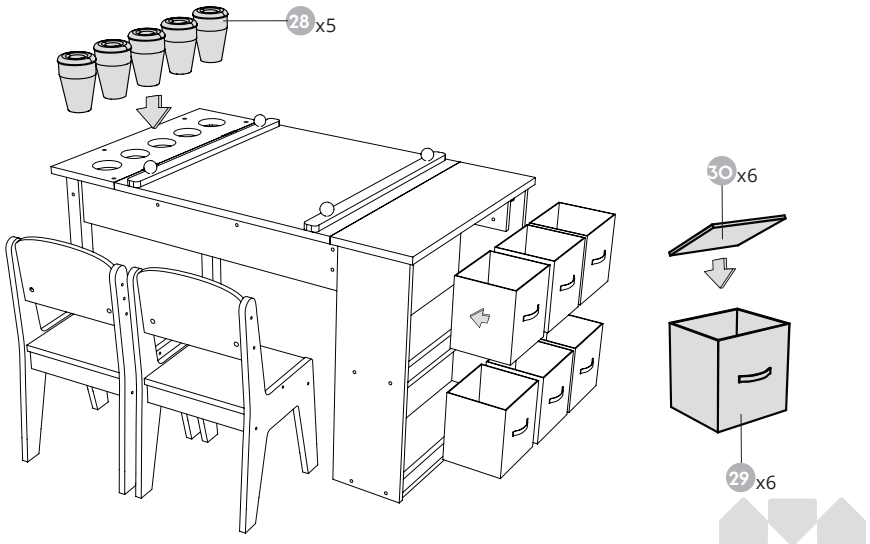

# Thank you again!

YOU'VE OFFICIALLY COMPLETED ALL ASSEMBLING.

THANK YOU AGAIN FOR YOUR PURCHASE.

WE HOPE YOU'RE LOVING IT!



PHONE: 866-686-4891 EMAIL: [INFO@MILLIARDBRANDS.COM](mailto:INFO@MILLIARDBRANDS.COM)