

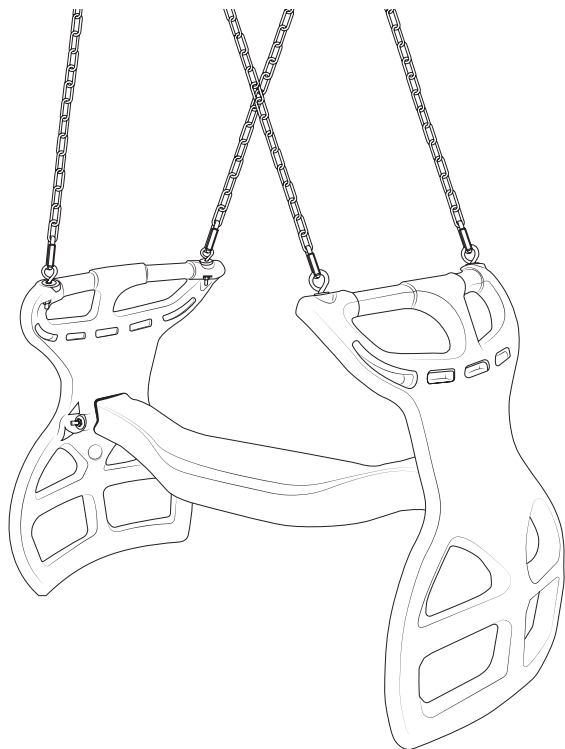

Glider Swing

MANUAL



PRECAUTION: ALWAYS READ AND FOLLOW INSTRUCTIONS BEFORE USE. ALWAYS USE THE UNIT ACCORDING TO THE MANUFACTURERS GUIDELINES. ONLY USE THE UNIT IN A MANNER AS INTENDED BY MANUFACTURER.

Welcome to the family!

THANK YOU FOR PURCHASING OUR GLIDER SWING
AND TRUSTING MIL LIARD WITH PROVIDING
YOURSELF AND YOUR LOVED ONES WITH THE UTMOST
COMFORT AND SUPPORT IN YOUR HOME.
AS A FAMILY BRAND THAT STARTED BACK IN 2009 WE'VE
DEDICATED OURSELVES TO CAREFULLY CRAFTING LINES
OF PRODUCTS TO ELEVATE YOUR HOME.
QUALITY AND FAIR PRICING IS OUR PROMISE TO YOU.
IF IT'S NOT GOOD ENOUGH FOR OUR HOME,
IT'S NOT GOOD ENOUGH FOR YOURS.

IMPORTANT

READ AND FOLLOW ALL SAFETY INFORMATION AND INSTRUCTIONS BEFORE USING THIS PRODUCT. KEEP FOR FUTURE REFERENCE.

Recommended for children 3+ years. Do not leave child unattended while in use.

CAUTION: Use only under adult supervision
Good safety practices should be followed at all times.
Intended solely for family and domestic use, not for a commercial playground or daycare.
Maximum weight capacity: 500lb

Hanging hardware is included. Do not install the Climbing Rope Swing over concrete, asphalt, packed earth, or any other hard surface. Confirm that the supporting structure is secure, it will support at least 200 pounds, is over level ground, and is no less than 6 ft on all sides from vertical elements.

WARNING! CHOKING HAZARD: SMALL PARTS, NOT FOR CHILDREN UNDER 3 YEARS.

WARNING! MAXIMUM WEIGHT SHOULD NOT EXCEED 500lbs.

WARNING! DO NOT USE WITHOUT ADULT SUPERVISION!

WARNING! SMALL PARTS FOR ASSEMBLY BY AN ADULT.

1. Limit: 1 child per seat.
2. Only for family domestic outdoor use by children 3-8 years old.
3. Dress children appropriately, including wearing well-fitting shoes that fully protect the feet.
4. Instruct children:
 - Avoid swinging empty seats or swings
 - To not swing higher than the hook attachment
 - To get off the swing only after it has completely stopped and to hold the rope until both feet are planted firmly on the ground.
 - Not to walk close to, in front of, behind, or between moving items.

DO NOT walk in front or behind swing while in motion



WARNING

- a) When the assembled swing set is installed according to the instructions, the minimum clearance between the ground surface and the underside of any suspended unit shall be 8 in. (200 mm)
- b) Swing sets containing adjacent swing elements shall be designed so that there is a minimum of 8 in. (205 mm) separating elements that are capable of limited lateral motion (where two or more chains, ropes, or poles are used for suspension)
- c) The minimum distance between suspension points shall be 39.4 in. (1000 mm)
- d) Elements with two or more laterally spaced supports where supports are on both sides of the occupant. Minimum spacing between the outer extremity of the swing element and stationary members shall be 7 in. (180 mm) when measured at a height of 28 in. (710 mm) above the seating surface.

Equipment Layout

- a) The use zone to the front and to the rear of to-fro swings shall be a minimum distance of $2X$ on a line extending 90° (1.57 rad) both front and rear from the longitudinal direction of the suspending beam, where X equals the vertical distance from the top of the protective surfacing to the pivot point of the swing. The total horizontal distance from the front to the rear of the use zone shall be not less than $4X$.
- b) The use for a swing capable of unlimited lateral motion shall be a minimum horizontal distance of $Y+72\text{in.}$ (1829mm) in all directions from the pivot point of the swing, where Y equals the vertical distance between the pivot point and the top of the swing seat or suspended member.
 1. Place the equipment on level ground, not less than 6 ft (1.8 m) from any structure obstruction such as a fence, garage, house, overhanging branches, laundry lines, electrical wires.
 2. Do not install home playground equipment over concrete, asphalt, packed earth, grass, carpet, or any other hard surface. A fall onto a hard surface can result in serious injury or death to the equipment user.
 3. To prevent serious injury, children must not use the equipment until properly installed.
 4. Tighten all hardware.
 - Lubricate all metallic moving parts per manufacturer's instructions.
 - Check all protective coverings on bolts, pipes, edges, and corners. Replace if they are loose, cracked, or missing.
 - Check all moving parts including swing seats, ropes, cables, and chains for wear, rust, or other deterioration. Replace as needed.
 - Check metal parts for rust. If found, sand and repaint using a nonlead-based paint meeting the US requirements.



- Reinstall any plastic parts, such as swing seats or any other items that were removed for the cold season.
- Check all moving parts including swing seats, ropes, cables, and chains for wear, rust, or other deterioration. Replace as needed.
- Remove plastic swing seats and other items as specified by the manufacturer and take indoors or do not use.
- Owners shall be responsible for maintaining the legibility of the warning labels.

5. Be sure to disassemble and dispose of the playground equipment in such a way that no unreasonable hazards will exist at the time the playground equipment is discarded.

6. CAUTION:

- Observing the following statements and warnings reduces the likelihood of serious or fatal injury.
- 2 kids and less than 220 lbs that may safely use the equipment simultaneously,
- Recommending on-site adult supervision for children of 3 years and older.
- Instruct children not to walk close to, in front of, behind, or between moving items.
- Instruct children not to twist swing chains or ropes or loop them over the top support bar since this may reduce the strength of the chain or rope.
- Instruct children to avoid swinging empty seats.
- Teach children to sit in the center of the swings with their full weight on the seats.
- Instruct children not to use the equipment in a manner other than intended.
- Instruct children not to get off equipment while it is in motion.
- Do not allow children to wear inappropriate items, such as but not limited to, loose fitting clothing, hood and neck drawstrings, scarves, cord-connected items, capes and ponchos. These items can cause death by strangulation.
- Instruct children not to climb when the equipment is wet.
- Verify that suspended climbing ropes, chain, or cable are secured at both ends.
- Verify that suspended climbing ropes, chain, or cable cannot be looped back onto itself.
- Instruct children not to attach items to the playground equipment that are not specifically designed for use with the equipment, such as, but not limited to, jump ropes, clothesline, pet leashes, cables and chain as they may cause a strangulation hazard.
- Never add extra length to chain or rope. The chains or ropes provided are the maximum length designed for the swinging element(s).



Use zone with protective surfacing, and the specific depth of corresponding surface material is as follows, please specify:

IMPORTANT SAFETY INFORMATION

CRITICAL FALL HEIGHT

Maximum critical fall height is 6 feet (2m). The obstacle-free safety zone which requires safety surfacing is a perimeter that extends 6 feet (2 meters) out from the unit and at least 12 feet (3.7 meters) in front and back of to-fro swings.

Material	Uncompressed Depth			Compressed Depth
	6" (152mm)	9" (228mm)	12" (304mm)	to 9" (228mm)
Wood Chips	7' (2.13m)	10' (3.05m)	11' (3.35m)	10' (3.05m)
Double-Shredded Bark Mulch	6' (2m)	10' (3.05m)	11' (3.35m)	7' (2.13m)
Engineered Wood Fibers (EWF)	6' (2m)	7' (2.13m)	> 12' (3.66m)	6' (2m)
Fine Sand	5' (1.52m)	5' (1.52m)	9' (2.74m)	5' (1.52m)
Coarse Sand	5' (1.52m)	5' (1.52m)	6' (2m)	4' (1.22m)
Fine Gravel	5' (1.52m)	7' (2.13m)	10' (3.05m)	6' (2m)
Medium Gravel	5' (1.52m)	5' (1.52m)	6' (2m)	5' (1.52m)
Shredded Tires*	10-12' (3.0-3.6m)	N/A	N/A	N/A

* This data is from tests conducted by independent testing laboratories on a 6-inch depth of uncompressed shredded tire samples produced by four manufacturers. The tests reported critical heights, which varied from 10 feet to greater than 12 feet. It is recommended that persons seeking to install shredded tires as a protective surface request test data from the supplier showing the critical height of the material when it was tested in accordance with ASTM F1292.



⚠️ WARNING:

THIS PRODUCT IS TO BE ASSEMBLED BY AN ADULT. IN ITS UNASSEMBLED STATE THIS PRODUCT CONTAINS POTENTIALLY HAZARDOUS SHARP POINTS, SHARP EDGES, AND SMALL PARTS. KEEP OUT OF REACH OF CHILDREN.

DID YOUR UNIT COME WITH ANY DAMAGED OR MISSING PARTS?

We're here to help.

OUR TEAM OF DEDICATED CUSTOMER CARE PROFESSIONALS ARE READY TO HELP YOU WITH ANY QUESTIONS OR CONCERNS YOU MAY HAVE.

FOR IMMEDIATE ATTENTION, CALL MONDAY-THURSDAY 9:00AM-5:00PM & FRIDAY 9:00AM-1:00PM.

OR YOU CAN LEAVE US A VOICE MESSAGE OR EMAIL, AND WE GUARANTEE YOU WILL HEAR BACK FROM US WITHIN ONE BUSINESS DAY.

PHONE: 866-686-4891

EMAIL: INFO@MILLIARDBRANDS.COM



MAINTENANCE:

TO KEEP THE UNIT CLEAN, PERIODICALLY DUST AND WIPE IT WITH A DAMP CLOTH. FOR MORE EXTENSIVE CLEANING, USE A MILD CLEANSER AND A SOFT CLOTH.

DISCLAIMER: MILLIARD™ ASSUMES NO LIABILITY OR RESPONSIBILITY FOR ACCIDENTS OR INJURIES TO PERSONS OR PROPERTIES ASSOCIATED WITH THE IMPROPER USE OF THIS PRODUCT, NOR DOES MILLIARD CONDONE PROHIBITED OR UNLAWFUL USES. THIS PRODUCT MUST BE USED AS DIRECTED AND ALL SAFETY PRECAUTIONS MUST BE FOLLOWED AT ALL TIMES IN ACCORDANCE TO FEDERAL AND LOCAL LAWS OR REGULATIONS. BUYER ASSUMES ALL RISKS AND LIABILITY FROM MISUSE OF THIS PRODUCT AND MILLIARD SHALL NOT BE HELD LIABLE BEYOND THE INITIAL PURCHASE COST OF THE PRODUCT FOR ANY DAMAGES ARISING FROM ITS MISUSE.

Glider Swing Parts



A x2



B x6



C x12

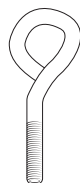

D x4



E x4



F x4

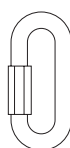

G x4



H x4

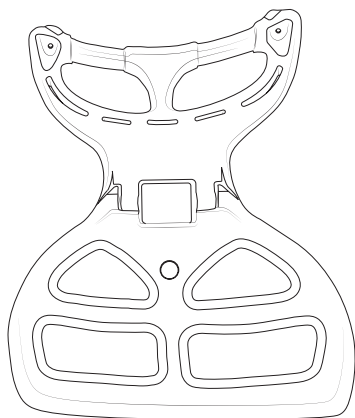

I x2



J x1

Assembly

STEP 1



- INSERT THE SWING SEAT (J) INTO THE NOTCH IN ONE SWING SIDE (I) AND ALIGN THE SCREW HOLES.
- INSERT A SCREW (A) AND WASHER (C) THROUGH THE HOLES AND SECURE THE SCREW WITH A NUT (B) AND WASHER (C).
- REPEAT FOR THE OTHER SIDE.

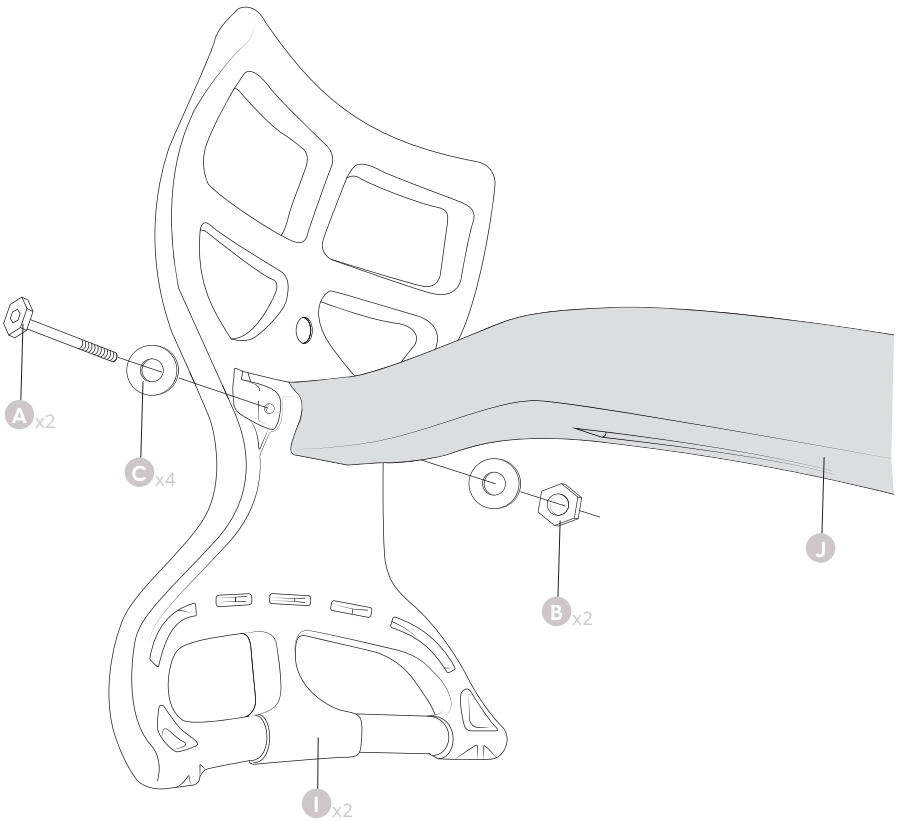

STEP 2

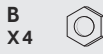

INSERT A RING SCREW (D) WITH A WASHER (C) INTO EACH OF THE 4 TOP HOLES OF THE SWING SIDES (I). SECURE EACH SCREW WITH A NUT (B) AND WASHER (C).

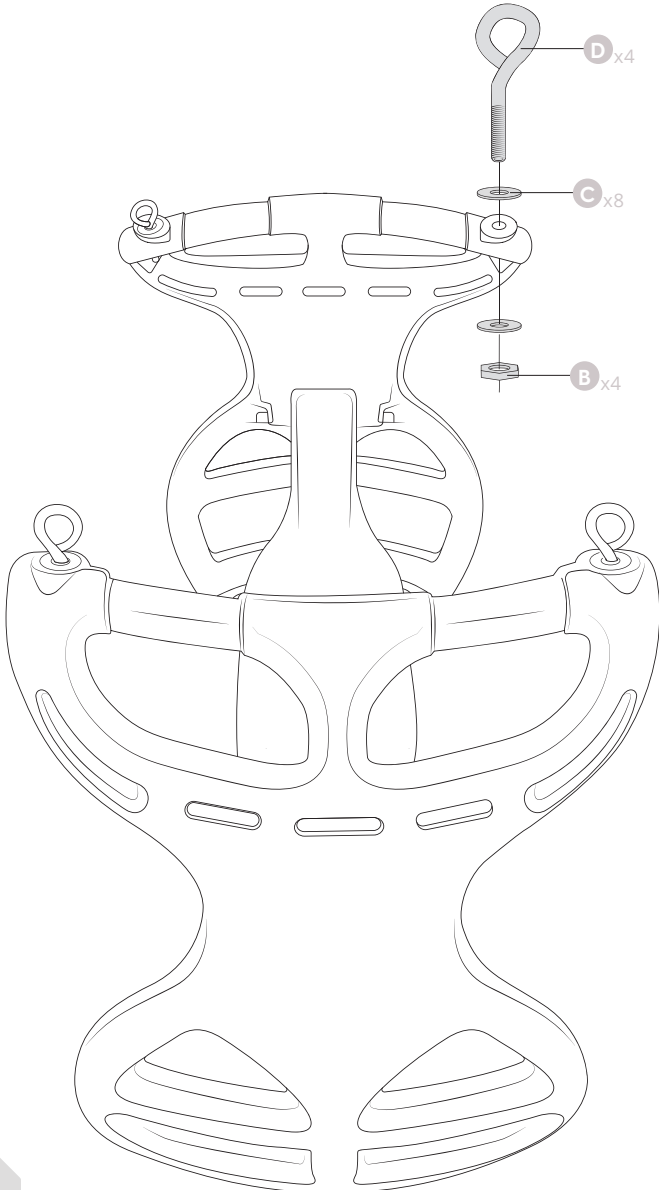

STEP 3

H
x4



G
x4



**ATTACH A SWING CHAIN (H) TO EACH RING HOOK (D) WITH A LOCKING CARABINER (G).
SECURE ALL 4 RINGS TIGHTLY.**

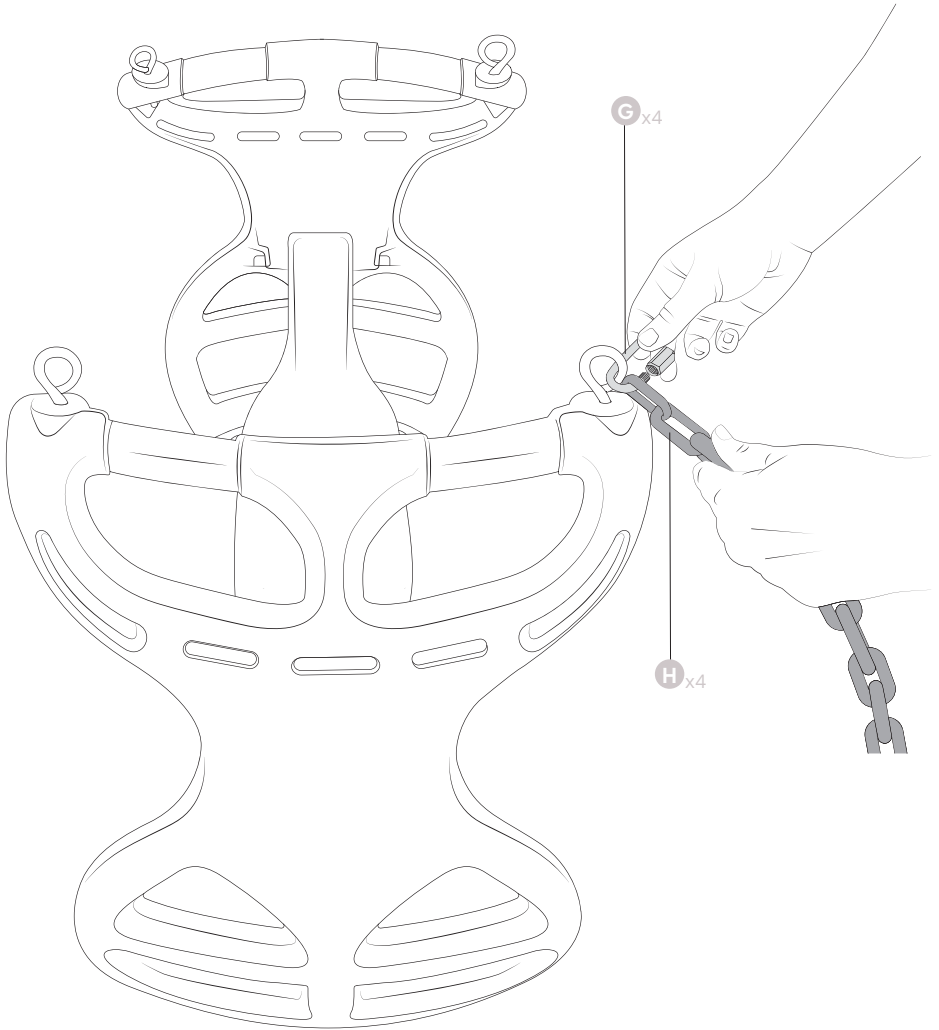

STEP 4



HANGING THE SWING

OPTION A:

- IF THERE ARE NO PREEXISTING HOLES ON THE SWING SET, DRILL A 7.5MM DIAMETER HOLE INTO THE WOOD.
- SCREW IN A SWING HANGER (F) AND REPEAT AT THE OTHER ATTACHMENT POINTS.
- HOOK EACH CHAIN ONTO A SWING HANGER (F).

OPTION B:

- IF THERE ARE ALREADY SWING HOOKS ON THE SWING SET, ATTACH CARABINERS (E).
- HOOK EACH SIDE CHAIN ONTO A CARABINER.

OPTION A

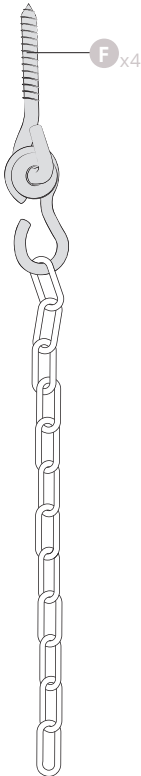

OPTION B

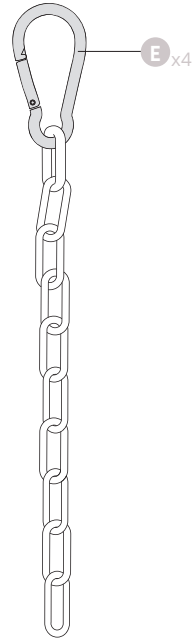

Thank you again!

YOU'VE OFFICIALLY COMPLETED ALL ASSEMBLING.

THANK YOU AGAIN FOR YOUR PURCHASE.

WE HOPE YOU'RE LOVING IT!





PHONE: 866-686-4891 EMAIL: INFO@MILLIARDBRANDS.COM