

M057S D56B14

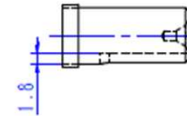
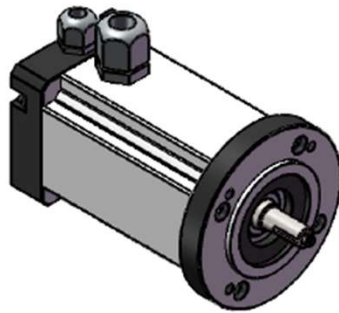
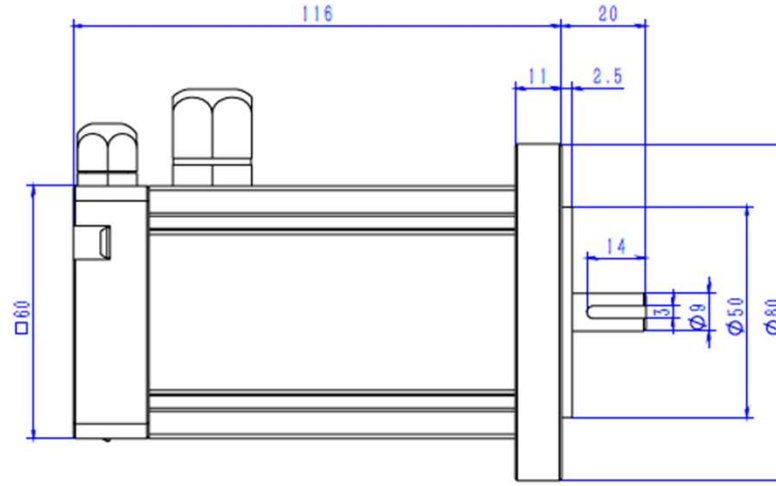
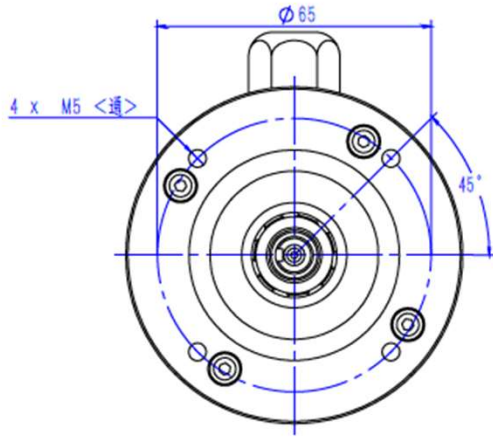

Description: M057 Brushless DC motor with 9mm shaft and 3mm key slot and D56B14 flange (65mm PCD)

Drawing # M057S D56B14
Revision # 1

Drawn By: X.Yan
Date: 21/04/2020

Approved By: C.Matheou
Date: 21/04/2020

Part Number: M057S D56B14

Notes: To suit M057 range of motors.
To suit Size 30 D56B14 right-angle gearbox – flange modification to suit WPL060 planetary gearbox option

