



HAMMERHEAD RANCHER LT



Illustrated Parts Manual

FIG.1

CYLINDER HEAD ASSY.

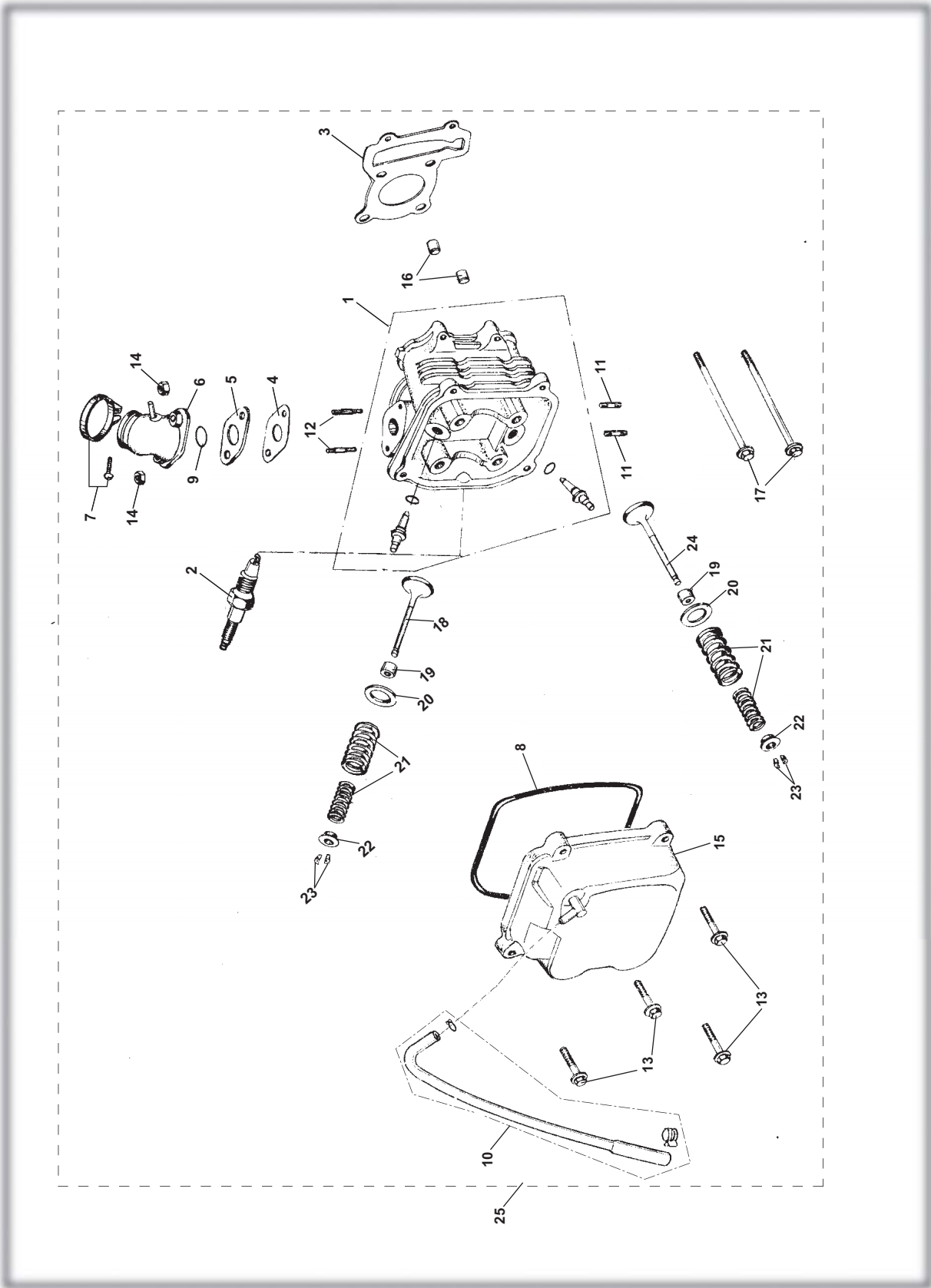

CYLINDER ASSY.

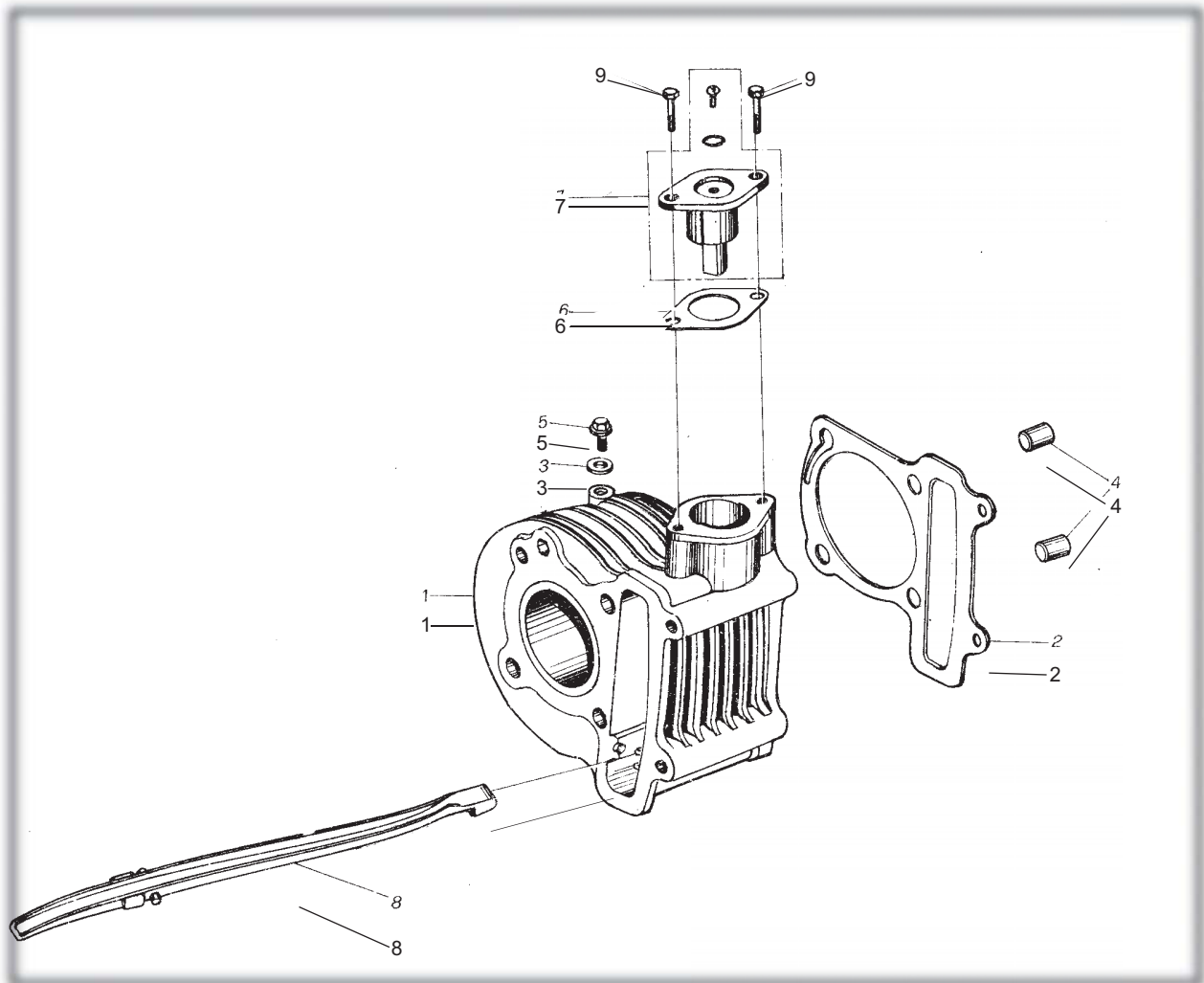

CYLINDER ASSY.				
REF NO.	PART NO.	DESCRIPTION	REGD NO.	
1	M150-1002200	CYLINDER COMP.	1	
2	M150-1002001	CYLINDER GASKET	1	
3	90442-06000-KAT	WASHER SEALING 6	1	
4	M150-1001007	DOWEL PIN 10X16	2	
5	96001-06012-KAT	FLANGE BOLT M6X12-ZN. D	1	
6	M150-1002002	GASKET TENSIONER LIFTER	1	
7	M150-1002100	TENSIONER LIFTER ASSY.	1	
8	M150-1002300	CAM CHAIN GUIDE COMP.	1	
9	96001-06020-KAT	FLANGE BOLT 6X20	2	

Transmission

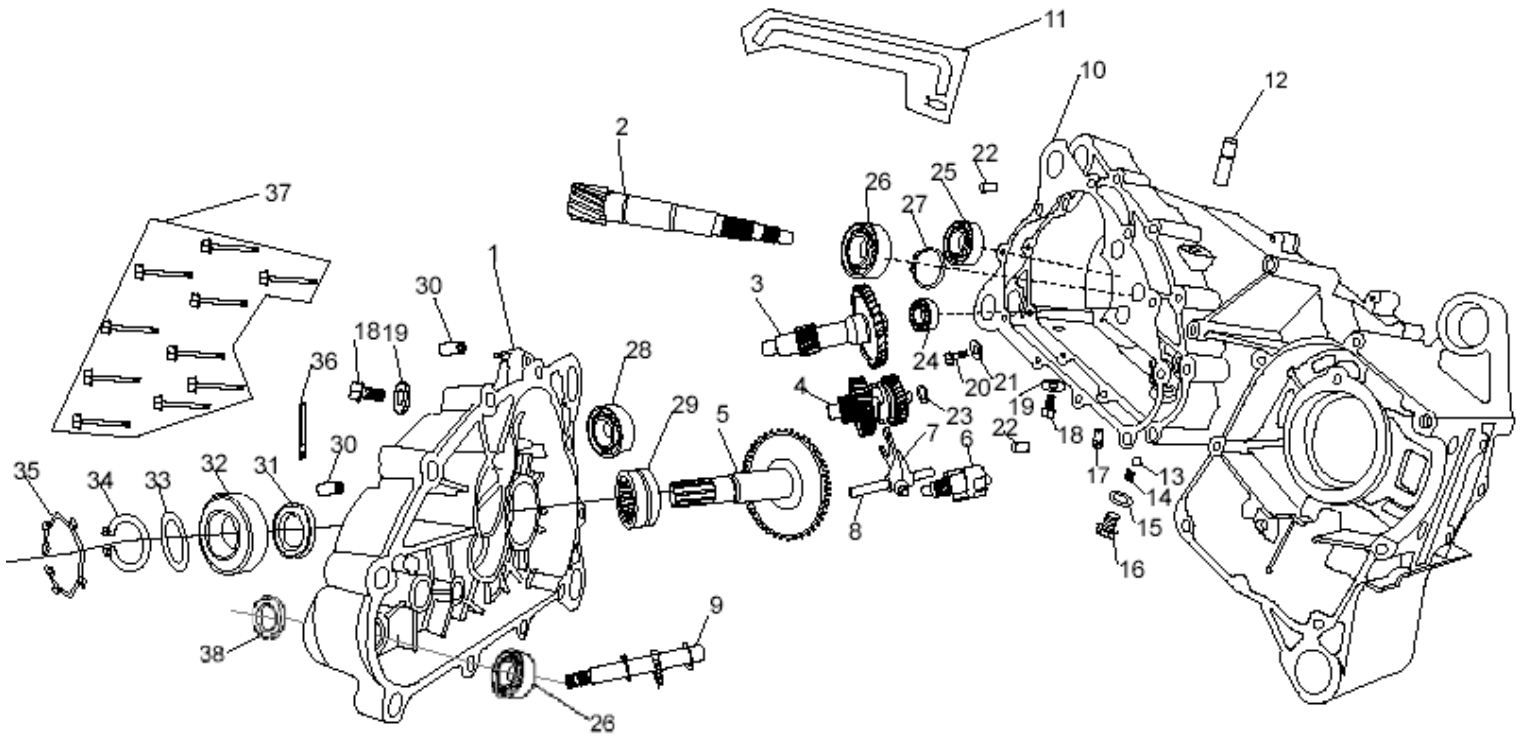

Ref No	Part No	Description	QTY	Ref No	Part No	Description	QTY
1	14297	HOUSING, OUTER TRANSMISSION - 150CC	1	20	14296	BOLT, M6 X 1.00 X 12 FHCS ZN	2
2	14298	GEAR, PRI DRIVE - 150CC	1	21	14315	WASHER, M6 FLAT	2
3	14299	GEAR, SEC DRIVE - 150CC	1	22	14287	PIN, M10 X 14 DOWEL	2
4	14300	ASM, SHIFT GEAR CLUSTER D/N/R - 150CC	1	23	14316	SPACER, M15 INNER GEAR - 150CC	1
5	14841	GEAR, FINAL DRIVE SHAFT - EXT - 200S	1	24	14149	BEARING, OUTER - 6202-Z	1
6	14302	ASM, SHIFT SELECTOR - 150CC	1	25	50102	BEARING BALL RADIAL 6203	1
7	14303	PAWL, SHIFT SELECTOR - 150CC	1	26	14146	BEARING, INNER - 6204-Z	1
8	14304	ROD, SHIFT PAWL - 150CC	1	27	14106	CIRCLIP, M20	1
9	14305	SHAFT, SHIFTER CAM - 150CC	1	28	14503	BEARING, 6302 15 X 42 X 13	1
10	14306	GASKET, TRANSMISSION CASE - 150CC	1	29	14504	BEARING, RNA4905 30 X 42 X 17	1
11	14307	TUBE, TRANSMISSION VENT - 150CC	1	30	14505	BUSHING, SHOCK ABSORBING - 150CC	2
12	14308	NIPPLE, VENT TUBE - 150CC LARGE	1	31	14318	SEAL, M30 X 40 X 6	1
13	14309	BALL, SHIFT INDENT - 150CC	1	32	14598	BEARING, SEALED 6205 - 150CC	1
14	14310	SPRING, SHIFT INDENT - 150CC	1	33	14511	WASHER, M22 X 31 X 2.5 FLAT	1
15	14311	GASKET, SHIFT INDENT - 150CC	1	34	14319	CIRCLIP, M25	1
16	14312	BOLT, SHIFT INDENT - 150CC	1	35	14320	CIRCLIP, M52	1
17	14502	NIPPLE, VENT TUBE - 150CC SMALL	1	36	14321	CLAMP, WIRE - 150CC	1
18	14313	BOLT, DRAIN/FILL PLUG - 150CC	2	37	14235	BOLT, M6 X 1.00 X 40 FHCS ZN	10
19	14314	GASKET, TRANS DRAIN PLUG - 150CC	2	38	14597	OIL SEAL, SHIFTER CAM - 150CC	1

CRANKSHAFT CON'ROD & PISTON ASSY.

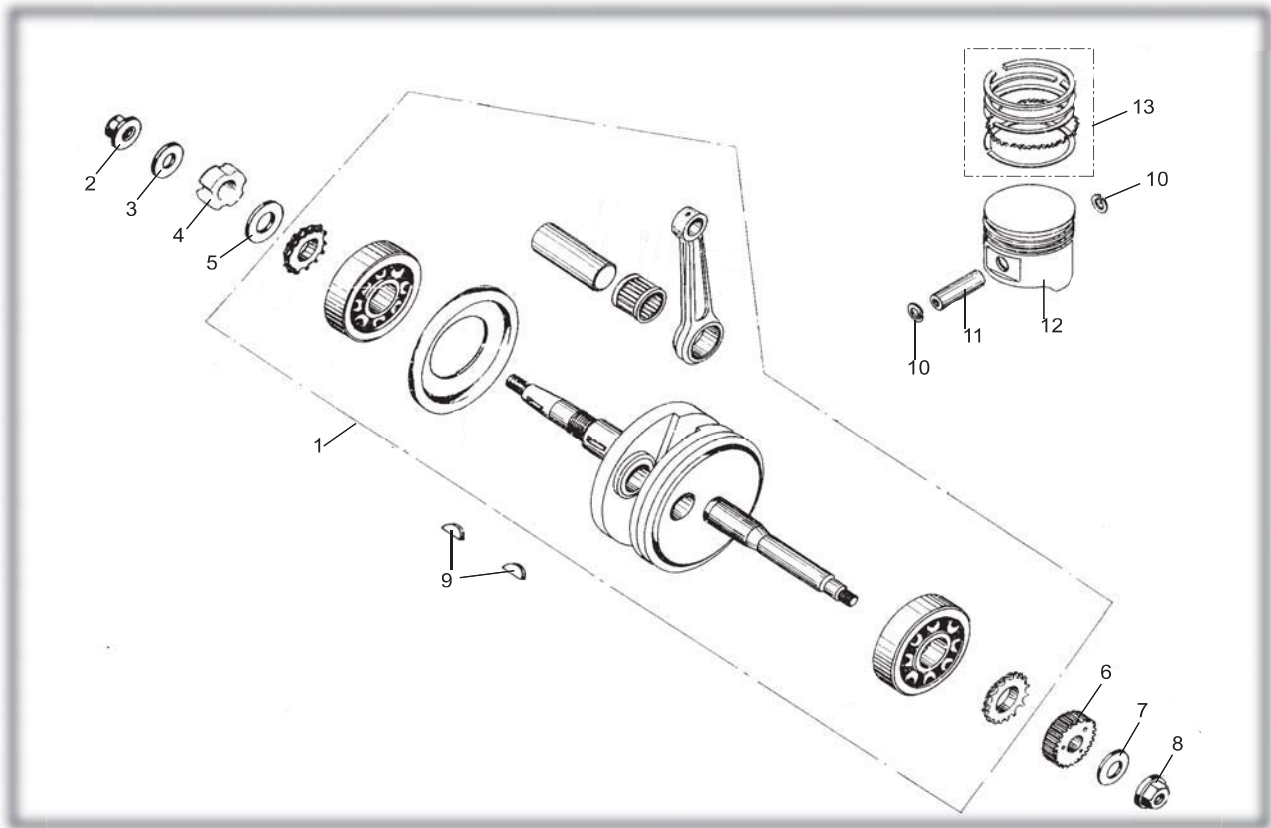

CRANKSHAFT CON'ROD & PISTON ASSY.				
REF NO.	PART NO.	DESCRIPTION	REGD NO.	
1	M150-1004100	CRANKSHAFT & CONROD ASSY.	1	
2	M150-1004007	NUT M12X1.25	1	
3	M150-1004011	WASHER 12-149HV 12-140HV	1	
4	M150-1004009	LOCKING NUT	1	
5	M150-1004013	WASHER	1	
6	M150-1004012	KICK DRIVE GEAR	1	
7	M150-1040005	WASHER $\Phi 12$	1	
8	M150-1004008	NUT M12	1	
9	M150-1004002	WOODRUFF KEY	2	
10	M150-1004003	PISTON PIN CLIP	2	
11	M150-1004006	PISTON PIN	1	
12	M150-1004001	PISTON	1	
13	M150-1004200	PISTON RING SET	1	

CAMSHAFT ASSY.

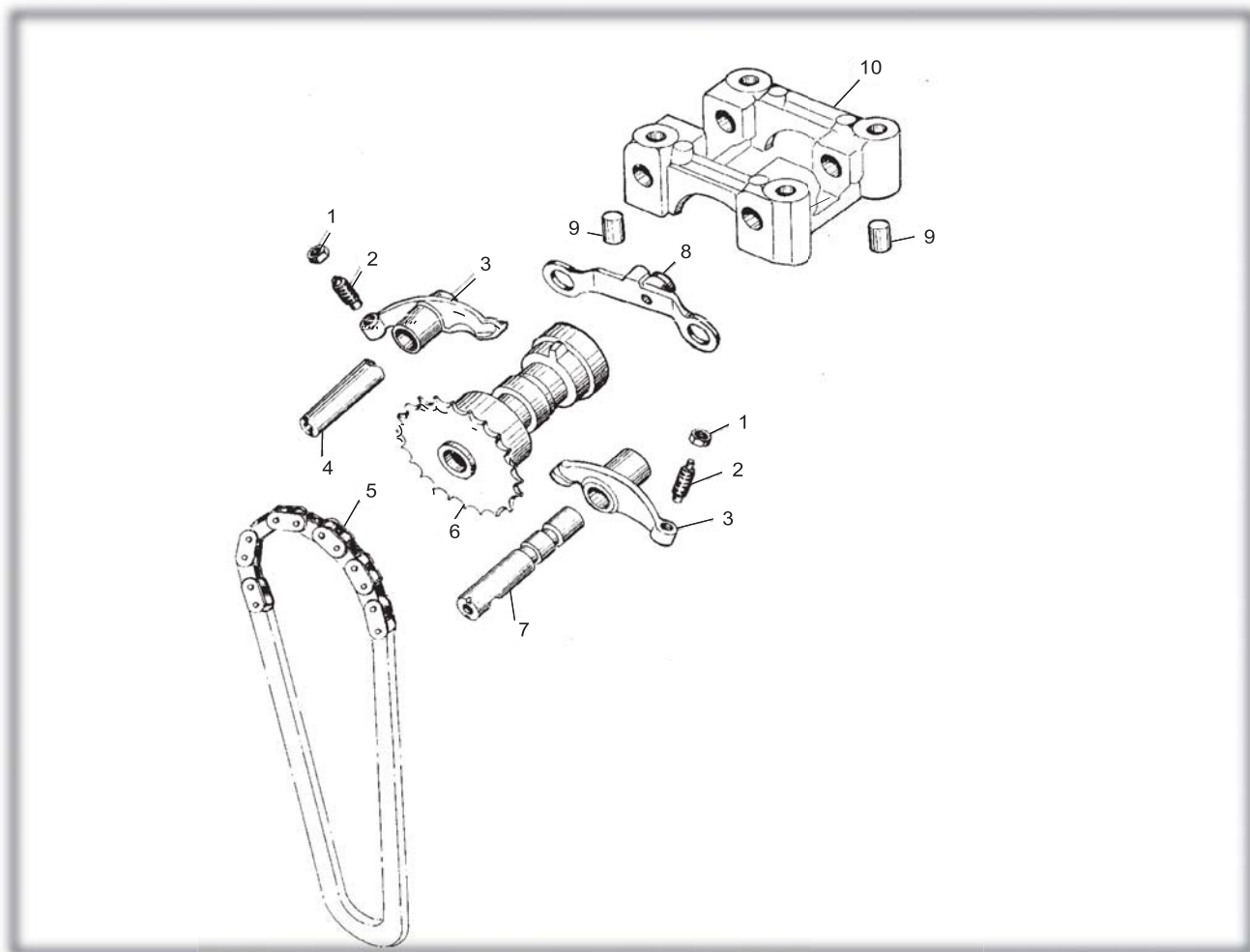

CAMSHAFT ASSY.				
REF NO.	PART NO.	DESCRIPTION	REGD NO.	
1	M150-1005004	TAPPET ADJUSTING NUT	2	
2	M150-1005003	TAPPET ADJUSTING SCREW	2	
3	M150-1005002	VALVE ROCKER ARM	2	
4	M150-1005005	EX ROCKER ARM SHAFT	1	
5	M150-1005400	CAMSHAFT CHAIN	1	
6	M150-1005300	CAMSHAFT COMP. 16T	1	
7	M150-1005200	IN ROCK ARM SHAFT COMP.	1	
8	M150-1005100	STOPPER PLATE COMP.	1	
9	M150-1001007	DOWEL PIN 10X16	2	
10	M150-1005001	CAMSHAFT HOLDER	1	

LEFT COVER ASSY.

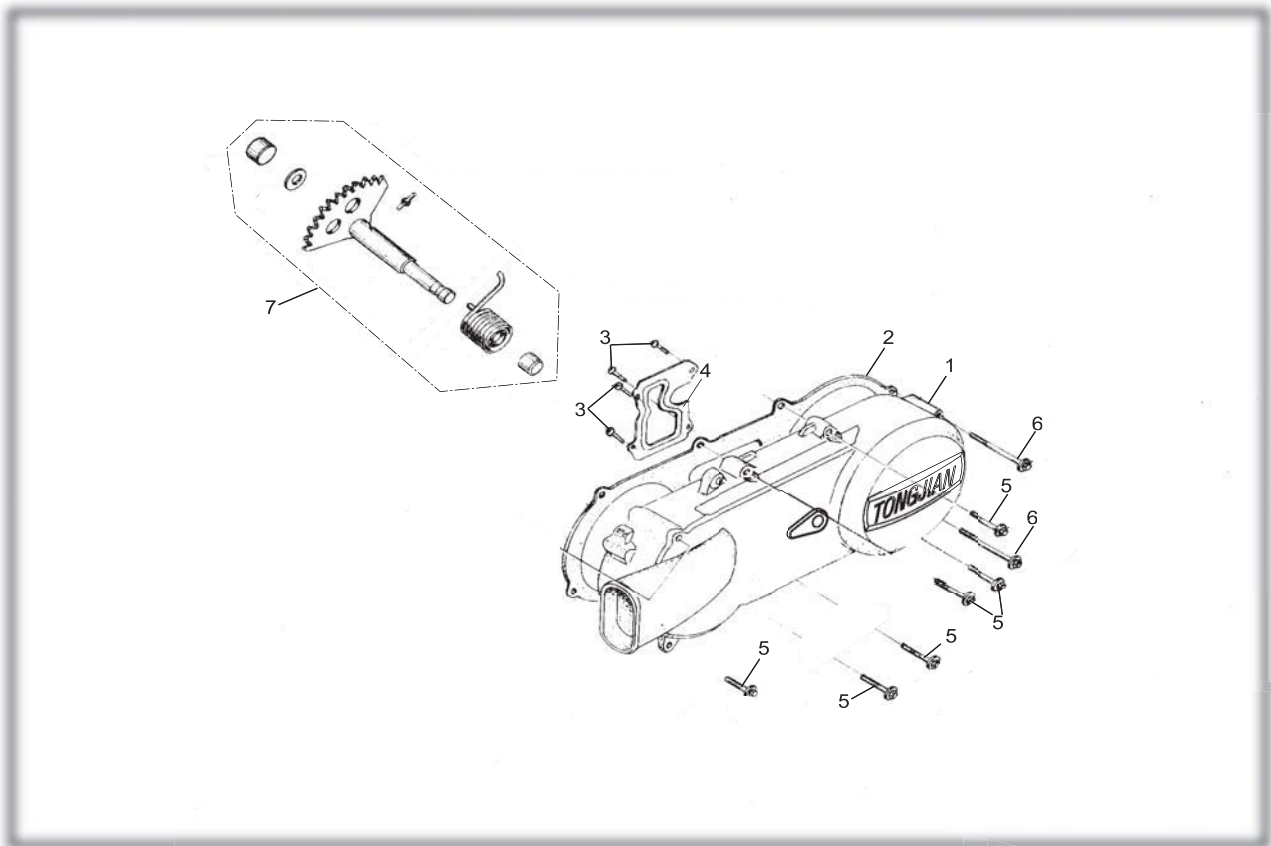

LEFT COVER ASSY.				
REF NO.	PART NO.	DESCRIPTION	REGD NO.	
1	M150-1008101	COVER L	1	
2	M150-1008005	L COVER GASKET	1	
3	93903-00428-KAT	TAPPING SCREW ST4.2X8-F-H	4	
4	M150-1008102	L COVER PLATE	1	
5	M150-1003034	FLANGE BOLT M6X40	6	
6	M150-1008006	FLANGE BOLT M6X65	2	
7	M150-1008200	KICK STARTER ASSY. SPINDLE COMP.	1	

FAN COVER AND SHROUD ASSY.

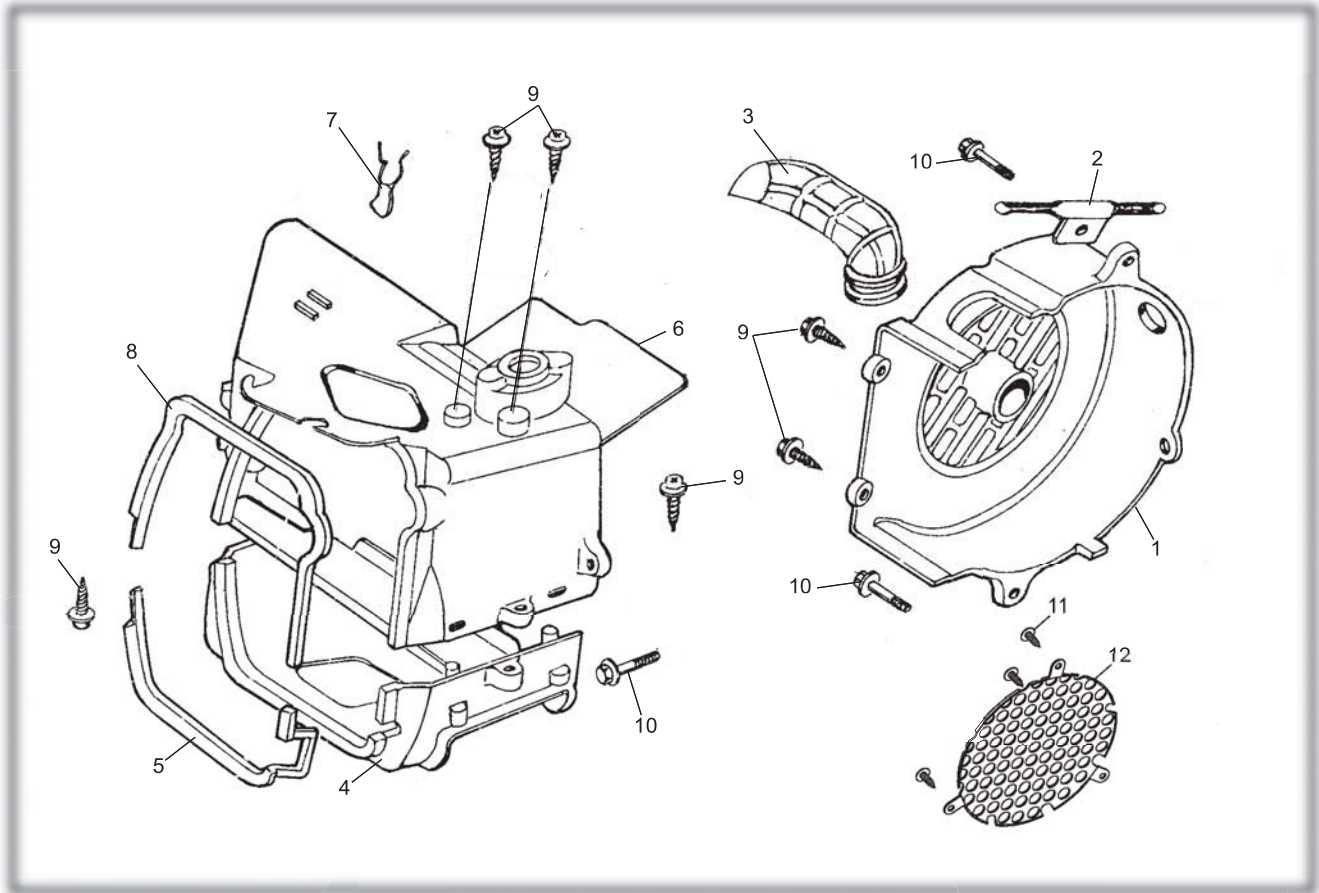

FAN COVER AND SHROUD ASSY.				
REF NO.	PART NO.	DESCRIPTION	REGD NO.	
1	M150-1009410	FAN COVER COMP.	1	
2	M150-1009002	STARTER CABLE CLAMPER	1	
3	M150-1009401	CARBURETOR COOLING DUCT	1	
4	M150-1009301	LOWER SHROUD	1	
5	M150-1009302	LOWER SHROUD SEAL	1	
6	M150-1009110	UPPER SHROUD COMP.	1	
7	M150-1009103	HIGH TENSION CORD CLIP	1	
8	M150-1009102	UPPER SHROUD SEAL	1	
9	M150-1009402	SCREW ST4.8X16-F	6	
10	M150-1003075	BOLT M6X25	3	
11	ST3.5X13 GB845	SCREW ST3.5×13-F	3	
12	8.020.179	DUST COVER	1	

OIL PUMP ASSY.

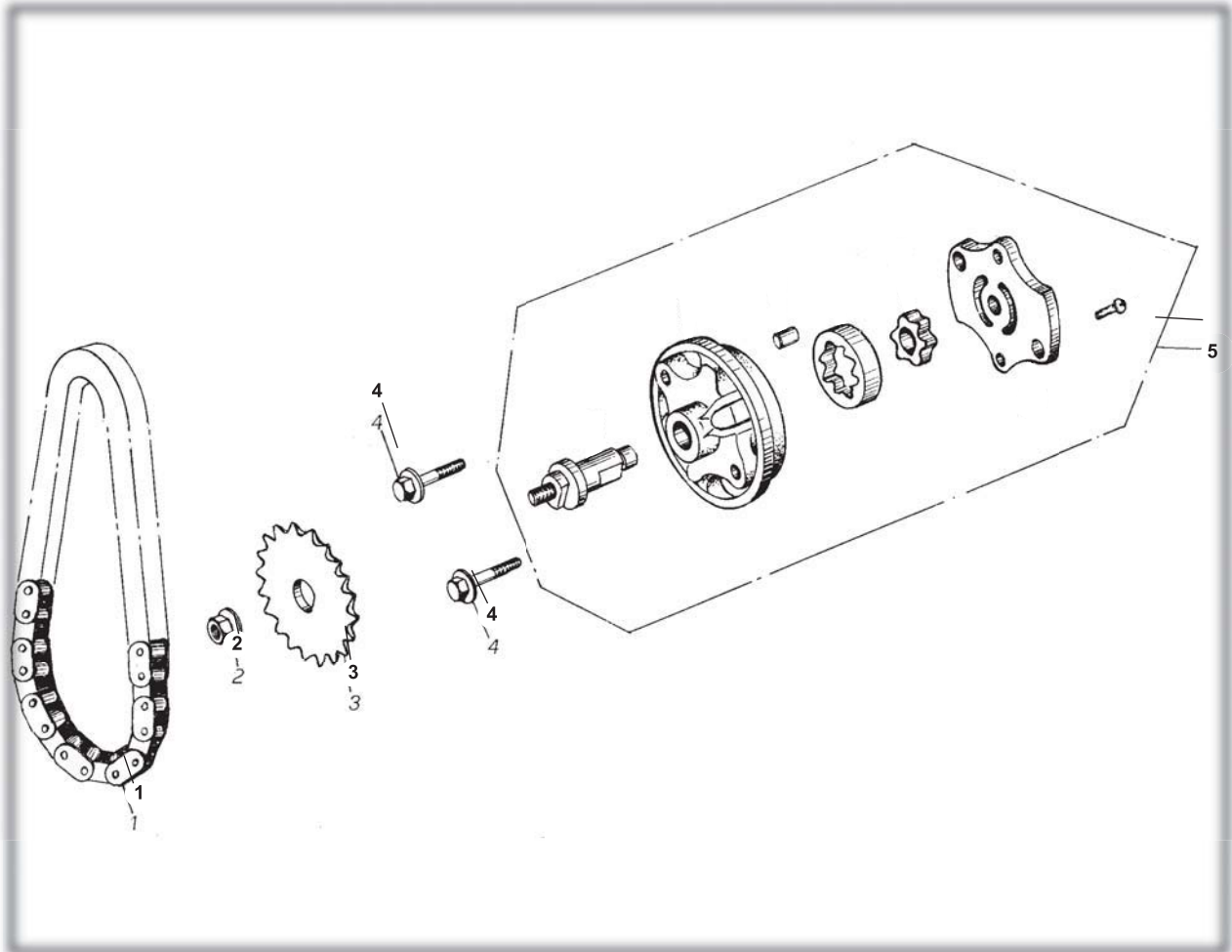

OIL PUMP ASSY.				
REF NO.	PART NO.	DESCRIPTION	REGD NO.	
1	M150-1021000	CHAIN OIL PUMP	1	
2	M150-1020002	NUT FLANGE M6	1	
3	M150-1020001	SPROCKET OIL PUMP DRIVEN	1	
4	M150-B-1003075	BOLT M6X25	2	
5	M150-1022000	OIL PUMP SUB ASSY.	1	

DRIVEN PULLEY AND CLUTCH SUBASSY.

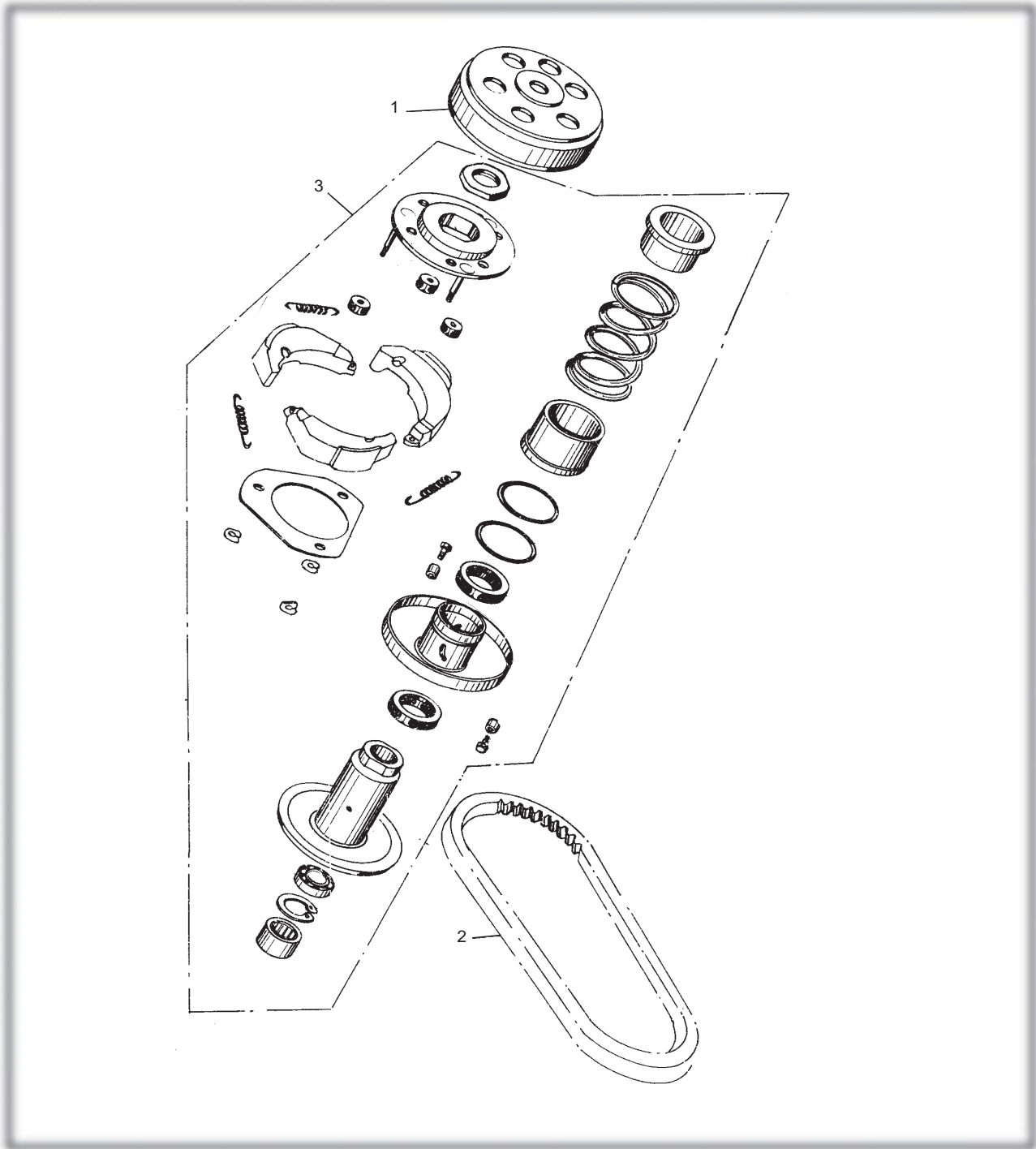

DRIVEN PULLEY AND CLUTCH SUBASSY.

REF NO.	PART NO.	DESCRIPTION	REGD NO.	
1	M150-1032000	CLUTCH ASSY. OUTER	1	
2	M150-1033000	DRIVE BELT	1	
3	M150-1031000	DRIVEN PULLEY ASSY.	1	

TRANSMISSION ASSY.

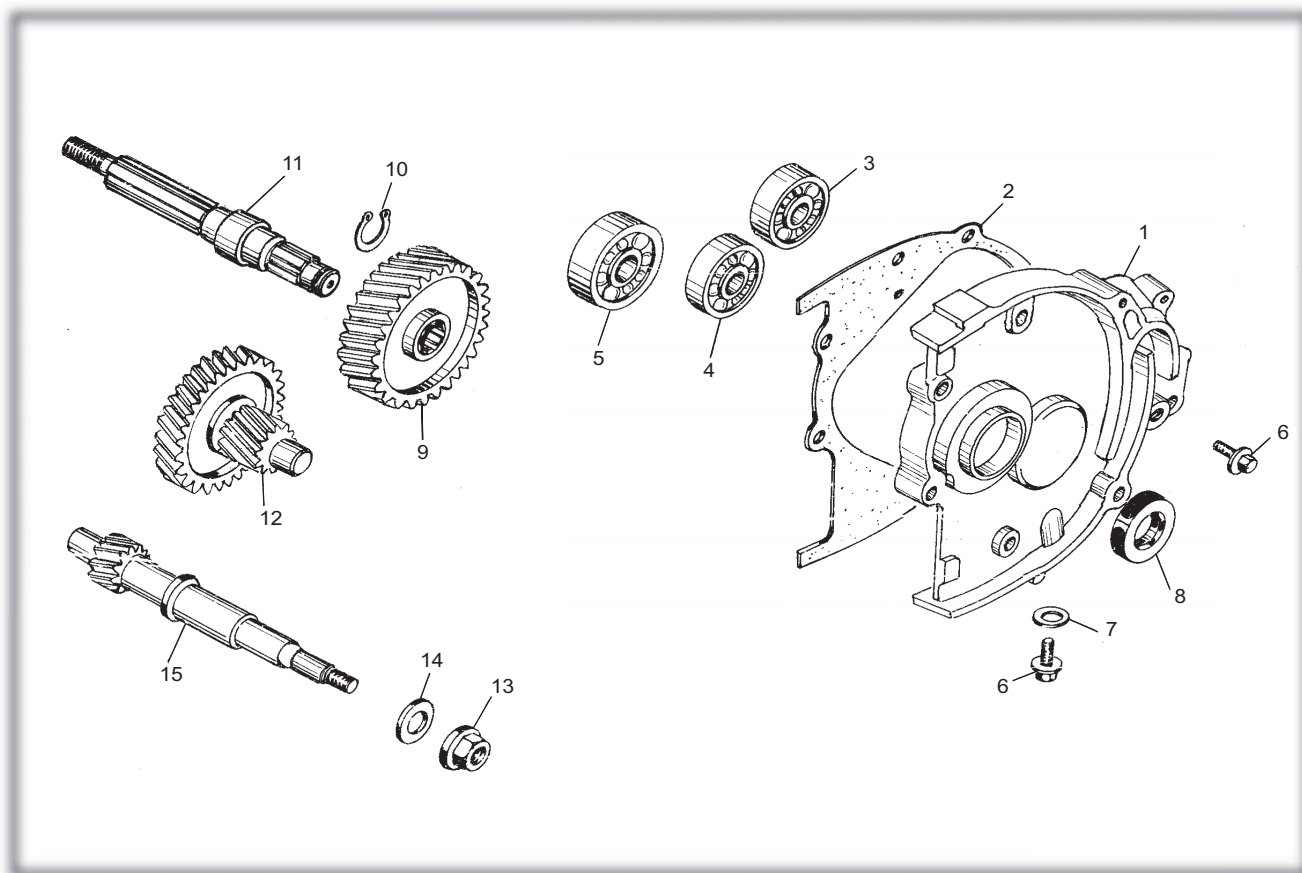

TRANSMISSION ASSY.				
REF NO.	PART NO.	DESCRIPTION	REGD NO.	
1	M150-1040001	TRANSMISSION COVER	1	
2	M150-1041000	TRANSMISSION COVER GASKET	1	
3	91004-E6203-KAT	RADIAL BALL BEARING E6203	1	
4	91004-E6202-KAT	RADIAL BALL BEARING E6202	1	
5	91004-E6204-KAT	RADIAL BALL BEARING E6204	1	
6	M150-1040008	SPECIAL BOLT M8X12	2	
7	M150-1040002	WASHER Φ8	1	
8	M150-1042000	OIL SEAL 20X32X6	1	
9	M150-1040004	FINAL GEAR	1	
10	94510-20000	EXTERNAL CIRCLIP 20	1	
11	M150-1040003	FINAL SHAFT	1	
12	M150-1043000	COUNTER SHAFT COMP.	1	
13	M150-1040007	COMPRESSOR FLANGE NUT M12	1	
14	M150-1040005	WASHER Φ12	1	
15	M150-1040006	DRIVE SHAFT	1	

ELECTRIC SYSTEM

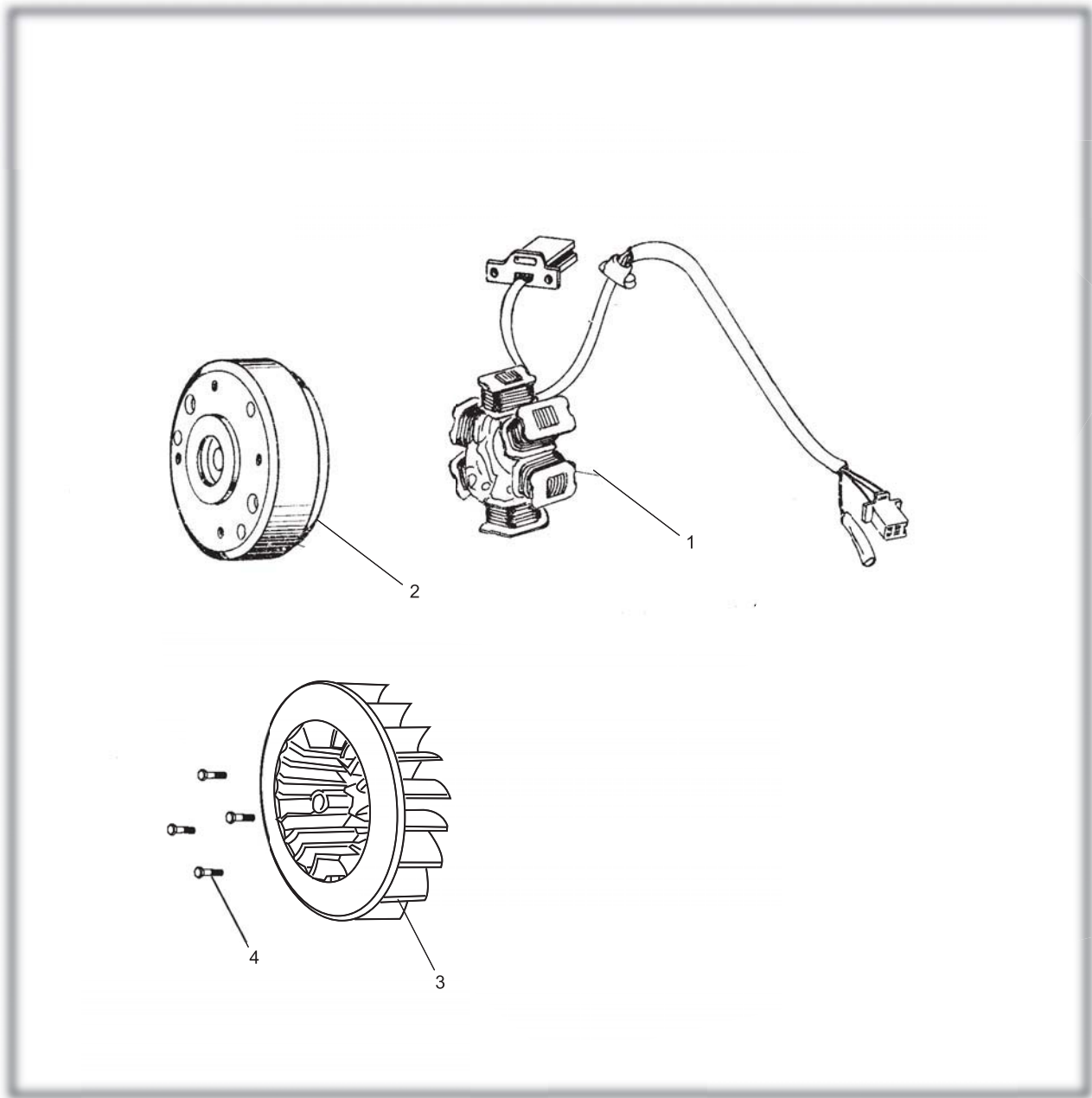

ELECTRIC SYSTEM

REF NO.	PART NO.	DESCRIPTION	REGD NO.	
1	M150-1051200-8	STATOR COMP.	1	
2	M150-1051100	FLYWHEEL COMP.	1	
3	M150-1051100-3	COOLING FAN COMP.	1	
4	M150-1051100-4	FLANGE BOLT M6x18	4	

ELECTRIC STARTER ASSY.

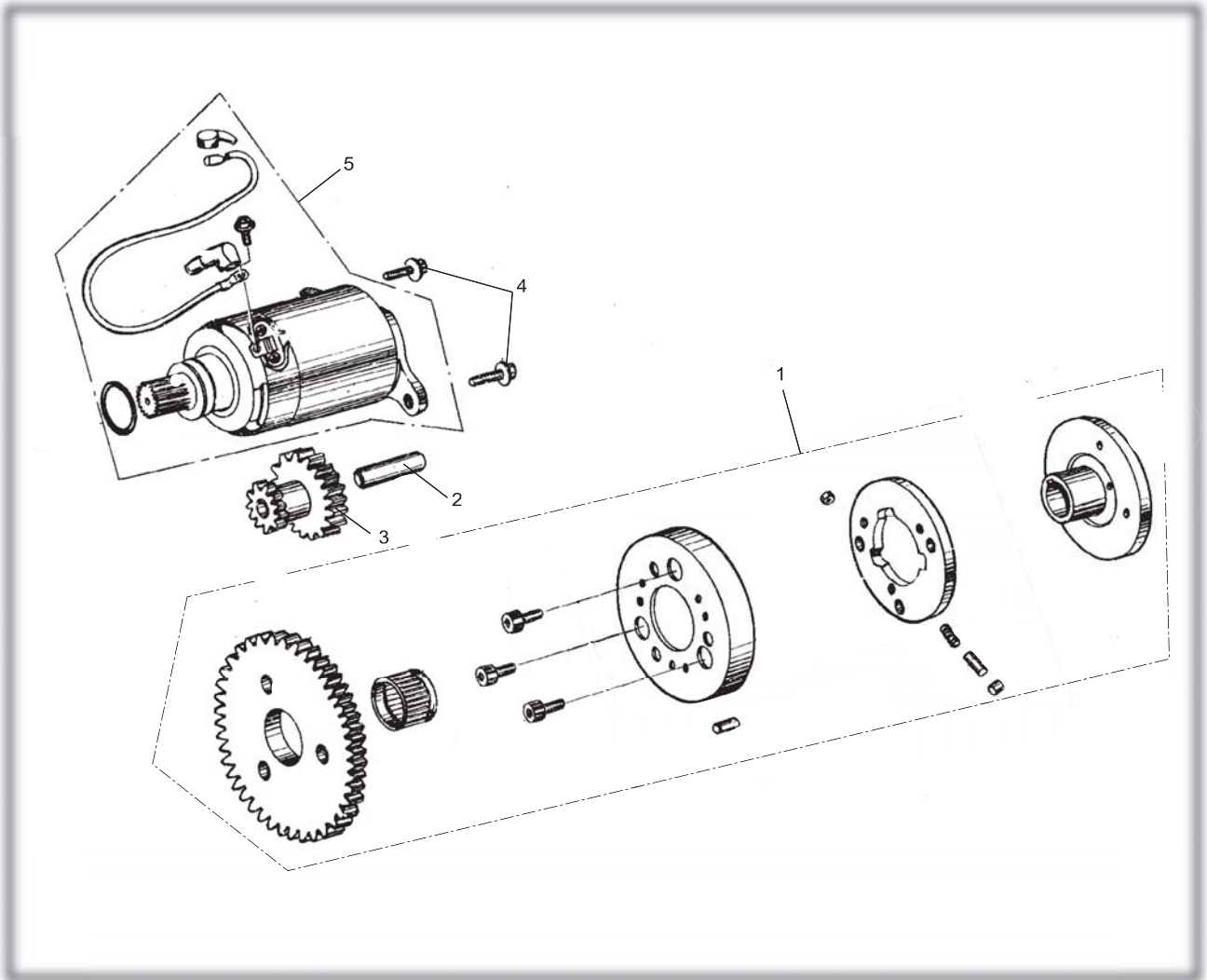

ELECTRIC STARTER ASSY.

REF NO.	PART NO.	DESCRIPTION	REGD NO.	
1	M150-1060001	FLANGE STARTING CLUTCH	1	
2	M150-1060002	STARTER REDUCTION GEAR SHAFT	1	
3	M150-1060003	STARTER REDUCTION GEAR	1	
4	M150-1060005	FLANGE BOLT M6X16	2	
5	M150-1064000	STARTER MOTOR ASSY.	1	

DRIVE PULLEY SUBASSY.

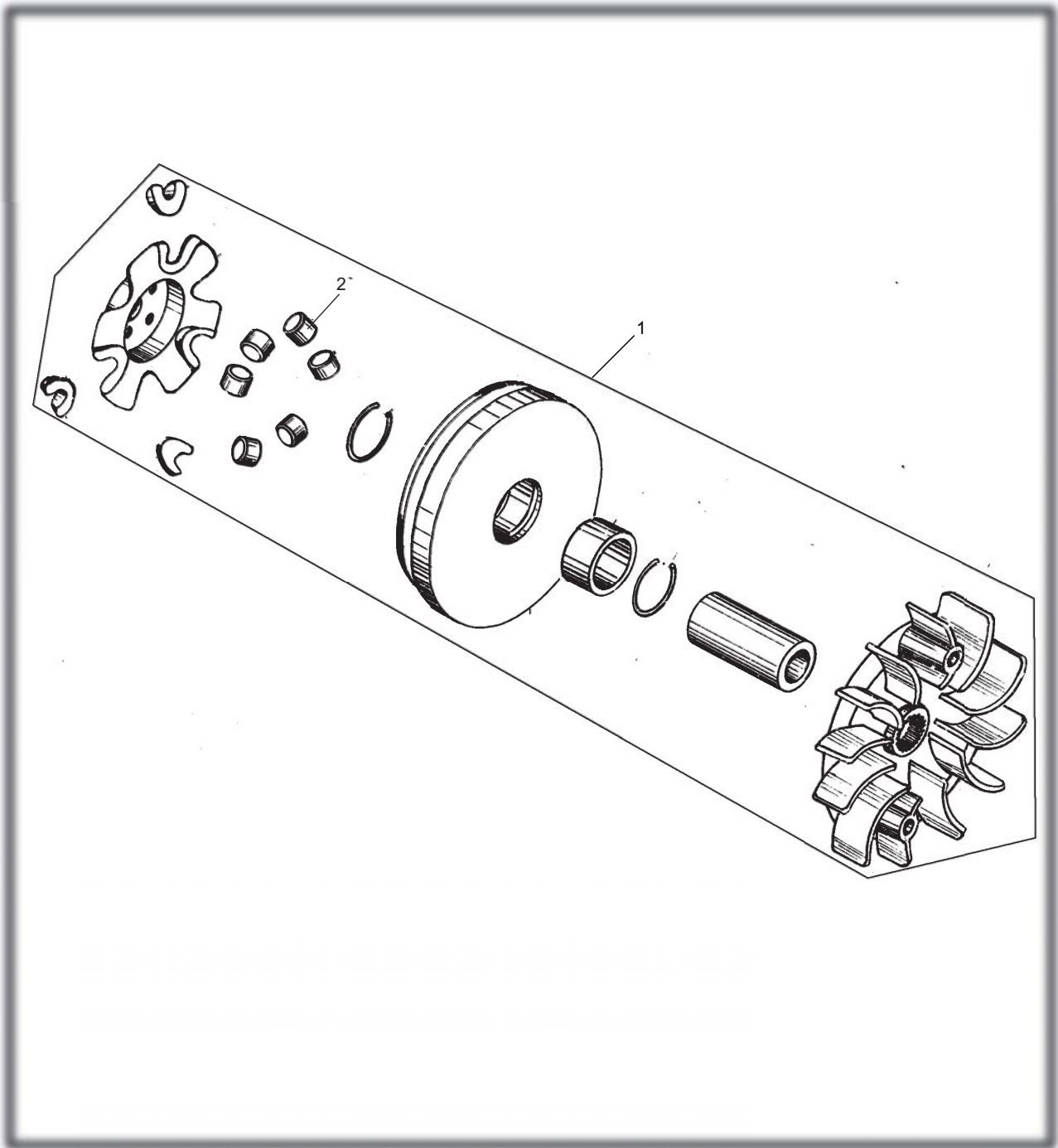

DRIVE PULLEY SUBASSY.

REF NO.	PART NO.	DESCRIPTION	REGD NO.	
1	M150-1071000	MOVABLE DRIVE PULLEY ASSY.	1	
2	M150-10710002	ROYER	6	

Plastic Body Parts

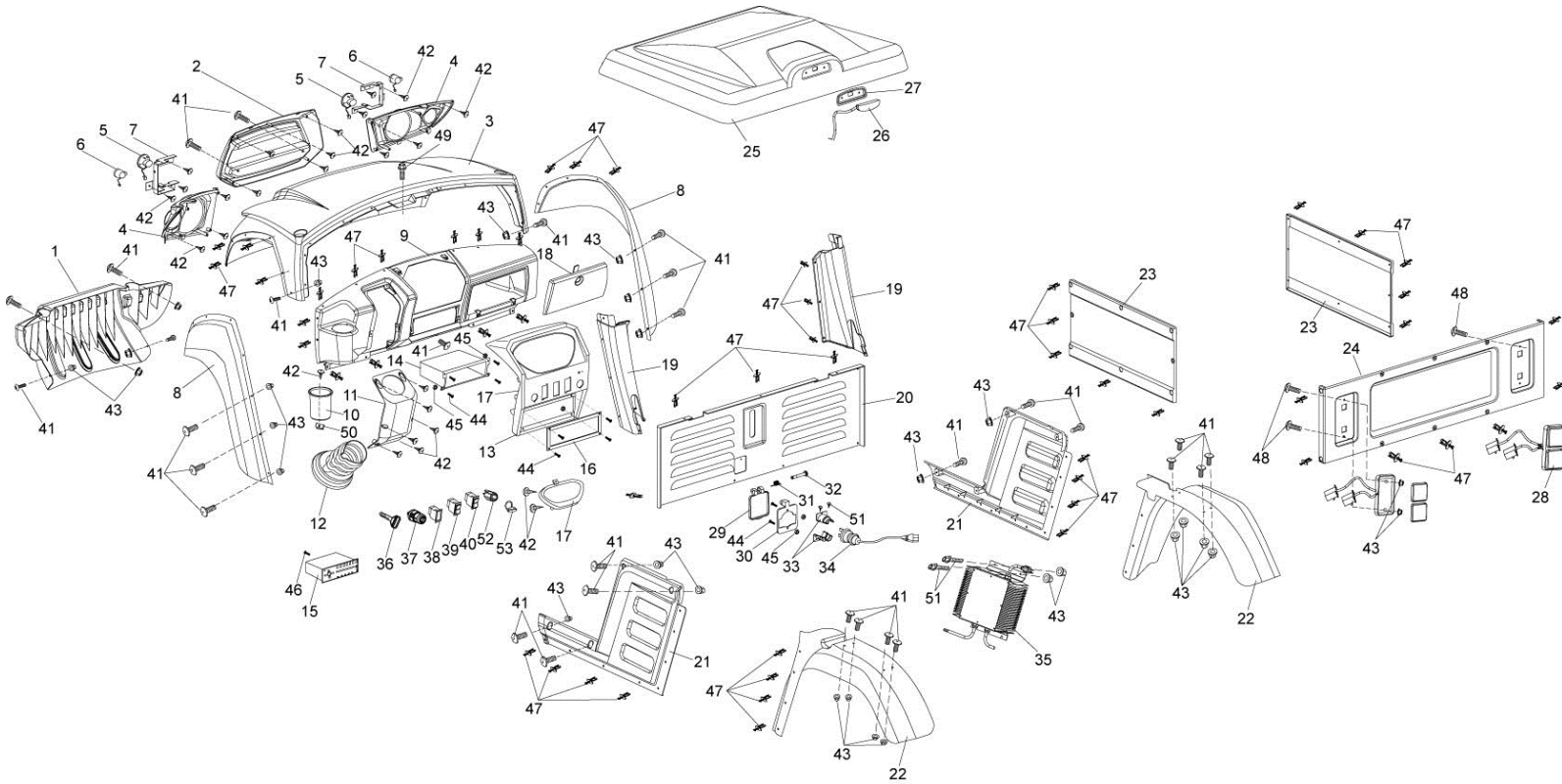

REF#	HH PART#	DESCRIPTION	PCS
F1-1	15-0208-00	FRONT BUMPER	1
F1-2	15-0203-00	FRONT HOOD INSERT	1
F1-3	15-0201-00	HOOD UPPER	1
F1-4	15-0209-00L	HEADLIGHT COVER, LH	1
	15-0209-00R	HEADLIGHT COVER, RH	1
F1-5	15-0206-00	HEADLIGHT	2
F1-6	15-0210-00	FRONT BLINKER	1
F1-7	15-0607-00	HEADLIGHT BRACKET	2
F1-8	15-0211-00L	FR. FENDER, LH	1
	15-0211-00R	FR. FENDER, RH	1
F1-9	15-0214-00	DASHBOARD	1
F1-10	15-0212-00	CUP HOLDER	1
F1-11	18-0213-00	PROTECTIVE PANEL, STEERING SHAFT	1
F1-12	15-0504-00	BOOT, STEERING SHAFT	1
F1-13	15-0205-00	CENTER CONSOLE	1
F1-14	15-0215-00	CD PLAYER SLOT	1
F1-15			1
F1-16	15-0216-00	CD PLAYER SLOT, BORDER	1
F1-17	18-0305-00	SPEEDOMETOR	1
F1-18	15-0217-00	CLOVE COMPARTMENT COVER	1
F1-19	15-0218-00	LOWER PROTECTIVE PANEL, FR. (PAIR)	1
F1-20	18-0219-00	SEAT TUB FRONT PANEL	1
F1-21	15-0220-00L	SEAT TUB SIDE PANEL, LEFT	1
	15-0220-00R	SEAT TUB SIDE PANEL, RIGHT	1
F1-22	15-0221-00L	TIRE WELL, REAR LEFT	1
	15-0221-00R	TIRE WELL, REAR RIGHT	1
F1-23	15-0222-00	DUMP BED SIDE PANEL	2

REF#	HH PART#	DESCRIPTION	PCS
F1-24	15-0223-00	DUMP BED BACK PANEL	1
F1-25	15-0224-00	ROOF	1
F1-26	15-0205-00	ROOF BRAKE LIGHT	1
F1-27	15-0506-00	ROOF BRAKE LIGHT RUBBER SEAL	1
F1-28	15-0226-00	REAR TAIL LIGHT	2
F1-29	15-0227-00	CHARGER FLIP COVER (NEED ASSEMBLY)	1
F1-34	15-0701-00	EXTENSIVE CABLE, CHARGER	1
F1-35	15-0306-00	CHARGER	1
		KEY SWITCH, (KEY AND SWITCH A SET)	1
F1-37	15-0301-00	KEY SET	1
F1-38	15-0307-00	BATTERY METER	1
F1-39	15-0308-00	FORWARD/REVERSE SWITCH	1
F1-40	15-0309-00	HAZARD LIGHT SWITCH	1
F1-41	003-060015-00	SCREW CROSS, M6X15	31
F1-42	003-480015-02	SCREW CROSS, ST4.8X15	33
F1-43	9.220.006	SELF-LOCK NUT M6	34
F1-44	003-040010-00	SCREW CROSS, M4X10	10
F1-45	9.220.004	NUT, M4	10
F1-46	003-040025-00	SCREW CROSS, M4X25	1
F1-47	003-000000-03	SCREW, ANCHOR	78
F1-48	003-060010-00	SCREW CROSS, M6X10	4
F1-49	9.108.016	FLANGE BOLT, M8X1.25X15	1
F1-50	15-1809-00	LATCH	1
F1-51	9.106.035	FLANGE BOLT, M6X35	2
F1-52	15-0310-00	12 V POWER OUTLET	1
		COVER, 12V POWER OUTLET	1

Overhead Brush Guards

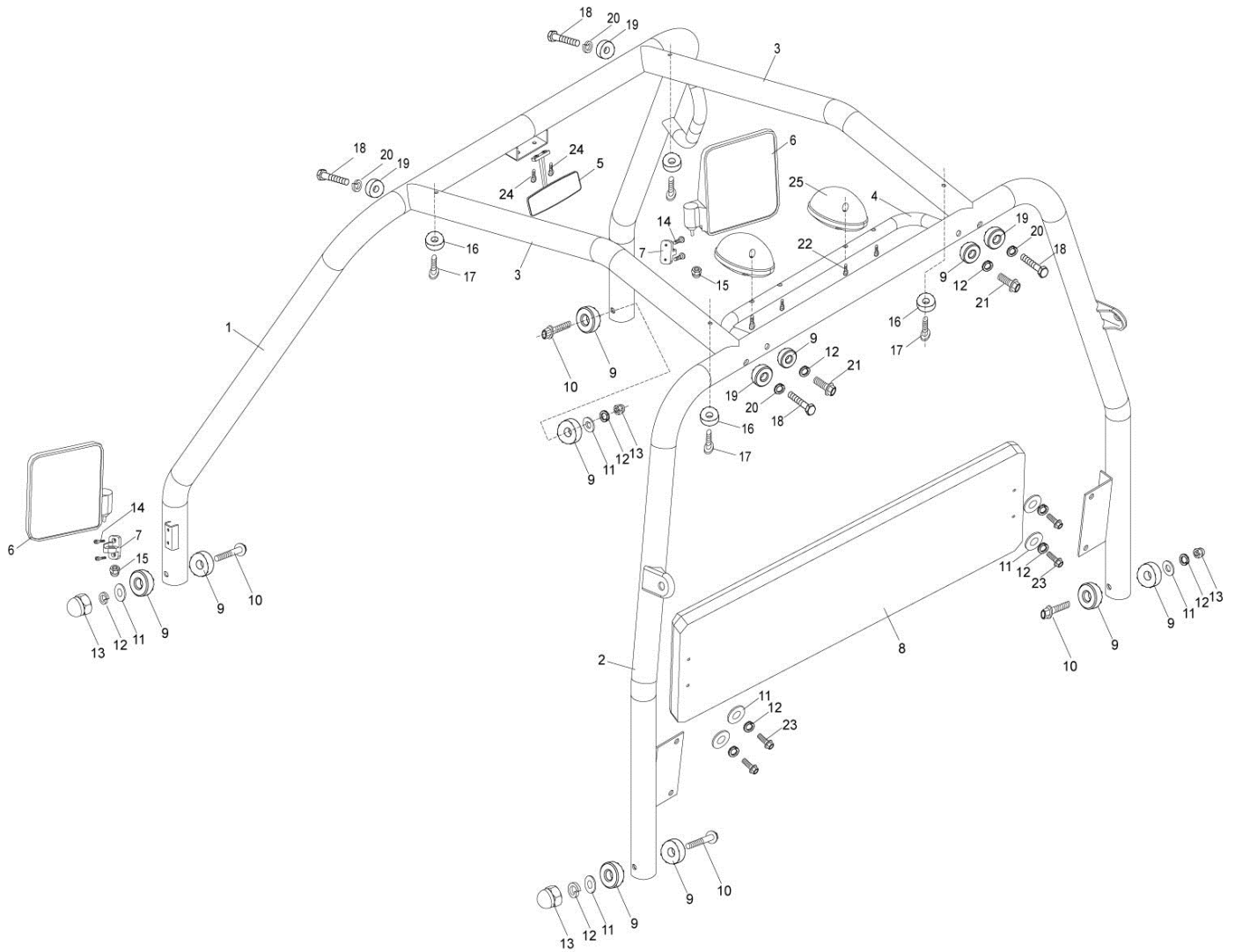

REF#	HH PART#	DESCRIPTION	PCS
F2-1	15-0101-00	FRONT BRUSH GUARD (LEFT TO RIGHT)	1
F2-2	15-0104-00	REAR BRUSH GUARD (LEFT TO RIGHT)	1
F2-3	15-0102-00	TOP BRUSH GUARD	2
F2-4	15-0105-00	SPEAKER MOUNTING BAR	1
F2-5	6.000.084	INNER MIRROR	1
F2-6	15-1801-00	RR. VIEW MIRROR (PAIR)	1
F2-7	15-1804-00	FIXING BASE, RR. VIEW MIRROR (PAIR)	1
F2-8	15-0402-00	BACK, SEAT	1
F2-9	007-8P5-00	WASHER, SPHERICAL Ø8.5	10
F2-10	9.108.060	FLANGE BOLT, M8X1.25X60	4
F2-11	9.300.008	WASHER, Ø8	8
F2-12	9.400.008	SPRING WASHER, Ø8	10

REF#	HH PART#	DESCRIPTION	PCS
F2-14	9.220.016	HEXAGON BOLT, M6X20	4
F2-15	009-060000-00	ACORN NUT, M6	2
F2-16	007-7-00	WASHER, SPHERICAL Ø7	4
F2-17	9.600.655	SCREW CROSS, M6X55	4
F2-18	9.110.055	HEX BOLT, M10X1.25X55	4
F2-19	007-10P5-00	WASHER, SPHERICAL Ø10.5	4
F2-20	9.400.010	SPRING WASHER, Ø10	4
F2-21	9.108.060	FLANGE BOLT, M8X1.25X60	2
F2-22	9.600.700	SCREW CROSS, M6X70	4
F2-23	9.108.030	FLANGE BOLT, M8X1.25X30	4
F2-24	003-050015-00	SCREW CROSS, M5X15	2
F2-25	15-1802-00	SPEAKERS	2

Main Frame

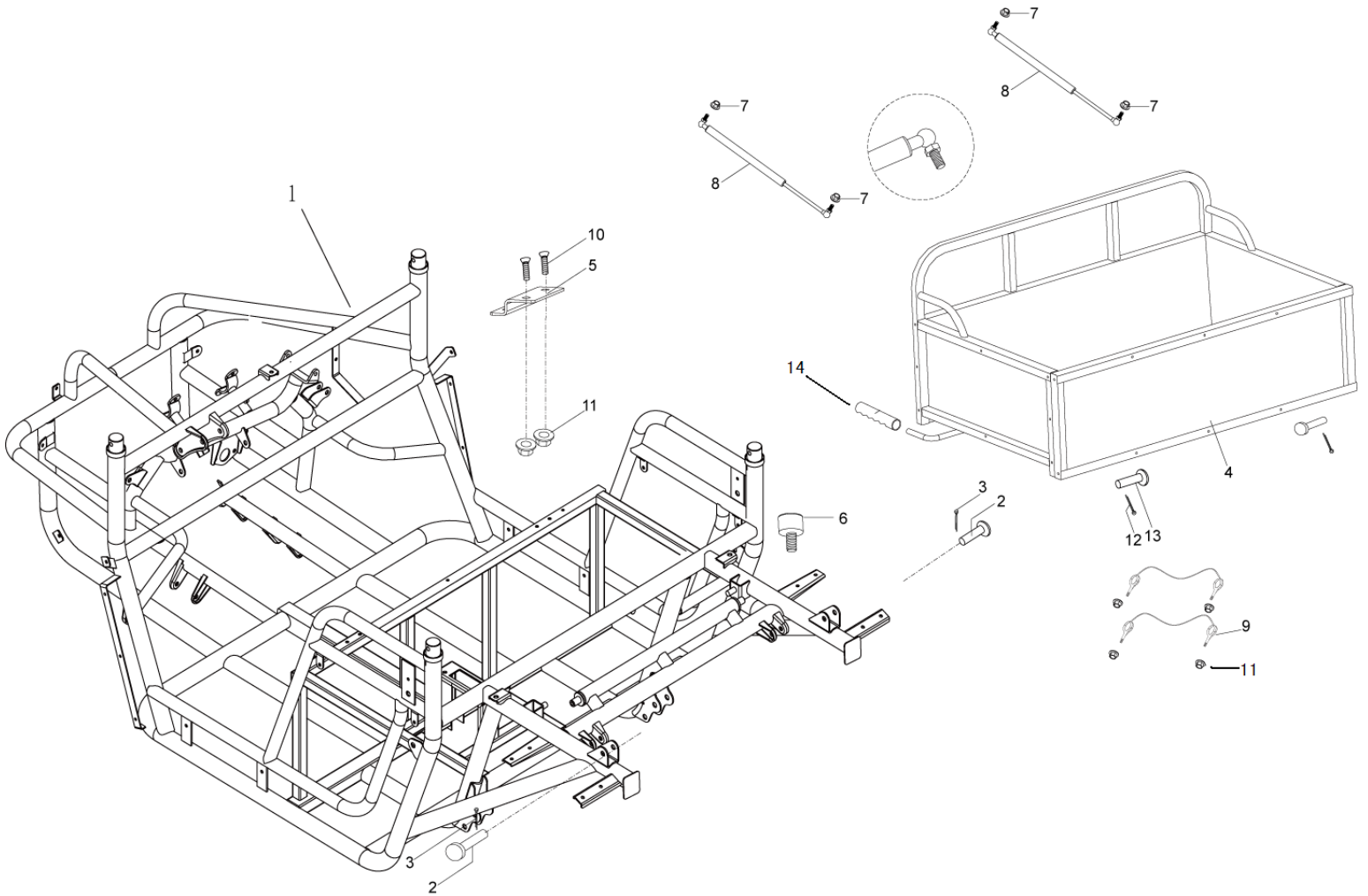

REF#	HH PART#	DESCRIPTION	PCS
F3-1	18-0608-00	VEHICLE FRAME	1
F3-2	020-12X50-00	SHAFT PIN, Ø12X50	2
F3-3	9.500.325	COTTER PIN	2
F3-4	18-0609-00	DUMP BED	1
F3-5	15-0501-00	RUBBER HANDLE GRIP, DUMP BED	2
F3-6	15-0507-00	RUBBER COLLAR, DUMP BED	2
F3-7	9.220.008	SELF-LOCK NUT M8X1.25	4
F3-8	15-1803-00	ACTUATOR	2
F3-9	15-1807-00	ROD, BATTERY HOLDER	3

REF#	HH PART#	DESCRIPTION	PCS
F3-10	15-0231-00	FIXING PLATE, BATTERY HOLDE	3
F3-11	9.300.008	WASHER, Ø8	3
F3-12	9.220.006	SELF-LOCK NUT M6	8
F3-13	9.600.016	BOLT, CROSSING M6X15	1
F3-14	9.500.225	COTTER PIN	2
F3-15	15-0622-00	SHAFT PIN, DUMP BED	2
F3-16		LOWER HINGE, FR. SEAT	2
F3-17	013-060040-00	COUNTERSUNK BOLT, CROSSIN	4

Steering System

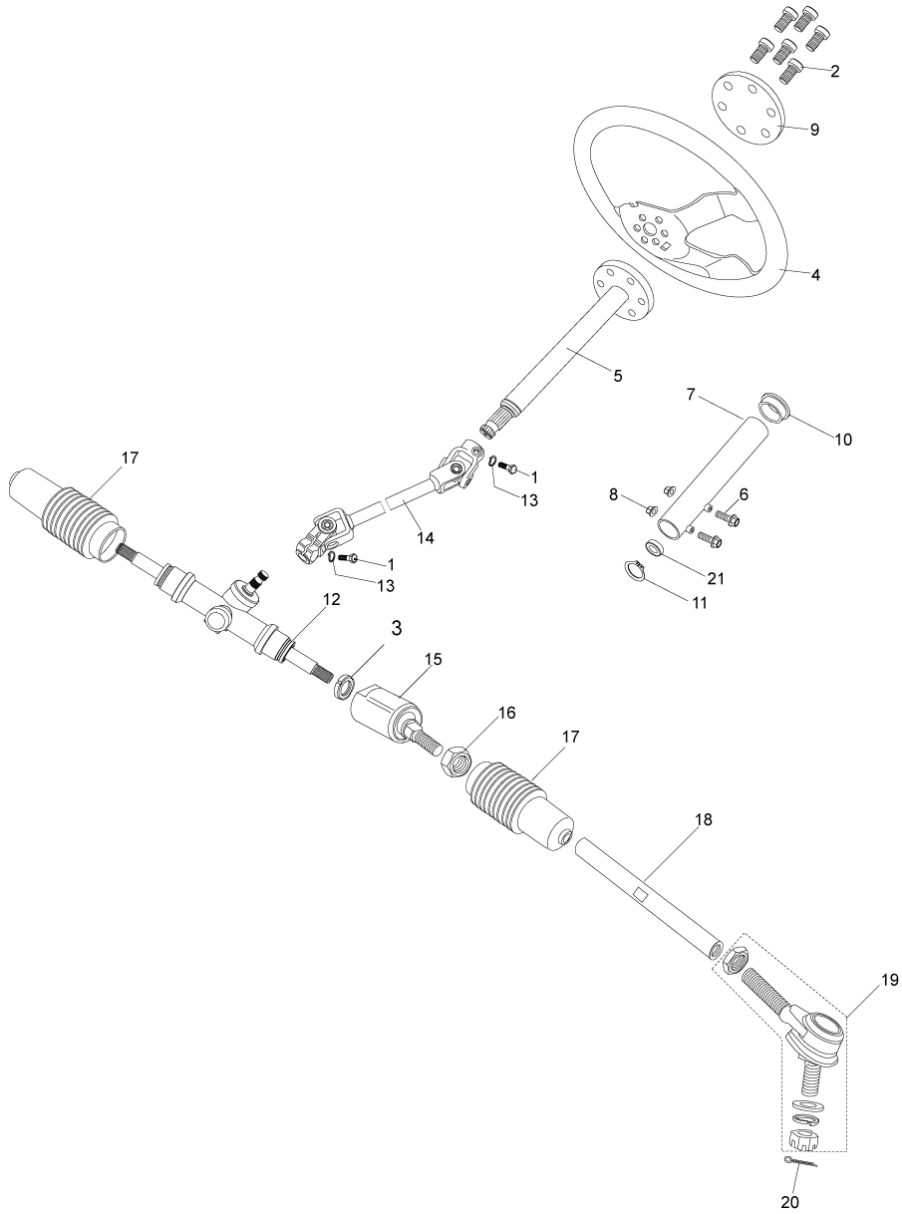

REF#	HH PART#	DESCRIPTION	PCS
1	9.108.025	BOLT, M8X30	2
2	9.106.016	BOLT, M6X15	6
3	9.900.016	ROUND NUT	2
4	15-1003-00	STEERING WHEEL	1
5	15-1004-00	STEERING COLUMN	1
6	9.110.075	FLANGE BOLT, M10X1.25X75	2
7	18-1005-00	STEERING POST	1
8	9.220.010	SELF-LOCK NUT, M10X1.25	2
9	15-0213-00	COVER, STEERING WHEEL	1
10	15-1011-00	STEERING AXLE CAP	1
11	016-190000-00	C-Clip Radius 19	1
12	18-1006-00	RACK AND PINION ASSY.	1

REF#	HH PART#	DESCRIPTION	PCS
13	9.400.008	SPRING WASHER Ø8	2
14	18-1007-00	STEERING UNIVERSAL JOINT	1
15	15-1008-00	TIE ROD END	2
16	9.220.012	NUT, M12X1.25	2
17	15-0504-00	BOOT	2
18	18-1009-00	TIE ROD	2
19	15-1010-00	BALL JOINT ASSY.	2
20	9.500.235	COTTER PIN 2.5X35	2
21	010-61904	BEARING 61904	1
22	9.900.016	ROUND NUT	2
			2
			1

Front Suspension

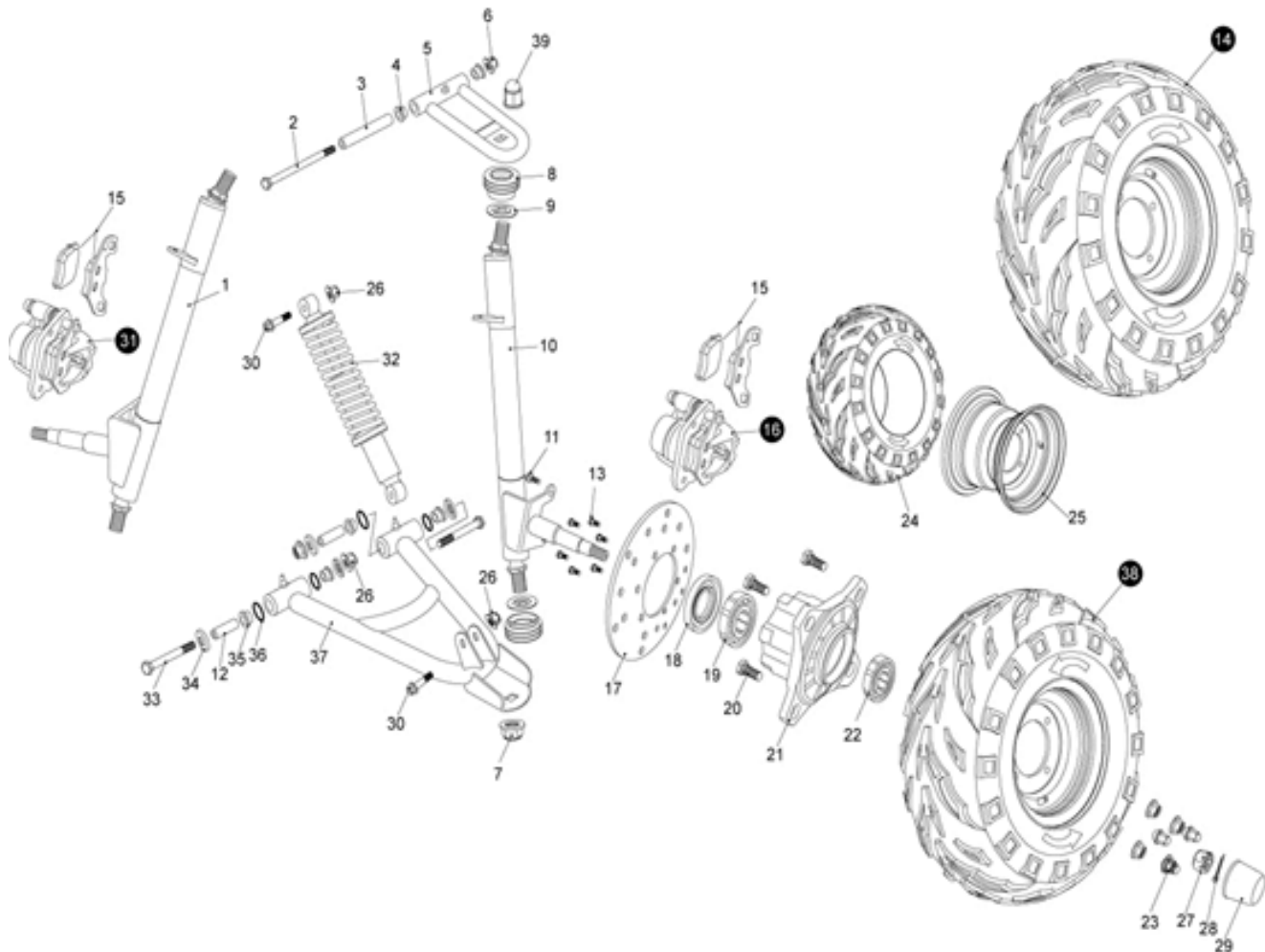

REF#	HH PART#	DESCRIPTION	PCS	REF#	HH PART#	DESCRIPTION	PCS
1	2.000.028	STRUT AND SPINDLE SUPPORT, R	1	21	8.010.085B	FRONT WHEEL HUB	2
2	9.108.105	FLANGE BOLT M8x1.25x105	2	22	9.030.010	BEARING 6202-Z	2
3	8.010.015	UPPER SUSPENSION ARM COLLAR	2	23	9.220.010	LOCKING FLANGE NUT M10	8
4	7.010.003	UPPER SUSPENSION ARM BUSHING	4	24	14813	FRONT TIRE 20x8-8	1
5	4.000.004	UPPER SUSPENSION ARM	2	25	002-10080-B	FRONT WHEEL 8" STEEL BLACK	2
6	9.220.008	LOCKING FLANGE NUT. M8	2	26	9.220.010	LOCKING FLANGE NUT M10	16
7	7.010.140	LOCKING FLANGE NUT. M12	4	27	9.800.012	CASTLE NUT M12	2
8	7.020.025	BALL HEAD DUST SEAL	4	28	9.500.220	COTTER PIN Φ 2x20	2
9	8.020.053	BALL HEAD SPACER	4	29	7.020.039	FR. HUB COVER.	2
10	2.000.027	STRUT AND SPINDLE SUPPORT, L	1	30	9.110.040	FLANGE BOLT M10x1.25x40	4
11	9.908.014	BOLT STRAP M8x14	4	31	6.000.095	FRONT BRAKE CALIPER. R	1
12	8.010.014	LOWER SUSPENSION ARM COLLAR	4	32	6.000.325	CUSHION ASSY. FR L=325	2
13	9.906.012	BOLT STRAP M6x12	12	33	9.110.080	FLANGE BOLT M10x1.25x80	4
14	18-0903-00	FRONT TIRE & WHEEL, RIGHT 20x8-8	1	34	8.020.034	LOWER SUSPENSION ARM DUST CAP	8
15	7.020.016	PAD SET. FR. BRAKE CALIPER	2	35	7.010.002	LOWER SUSPENSION ARM BUSHING	8
16	6.000.028	FRONT BRAKE CALIPER. L	1	36	9.040.001	O-RING Φ 21.2x2.65	8
17	8.010.054	FRONT DISC BRAKE	2	37	4.000.023	LOWER SUSPENSION ARM ASSY.	2
18	9.040.002	DUST SEAL 47x25-7	2	38	18-0901-00	FRONT TIRE & WHEEL, LEFT 20x8-8	1
19	9.030.002	BEARING 6204-Z	2	39	8.010.140	ACORN NUT M12	2
20	9.710.031	TIRE BOLT M10x1.25x31	8				

Seat, Brake, Pedals

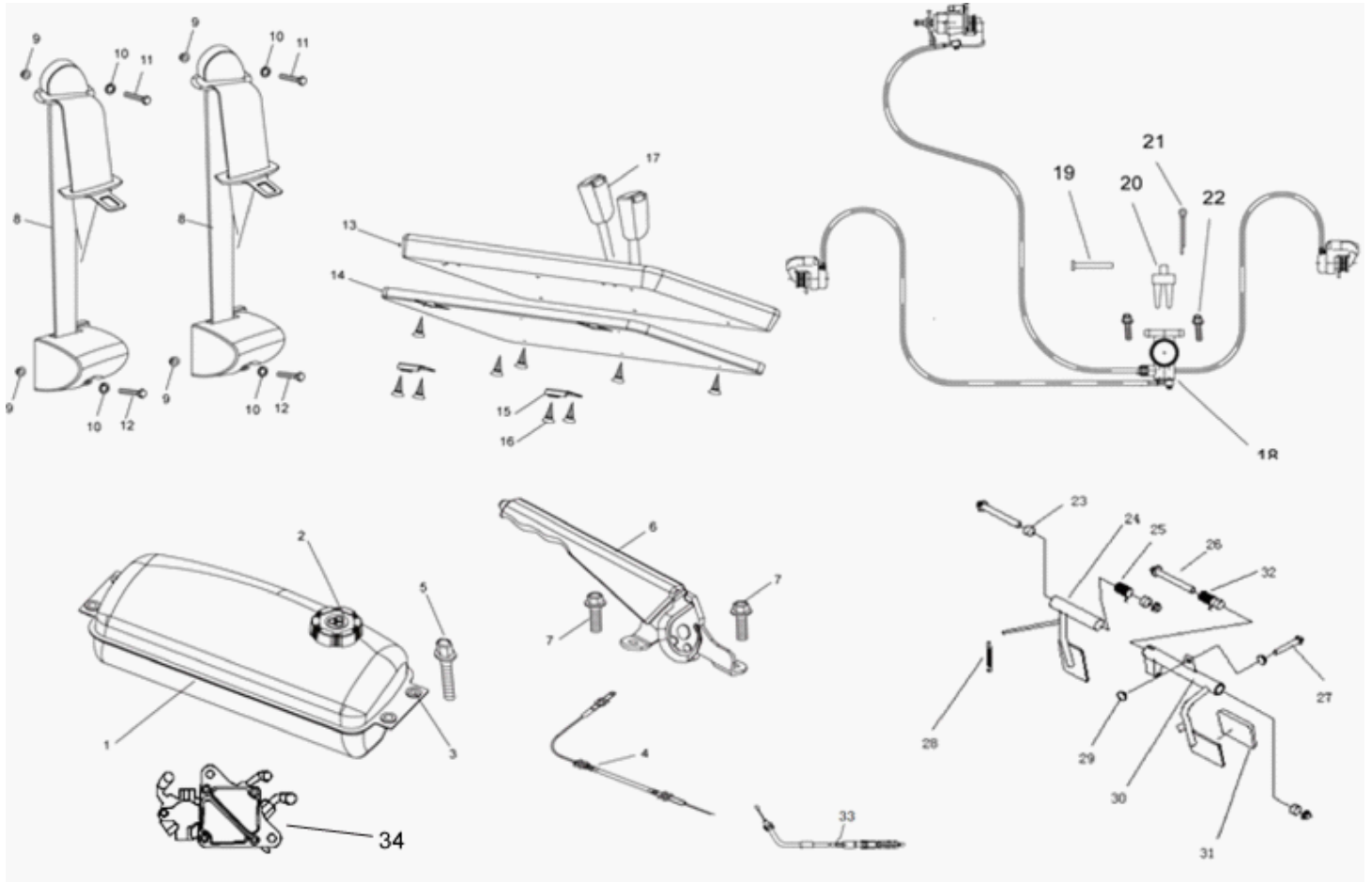

REF#	HH PART#	DESCRIPTION	PCS
1	4.000.011	Fuel Tank	1
2	6.000.053	Fuel Cap	1
3	7.020.005	Rubber Mount	4
4	18-0707-00	Parking Brake Cable	1
5	9.908.055N	Bolt, M8 X 1.25 X 55	4
6	15-1412-00	Lever, Hand Brake	1
7	9.108.020	Flange Bolt	2
8	15-0403-00	Seat Belt	2
9	9.220.010	Nut, M10	4
10	9.400.010	Spring Washer	4
11	9.110.020	Bolt, M10X1.25X20	2
12	9.110.025	Bolt, M10X1.25X25	2
13	15-0401-00	Seat Cushion	1
14	15-0229-00	Seat Tub Cover	1
15	15-0408-00	Upper Hinge, Front Seat	2
16	014-480015-00	Counter Sunk Screw	12
17	15-0406-00	Front Right Seat Belt Buckle	2

REF#	HH PART#	DESCRIPTION	PCS
18	18-1400-00	Complete brake System	1
19		Cotter Pin 6X25	1
20	8.030.024	Spindle Bracket	1
21	9.500.430	Cotter Pin 4 x 30	1
22	9.108.035	Bolt Washer M8x1.25x35	2
23	14119	Bushing Sleeve 12 X 21 X 12	4
24	18-0610-00	Throttle Pedal	1
25	14113	Spring, Throttle Pedal	1
26	9.100.845	Bolt, M8 X 1.25 X 145 HHCS ZN	2
27	9.100.840	Bolt M8X1.25X40	1
28	14852	Spring, Throttle Pedal	1
29	14088	M8X1.25 Nut	4
30	18-1413-00	Brake Pedal	1
31	2-70261	Brake Pedal Rubber	2
32		Spring	1
33	18-0704-00	Throttle Cable	1
34	18-0321-00	Fuel Pump	1

Electric Components

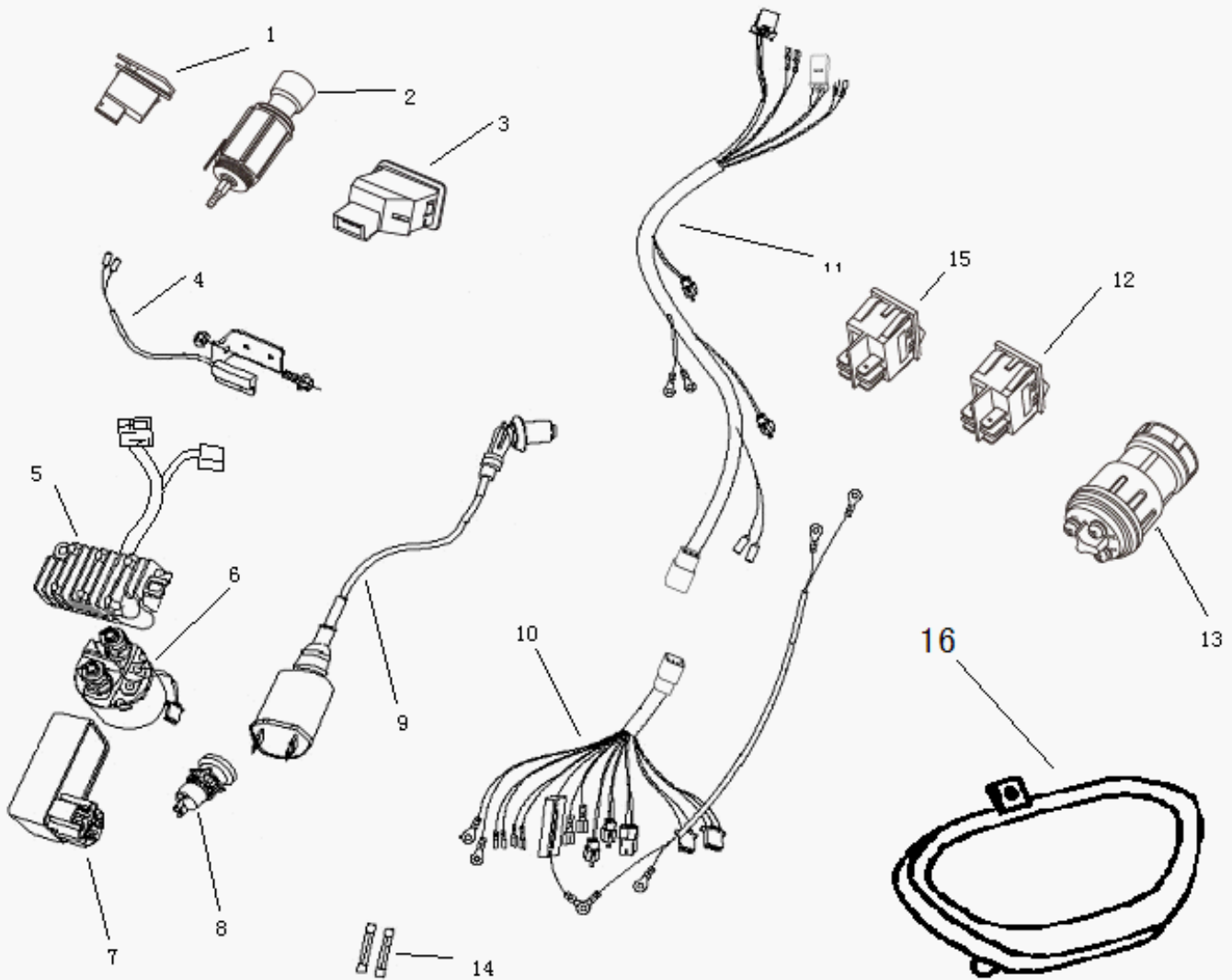

REF#	HH PART#	DESCRIPTION	PCS
1	6.000.079	Horn Switch	1
2	6.000.087	12Volt Outlet	1
3	6.000.113	Blinker Switch	1
4	12.026.023	Speedometer Sensor	1
5	6.000.124	Regulate Rectifier Comp.	1
6	6.000.035	Starter Relay	1
7	6.000.267	C.D.I.	1
9	6.000.025	Ignition Coil	1
10	18-0316-00	Swing Arm Wire Harness	1
11	18-0303-00	Main Wire Harness	1
12	6.000.160	Headlight Switch	1
13	6.000.158	Ignition key Switch	1
15	15-0309-00	Hazard Switch	1
16	18-0300-00	Speedometer	1

Lower Swing Arm

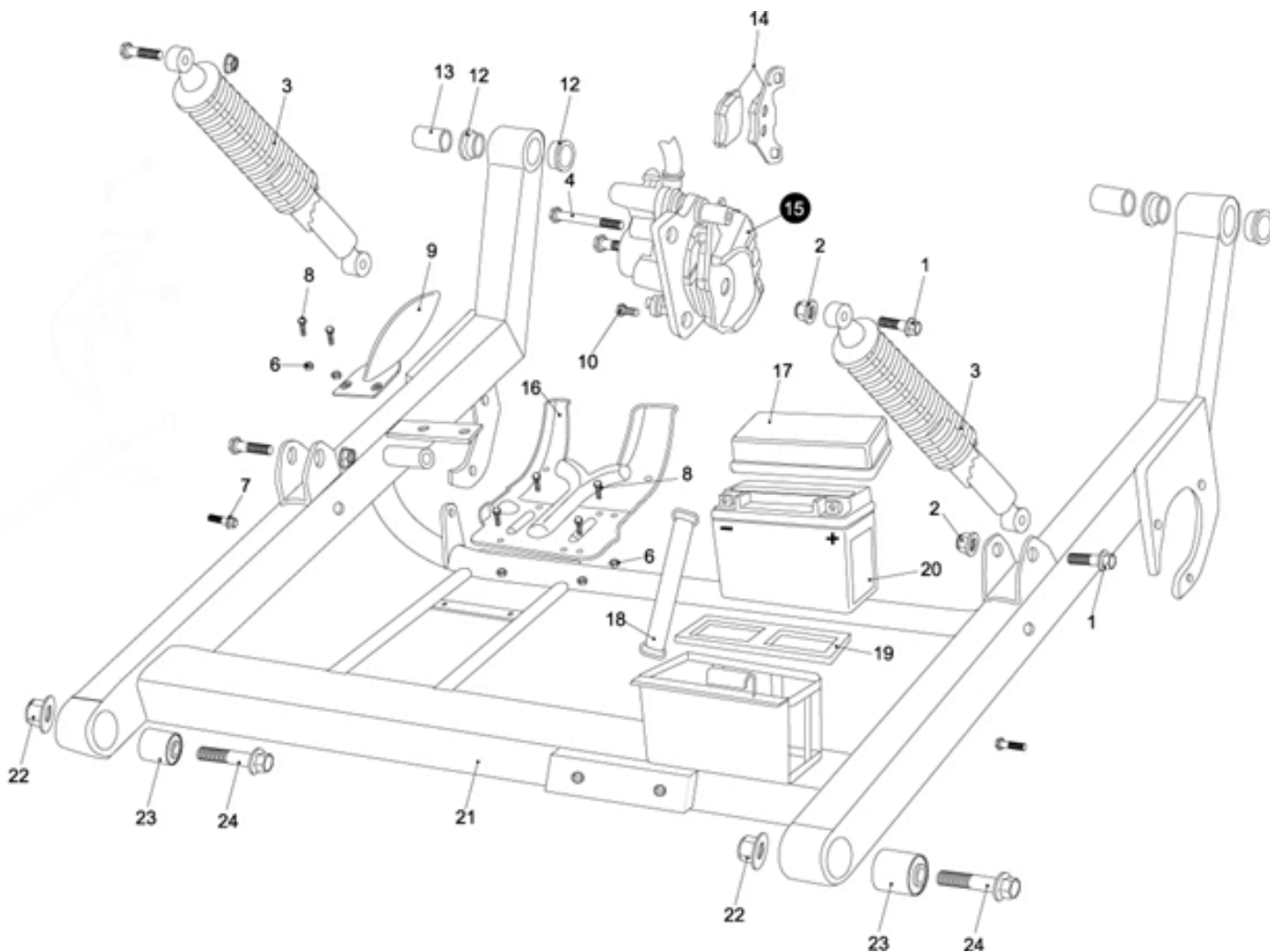

REF#	HH PART#	DESCRIPTION	PCS
1	9.110.040	FLANGE BOLT M10x1.25x40	4
2	9.220.010	LOCKING FLANGE NUT M10	4
3	6.000.006	CUSHION ASSY. RR	2
4	9.908.100	BOLT STRAP M8x1.25x100	1
7	9.108.045	FLANGE BOLT M8x1.25x45	2
9	7.010.031	DISC. RR COVER	1
10	9.908.012	BOLT STRAP M8x1.25x12	1
11	13-0601-00R	REAR FENDER BRACKET, R	1
12	7.010.006	SWING ARM BUSHING	4
13	8.010.028	SWING ARM COLLAR	2
14	7.020.022	RR. BRAKE PAD SET	1
15	6.000.229	CALIPER ASSY. RR	1
16	7.010.032	CHAIN DISC GUARD	1
17	7.010.028	BATTERY COVER	1
18	7.020.023	BATTERY BAND	1
19	7.020.020	BATTERY LOWER CUSHION	1
20	6.000.085	BATTERY (YTX12-BS)	1
21	18-0626-00	RR. LOWER SWING ARM COMP.	1
22	9.220.012	LOCKING FLANGE NUT M12	2
23	7.020.008	SWING ARM CUSHION BUSHING	2
24	9.112.060	FLANGE BOLT M12x1.25x60	2

Upper Swing Arm

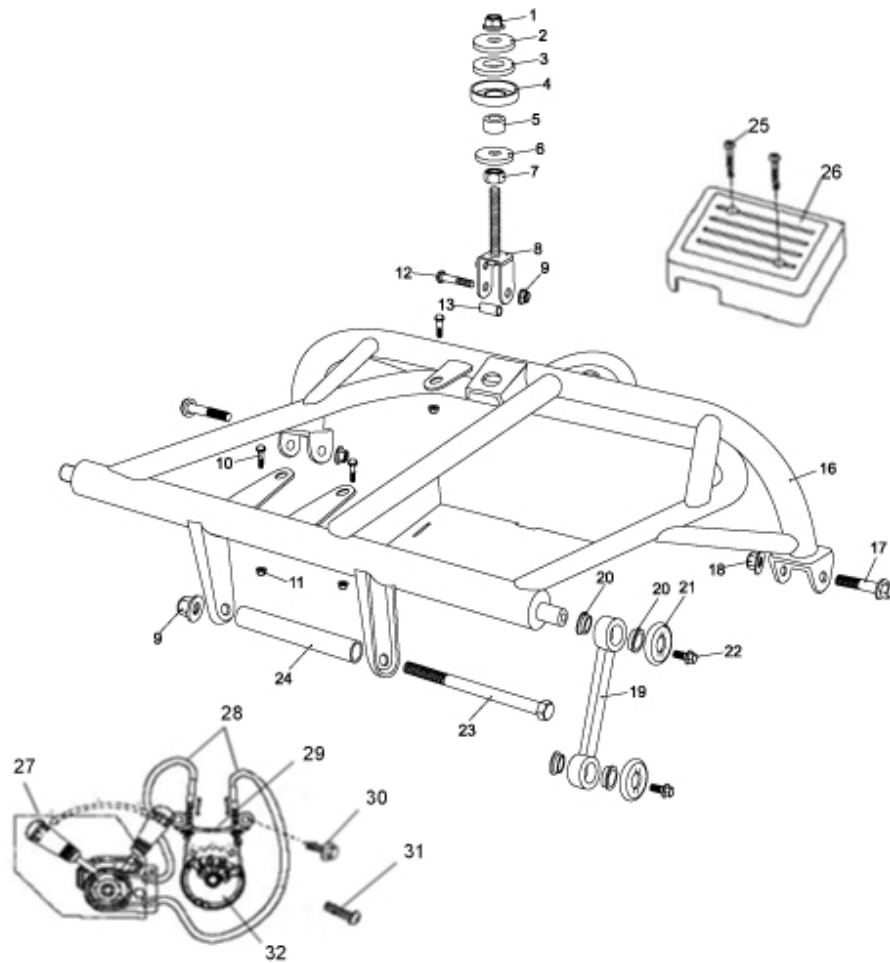

REF#	HH PART#	DESCRIPTION	PCS	REF#	HH PART#	DESCRIPTION	PCS
1	9.220.012	LOCKING FLANGE NUT. M12	1	17	9.112.060	BOLT-WASHER M12x1.25x60	2
2	8.010.042	WASHER. ENGINE MOUNT LINK	1	18	9.220.012	LOCKING FLANGE NUT. M12	2
3	7.020.001	CUSHION. ENGINE MOUNT LINK	1	19	8.030.001	SWING ARM DOG BONE	2
4	8.020.045	SPACER. ENGINE MOUNT LINK	1	20	7.010.008	BUSH. CON' ROD	8
5	8.010.041	COLLAR. ENGINE MOUNT LINK	1	21	8.020.013	SPACER. CON' ROD	4
6	9.300.012	WASHER. FLAT Φ12	1	22	9.108.016	BOLT-WASHER M8x1.25x16	4
7	9.200.012	NUT M12	1	23	9.710.195	BOLT-WASHER M10x1.25x195	1
8	6.000.026	ENGINE MOUNT BOLT PLATE	1	24	8.010.025	COLLAR. ENGINE MOUNT	1
9	9.220.010	LOCKING FLANGE NUT. M10	1	25	9.600.655	BOLT, M6 X 1.00 X 60 FHCS ZN	2
10	9.106.022	BOLT-WASHER M6x22	3	26	7.010.029	COVER, ELECTRICAL	1
11	9.210.008	LOCKING NYLON NUT. M6	3	27	14478	ASM, TRANS SHIFT LEVER - 150CC	1
12	9.110.045	BOLT-WASHER M10x1.25x45	1	28	18-0706-00	CABLE, D/N/R SHIFT - 150CC	2
13	8.010.076	COLLAR. ENGINE MOUNT BOLT PLATE	1	29	14473	BRACKET, SHIFT CABLE - 150CC	1
14	9.600.630	SCREW. PAN M6x30	2	30	M150-1003205	BOLT, M6 X 1.00 X 14 FHCS ZN	2
15	7.010.084	COVER. ELECTRIC ASS'Y.	1	31	9.106.020	BOLT, M6 X 1.00 X 20 FHCS ZN	1
16	2.000.062	REAR SWING ARM ASS'Y. UPPER	1	32	14479	DISC, SHIFT CONTROL - 150CC	1

Rear Axle

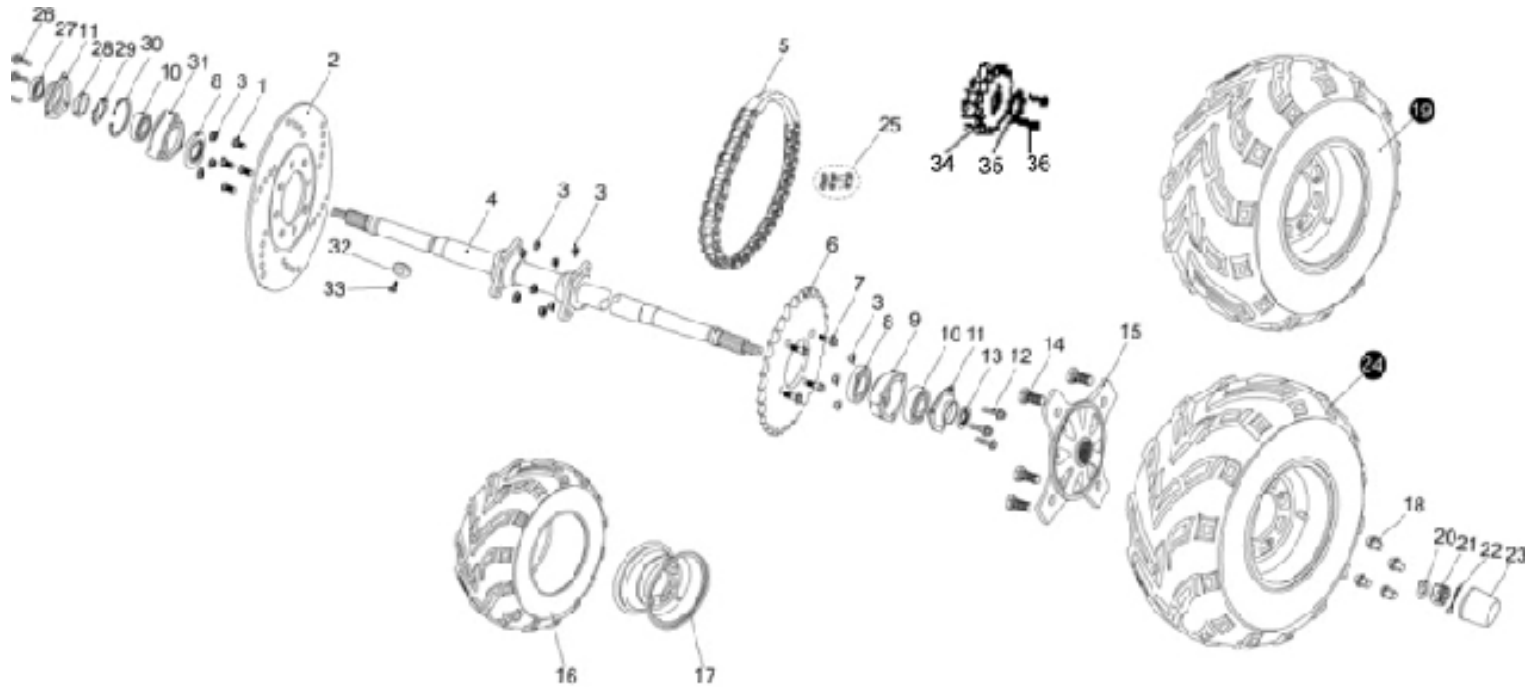

REF#	HH PART#	DESCRIPTION	PCS
1	9.108.022	BOLT-WASHER M8x1.25x22	4
2	8.010.053	DISC. RR. BRAKE	1
3	9.220.008	LOCK FLANGE NUT. M8	14
4	8.010.057B	REAR AXLE	1
5	9.070.002	CHAIN Double O-RING DRIVE.	1
6	008-40-000	REAR SPROCKET (41 teeth)	1
7	9.108.027	BOLT-WASHER M8x1.25x27	4
8	9.040.006	DUST SEAL 50X34-7	2
9	8.030.008	COMP. HOUSING RR. AXLE BRG	2
10	9.030.006	BEARING 6206	2
11	8.020.028	BEARING BASE	2
12	9.108.040	BOLT-WASHER M8x1.25x40	6
13	9.040.007	DUST SEAL 42X30-7	2
14	9.710.031	BOLT. TIRE M10x1.25x31	8
15	8.010.089B	HUB. REAR AXLE	2
16	14811	TIRE. RR 21x11-10	2
17	002-100100-B	RIM. RR 10" BLACK	2
18	8.010.118	LUG NUT. CAP M10	8

REF#	HH PART#	DESCRIPTION	PCS
19	18-0904-00	REAR. WHEEL ASSY. R	1
20	9.700.016	SPACER. RR. WHEEL 16	2
21	9.800.016	CASTLE NUT. M16	2
22	9.500.430	COTTER PIN. 4X30	2
23	7.020.039	COVER. RR. HUB	2
24	18-0902-00	REAR TIRE & WHEEL, Left	1
25	6.000.149	MASTER LINK. CHAIN	1
26	9.108.045	FLANGE BOLT M8X1.25X45	3
27	9.040.008	DUST SEAL 42X28-7	1
28	9.900.030	ROUND NUT M30X1.5	1
29	8.020.181	KEEPER	1
30	9.700.300	CIRCLIP Φ62	1
31	8.030.033	AXLE BRG HOUSING COMP.R	1
32	12.025.024	MAGNETIC CONTACT	1
33	12.025.025	EYE BOLT, M3X6	1
34	008-11-000	SPROCKET, DBL ROW 50P 11	1
35	8.020.181	KEEPER, SPROCKET	1
36	14296	BOLT, M6 X 1.00 X 12 FHCS ZN	2

Engine, Air Filter System

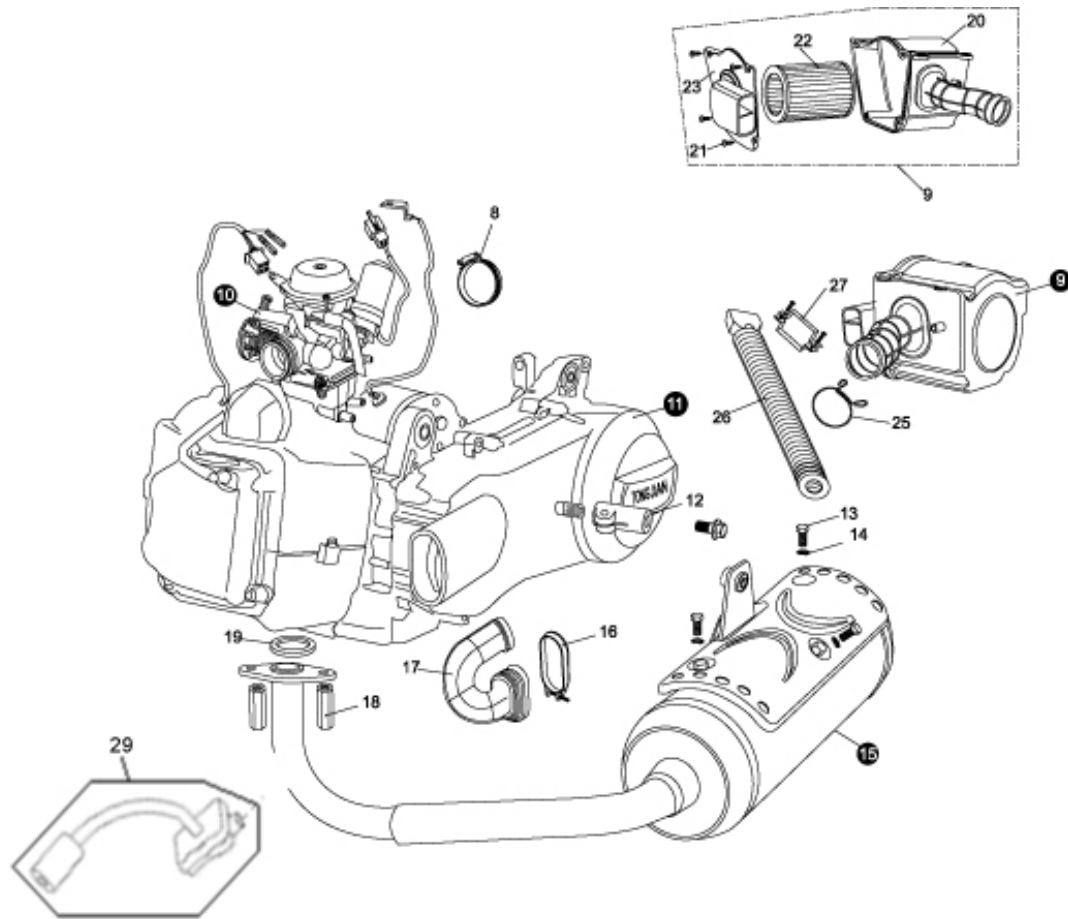

REF#	HH PART#	DESCRIPTION	PCS	REF#	HH PART#	DESCRIPTION	PCS
1	6.000.157	REVERSE ASSY.	1	16	8.020.055	BOOT CLAMP	1
2	8.010.122	INTERNAL COLLAR REVERSE	1	17	6.000.162	SIDE CASE BOOT	1
3	9.220.016	LOCKING FLANGE NUT M16	1	18	9.040.027	MUFFLER JOINT NUT, M6	2
4	9.106.012	FLANGE BOLT M6X12	2	19	9.040.005	EX PIPE GASKET	1
5	8.020.173	REVERSE BRACKET	1	20	7.010.047	AIR CLEANER CASE COMP	1
6	9.220.008	LOCKING FLANGE NUT M8	3	21	9.805.003	TAPPING SCREW, M5X16	4
7	9.908.040	BOLT STRAP, M8X1.25X40	1	22	6.000.151	AIR CLEANER ELEMENT	1
8	8.020.056	AIR CLEANER CLAMP	1	23	7.010.048	AIR CLEANER COVER	1
9	4.000.018	AIR CLEANER ASSY.	1	24	7.010.033	CHAIN PROTECTOR, RR.	1
10	6.000.024	CARBURETOR	1	25	8.040.013	AIR CLEANER CLIP	1
11	14531	ENGINE, 150CC	1	26	7.010.057	AIR CLEANER DUCT	1
12	8.030.037	MUFFLER RACK SUPPORT	1	27	8.020.176	AIR CLEANER CLAMP	1
13	9.100.612	BOLT, M5X16	3	28	9.108.040	FLANGE BOLT, M8X1.25X40	1
14	9.400.006	LOCKING WASHER $\phi 6$	3	29	14762	AIR INJECTION ASM, MUFFLER	1
15	6.000.074	MUFFLER COMP. EX	1				