



Solid-core DC Current Sensors IDCS-H



Strong points

Plug & Play
Wide selection of ratings
Simplified installation

Compliance with standards



Solid-core DC current sensors

DC current sensors - used with DC energy meter - from 500 A to 2500 ADC

Measures DC load current in electrical installations without disturbing wiring and transmits safe 500 mV and 471 mV auxiliary outputs to power monitoring devices via RJ11 or RJ45 modular connectors.

Function

- Engineered for accuracy and durability, they are suited to deliver precision current measurements in DC applications like renewable energy or transportation.
- Applications for DC measurements include battery monitoring, solar string and other systems that utilize DC power.
- The IDCS-H Series is compatible with Sensway AC/DC energy meters with optional CTid technology and requires a sensor hub.

Advantages

- Plug & Play
 - A quick RJ11 or RJ45 connection makes wiring easy and reliable.
 - Fast configuration of the sensor's rating.

Specification

Model Name (I:CTID technology model)

Rating Current

Maximum Current

IDCS-H500(I)	IDCS-H600(I)	IDCS-H800(I)	IDCS-H1000(I)
500A	600A	800A	1000A
750A	900A	1200A	1500A
IDCS-H1200(I)	IDCS-H1500(I)	IDCS-H2000(I)	IDCS-H2500(I)
1200A	1500A	2000A	2500A
1800A	2250A	3000A	3750A

Output Voltage

Base : $\pm 500\text{mV}$

Option : $\pm 471\text{mV}$ (I: CTID technology model)

1% at rated current(F.S) $R_L=10\text{K}\Omega$

Residual Voltage

Within $\pm 20\text{mV}$ (no load)

Noise Level

Less than 15 mVp-p(no load)

Output Linearity

$\pm 1\%$ rated current(F.S)

Hysteresis (FS \rightarrow 0)

Within $\pm 10\text{mV}$

Power Supply

DC +5V $\pm 5\%$ 40mA

di/dt Response Time

2 μsec (Typ.) at $di/dt=F.S/\mu\text{sec}$

Output voltage temperature coefficient

$\pm 0.08\%$ / $^{\circ}\text{C}$ typ

Residual voltage temperature coefficient

$\pm 0.095\text{mV}$ / $^{\circ}\text{C}$

Insulation Withstand Voltage

AC 1500V / 1min.

Insulation Resistance

DC 500V / 500M Ω max

Operating Condition

$-25^{\circ}\text{C}\sim+75^{\circ}\text{C}$, 85% RH non-condensing

Storage Condition

$-35^{\circ}\text{C}\sim+90^{\circ}\text{C}$, 85% RH non-condensing

Dimensions (mm)

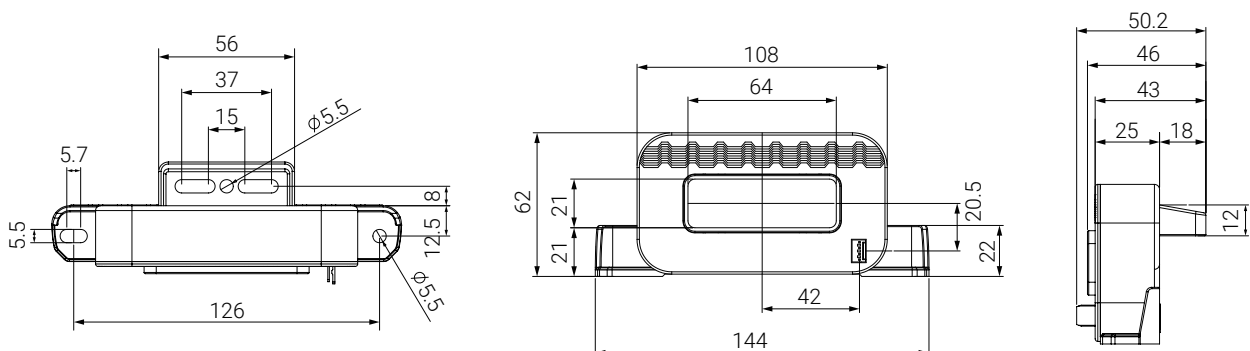

Powered Sensor Wiring Program

Output Voltage: $\pm 471\text{mV}$

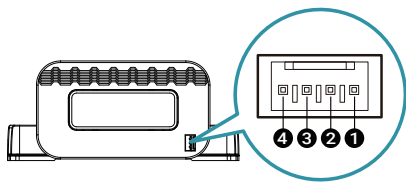
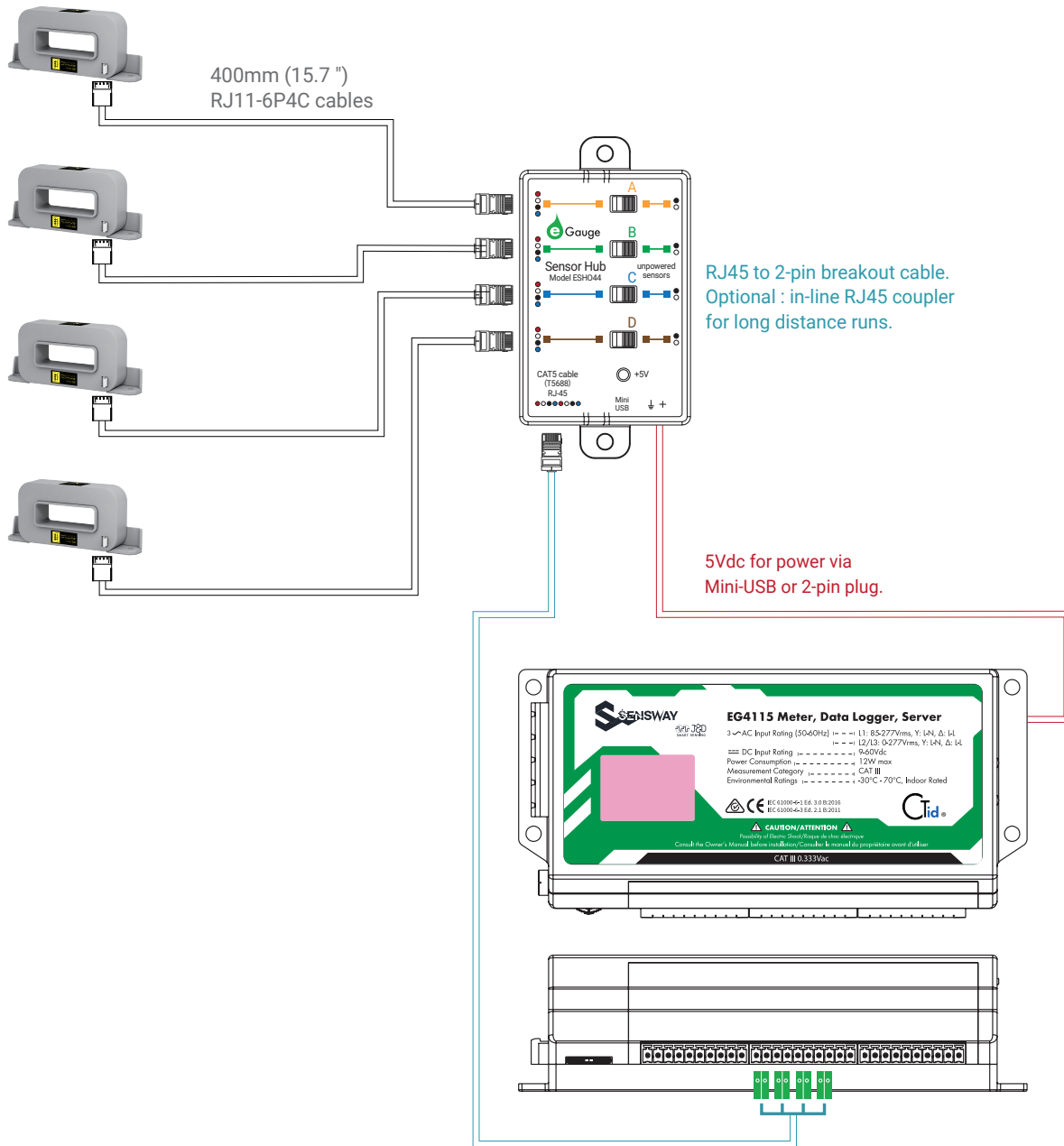

Connector :

Manufacturer	Molex
Part Number	38-00-6294 4P

Terminal Pin	Function
1	+5 V
2	OUTPUT
3	GND(Power Supply)
4	OUTPUT GND

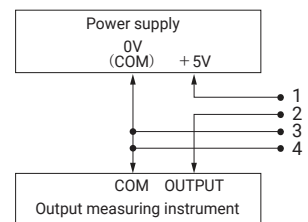

How to Connection

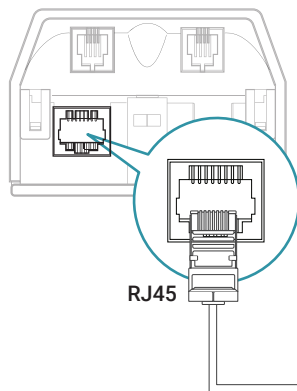
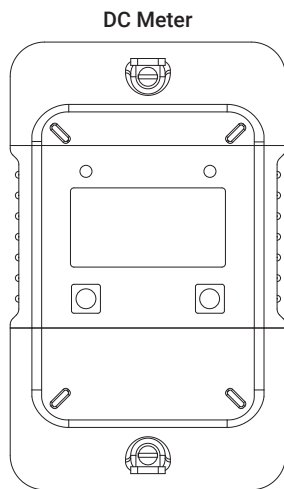
Output Voltage: $\pm 500\text{mV}$ 

RJ45

The prevalence of direct current (DC) systems is increasing, and their adoption in commercial and industrial environments is becoming more widespread. This has led to a growing demand for precise metering of DC systems.

The J&D DC Energy Meter DCS-I addresses this need by utilizing an external DC current sensor that uses high-precision Hall effect technology. The meter also has a built-in DC voltage sensor to continuously monitor the primary voltage. By regularly sampling these parameters, it calculates the cumulative energy consumption over a specific period of time, providing an accurate energy meter reading in kilowatt-hours (kWh).

• Click the link below to view detailed data.

<https://sensway.org/pages/dc-billing-meters>

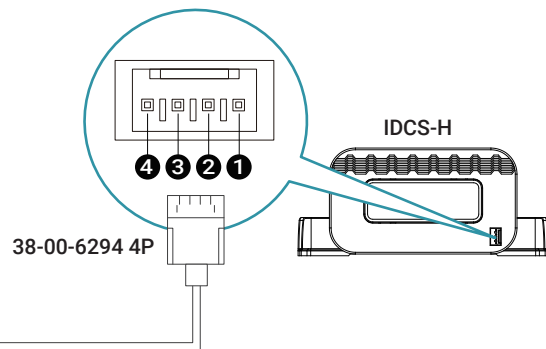

Terminal Pin	Function
①	+5 V
②	OUTPUT
③	GND(Power Supply)
④	OUTPUT GND

Connector :

Manufacturer	Molex
Part Number	38-00-6294 4P

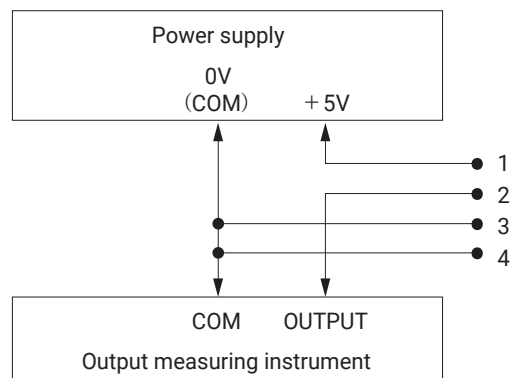

Safety & Danger Notes



The J&D CTs are UL/EN 61010-1, CE, RoHS compliant and certified, are also conformed up to Pollution degree 2, 600Vac CAT III rated devices.

Please be sure that Failure to follow these instructions can result in serious injury and/or cause damage. The transducer shall be used in electric/electronic equipment in accordance with the operating instructions of all related systems and component manufacturers with respect to applicable standards and safety requirements.

Follow corresponding national regulations and safe electrical work practices.

This equipment must only be installed and serviced by qualified personnel. And the qualified personnel is one who has skills and knowledge related to the construction and operation of this electrical equipment and installations, and has received safety training to recognize and avoid the hazards involved. In addition, the installation and maintenance shall be done with the main power supply disconnected except if there are no hazardous live parts in or in close proximity to the system and if the applicable national regulations are fully observed.



When operating the transducer, there may be dangerous active voltages (e.g. primary conductor) in certain parts of the module. Users should make sure to take all necessary steps to protect against electric shock. The transducer is a built-in device containing conductive parts that are inaccessible after installation.

Therefore, a protective enclosure or additional insulation barrier is necessary.

Safe and trouble-free operation of this converter can only be guaranteed if transport, storage and installation are carried out correctly and operation and maintenance are carried out carefully.

Remark

- I_o is positive when I_p flows in the direction of the arrow. (o : output, p : primary current)
- Temperature of the primary conductor should not exceed 100°C(212°F).
- Dynamic performances (di/dt and delay time) are the best with a single bar when the primary hole is completely filled.