

Split-core DC Current Sensors IDCS24P

DC/AC current sensor, IDCS24P series, applying with accurate laminating split-core technology and Open-Loop technology, has a strong durability and a good stability of error in low current and external vibration or shock.



Features

- One touch split core structure
- Isolation measurement CATIII
- Three Installation type: Panel mounting / DIN rail mounting / Cable tie mounting
- Insulating plastic case recognized under UL94-V0
- Complied with CE and RoHSIII

Applications

- Uninterruptible Power Supplies (UPS)
- Monitoring and measuring Power supplies for Telecom
- Switched Mode Power Supplies (SMPS)
- Battery supplied applications
- Chopper / Inverter monitoring
- DC Power Meter

Advantages

- Low power consumption with high accuracy
- Easy mounting by Split-core structure
- No insertion losses
- DC Immunity

Specification

SPEC	MODEL	IDCS24P -100	IDCS24P -150	IDCS24P -200	IDCS24P -250	IDCS24P -300	IDCS24P -400
Rating Current		100A	150A	200A	250A	300A	400A
Maximum Current		150A	225A	300A	375A	450A	600A
Output Voltage		±4 V, 0.5% at rated current(F.S) RL=10KΩ					
Offset Voltage		±20 mV max less than					
Noise Level		< 10mVp-p					
Output Linearity		±0.5% rated current(F.S)					
Hysteresis (FS→0)		±15mV					
Power Supply		±15V (±5%) 25mA					
di/dt Response Time		2 μ sec (Typ.) at di/dt=F.S/μ sec					
Output voltage temperature coefficient		Typ ±0.05% / °C Max ±0.6% / °C					
Residual voltage temperature coefficient		±0.5mV / °C					
Insulation Withstand Voltage		AC 1500V / 1min.					
Insulation Resistance		DC 500V / 500MΩ max					
Operating Condition		-25°C~+75°C, 85% RH non-condensing					
Storage Condition		-35°C~+90°C, 85% RH non-condensing					
Standard lead wire		400mm, 26AWG * 4C					

Split-core DC Current Sensors IDCS24P

Graphs

Output Voltage Characteristic

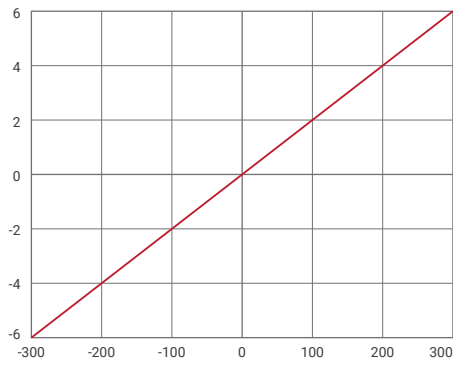

Frequency Characteristic

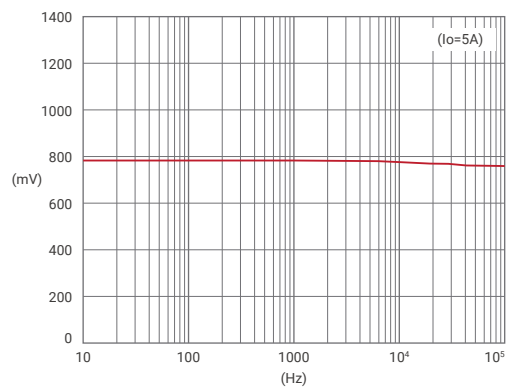

Output Wave-1

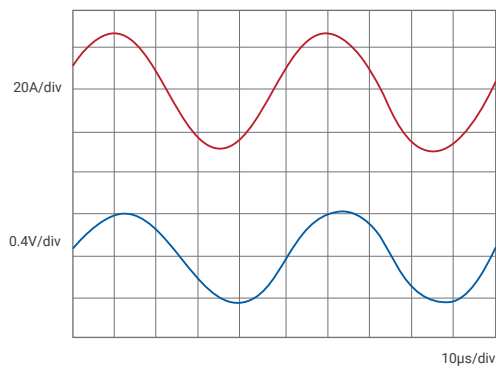

Output Wave-2

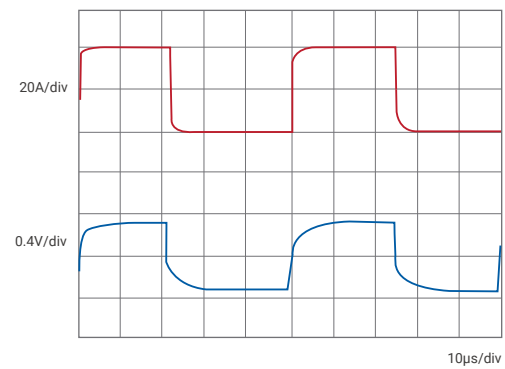

How to use

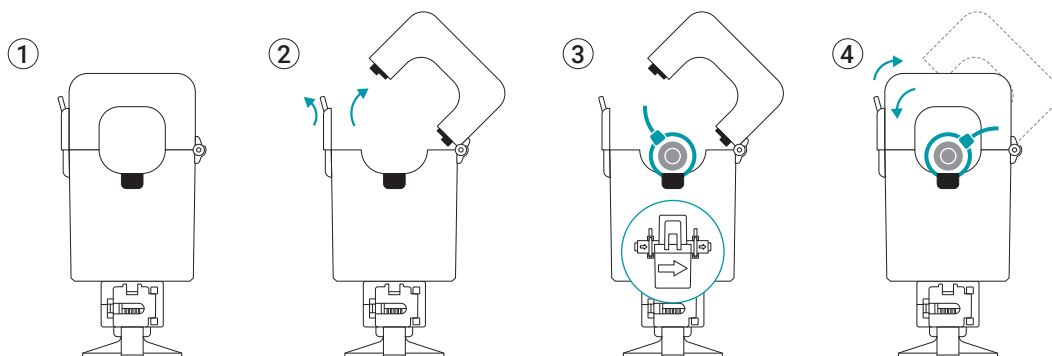

Split-core DC Current Sensors IDCS24P

Dimensions IDCS24P (in mm)

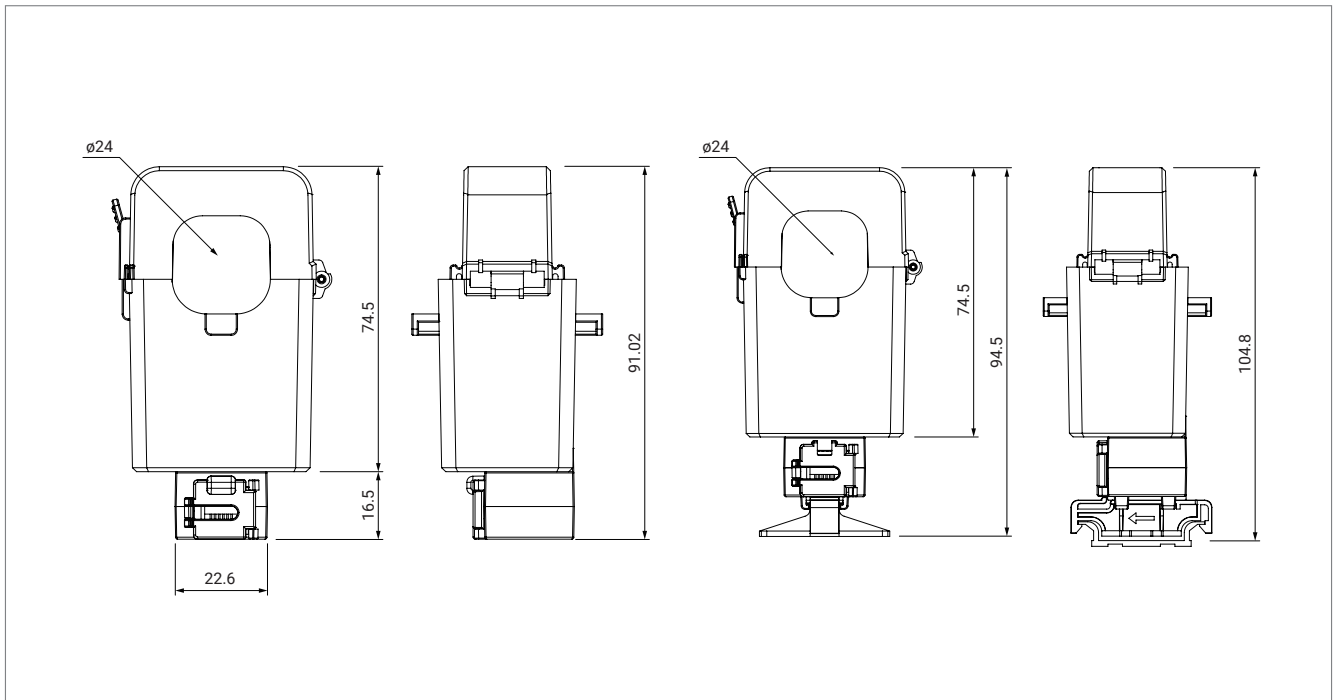

Connection Diagram

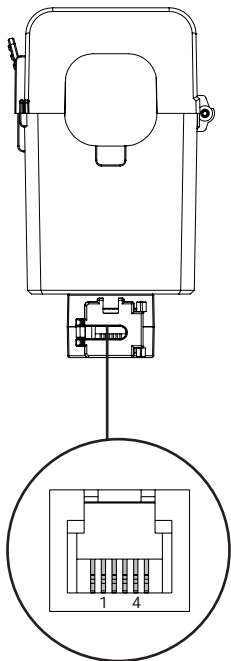

This product needs $\pm 15V$ (+15V and -15V DC bi-polar power supply) as operating power supply. Even if the case of detecting current with only plus direction, it still $\pm 15V$ needs. In any case, it is not possible to operate with only +15V

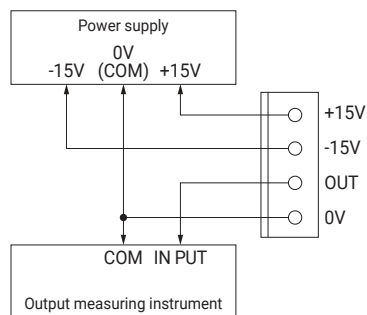

Terminal Pin	Function
1	+15 V
2	-15 V
3	OUTPUT
4	GND

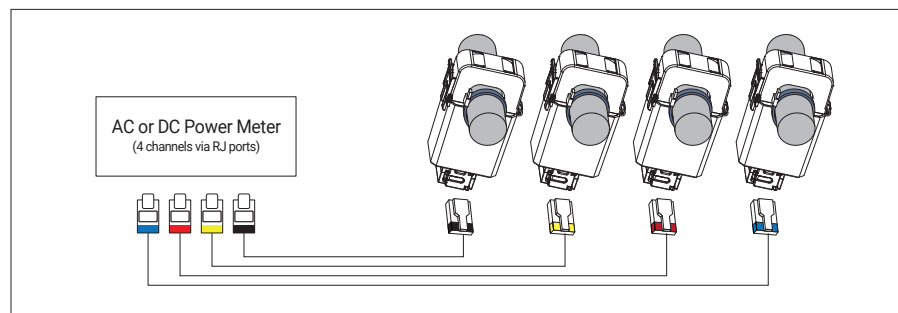

Connector	
Manufacturer	Wisdom
Part Number	DS-1149-4

Split-core DC Current Sensors IDCS24P

Mounting option

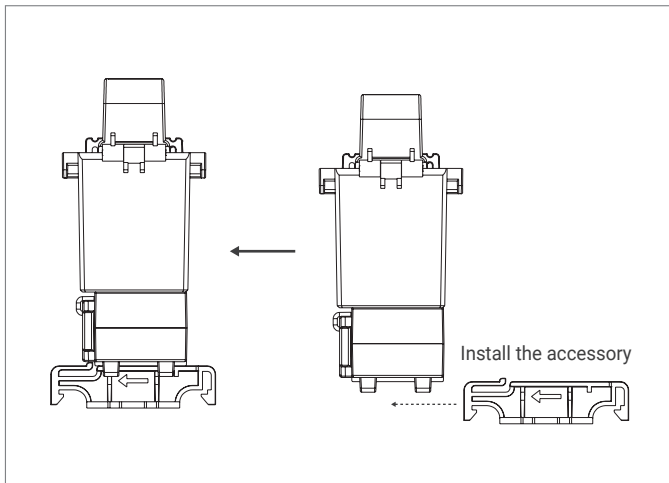

DIN rail mounting

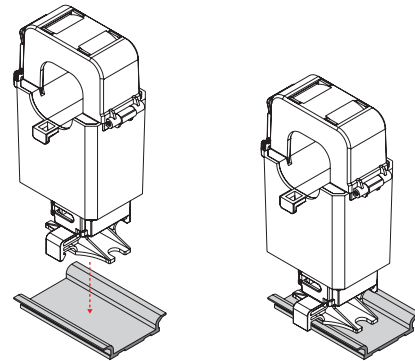

Panel mounting

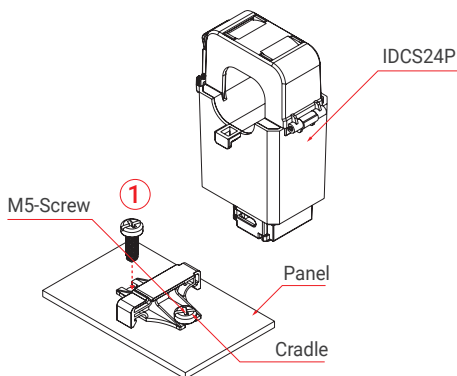

Place the cradle on the Panel and fix it via M5 screw.

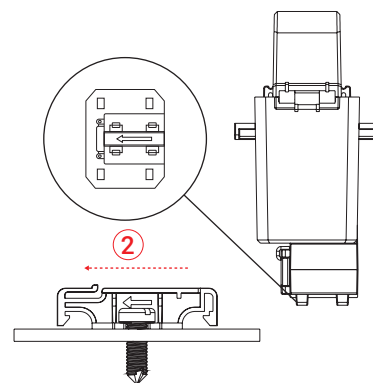

Install the product on the cradle, while matching the arrow direction of cradle and indication in the bottom of the product.

Cable tie mounting

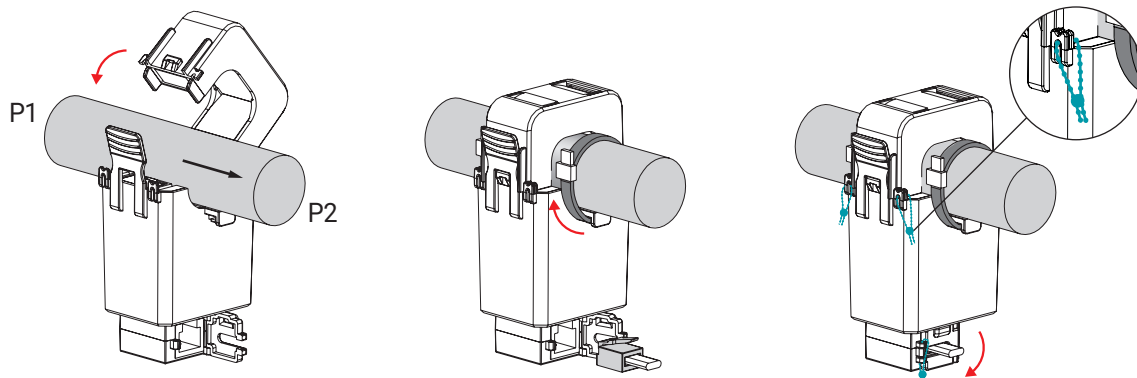

* Sealing for metering standards
(All types are available)

Split-core DC Current Sensors IDCS24P

Safety & Danger Notes

The J&D CTs are UL/EN 61010-1, CE, RoHS compliant and certified, are also conformed up to Pollution degree 2, 600Vac CAT III rated devices.



Please be sure that Failure to follow these instructions can result in serious injury and/or cause damage. The transducer shall be used in electric/electronic equipment in accordance with the operating instructions of all related systems and component manufacturers with respect to applicable standards and safety requirements.

Follow corresponding national regulations and safe electrical work practices.

This equipment must only be installed and serviced by qualified personnel. And the qualified personnel is one who has skills and knowledge related to the construction and operation of this electrical equipment and installations, and has received safety training to recognize and avoid the hazards involved. In addition, the installation and maintenance shall be done with the main power supply disconnected except if there are no hazardous live parts in or in close proximity to the system and if the applicable national regulations are fully observed.



When operating the transducer, there may be dangerous active voltages (e.g. primary conductor) in certain parts of the module. Users should make sure to take all necessary steps to protect against electric shock. The transducer is a built-in device containing conductive parts that are inaccessible after installation.

Therefore, a protective enclosure or additional insulation barrier is necessary.

Safe and trouble-free operation of this converter can only be guaranteed if transport, storage and installation are carried out correctly and operation and maintenance are carried out carefully.

Remark

- I_o is positive when I_p flows in the direction of the arrow. (o : output, p : primary current)
- Temperature of the primary conductor should not exceed 100°C(212°F).
- Dynamic performances (di/dt and delay time) are the best with a single bar when the primary hole is completely filled.