

## ARCT-XXX-M SERIES

The flexible Rogowski coil of the high-accuracy split-core current transformers offer significant installation advantages over the general split-core CT's because of their light weight, wide current(10-5000+ Amps), mechanical flexibility for mounting in tight quarters and easy placement around cable bundles or large busbars. Offered in 80, 115, 180, and 300 mm window sizes, the ARCT-M series is the most accurate Rogowski coil in submetering.



### Key Features

- In the following graphs, a positive phase angle error indicates that the output of the Rogowski coil CT with an integrator leads the primary current.
- Graphs show typical performance at 25°C, 50/60Hz
- Performance Graphs - The standard CT meets IEEE C57.13 class 0.6 standard & IEC 61869-2 class 0.5S standard



Model	Output(50Hz)	Output(60Hz)	One Loop Accuracy	Two Loop Accuracy
ARCT-080M	100 mVac	120 mVac	1	X
ARCT-115M	100 mVac	120 mVac	1	X
ARCT-180M	100 mVac	120 mVac	1	0.5S
ARCT-300M	100 mVac	120 mVac	1	0.5S

### How to Use



#### Option: Busbar mounting



Please refer to "Rogowski coil Current Transformer Installation Guide" for further details.

## 1. Specifications

- **Coil length** : 11.81 inches(30 cm) up to 118.11 inches(300 cm)
- **Window size** : 3.15 inches(80 mm) up to 11.81 inches(300 mm)  
(ex, ARCT-080-M, 080: 80mm, 115: 115mm, 180: 180mm, 300: 300mm)
- **Cord diameter** : 8 ±0.2 mm
- **Weight** : 150 - 500 g
- **Output level (RMS)** : 100 mV / kA @ 50 Hz, 120 mV / kA @ 60 Hz
- **Max measurable current** : 2 kA @ 50/60 Hz with 30 ... 42 cm coil length  
5 kA @ 50/60 Hz with 43 ... 300 cm coil length
- **Coil resistance** : 70 - 900 Ohms
- **Positioning error** : One loop → < 0.8% of reading  
Two loop → < 0.25% of reading

- Frequency : 40 Hz - 5 kHz
- Overvoltage category : CAT IV 600 Vrms, Service Entrance
- Pollution degree : 2, Controlled Environment
- Insulation test voltage : 7400 Vrms / 1 min
- Connection cable : 2 x AWG18 shielded, double insulated, standard length 1.5 m (option 2 m - 15 m)
- Protection degree : IP20
- Altitude : up to 2000 m over sea-level
- Operating temperature : -40 °C - +75 °C for coil with 2 kA max measurable current  
-40 °C - +60 °C for coil with 5 kA max measurable current
- Storage temperature : -40 °C - +90 °C
- Relative humidity tolerance : 0 - 95%
- Installation and use : Controlled environment, Indoor
- IEC, UL standards : IEC 61010-1, IEC 61010-2-032, UL 61010-1

## 2. Output Accuracy

- Ratio Error :  
Accuracy 0.5% conforms to IEC 61869-2 & IEEE/ANSI C57.13 meets the measuring range from 5% to 120% of rated current
- Phase Angle :  
50/60 Hz - 0.0 to 0.5 degrees leading from 5% to 120% of rated current

## 3. Dimensions

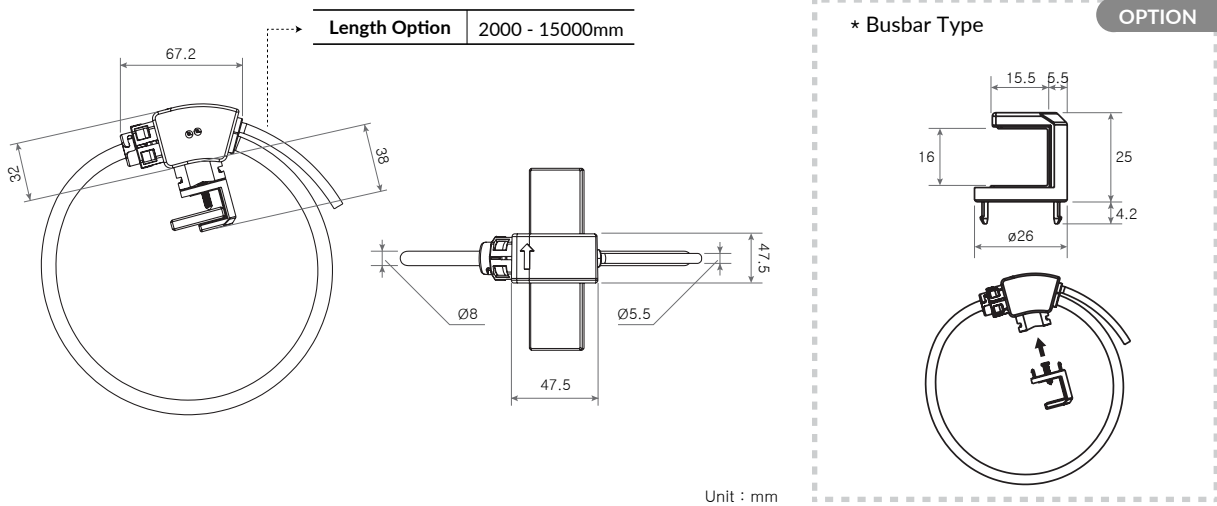

### Connection

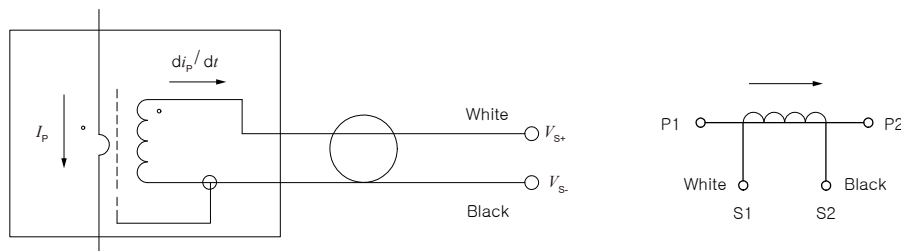

## 4. Typical Accuracy

- In the following graphs, a positive phase angle error indicates that the output of the Rogowski coil CT with an integrator leads the primary current.
- Graphs show typical performance at 25°C, 50/60Hz
- Performance Graphs – The standard CT meets IEEE C57.13 class 0.6 standard & IEC 61869-2 class 0.5S standard

### 4.1 ARCT-080-M Series with an integrator(of C, M, S and T type) (Rated current: 500A/333mV)

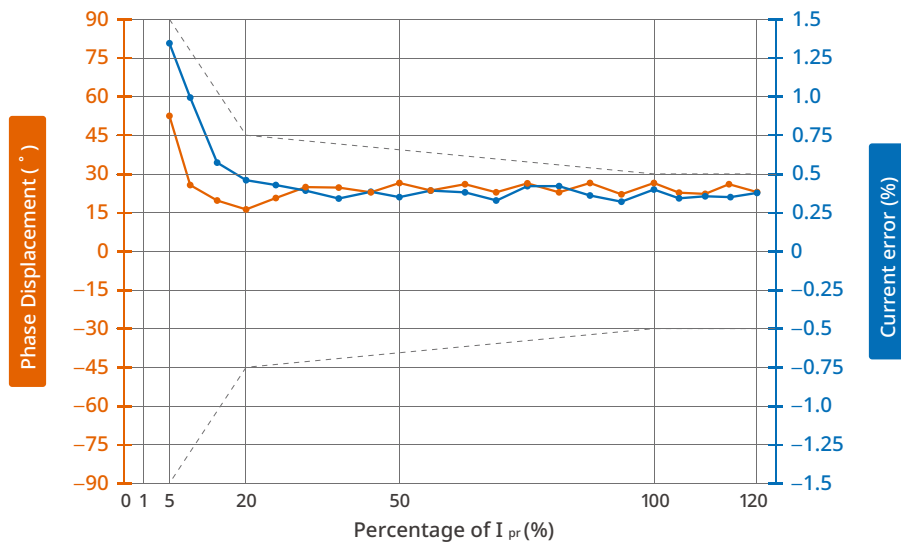

Only meets IEC 61869-2 Class 1.0 at rated currents greater than 500 A.

### 4.2 ARCT-115-M Series with an integrator(of C, M, S and T type) (Rated current: 1000A/333mV)

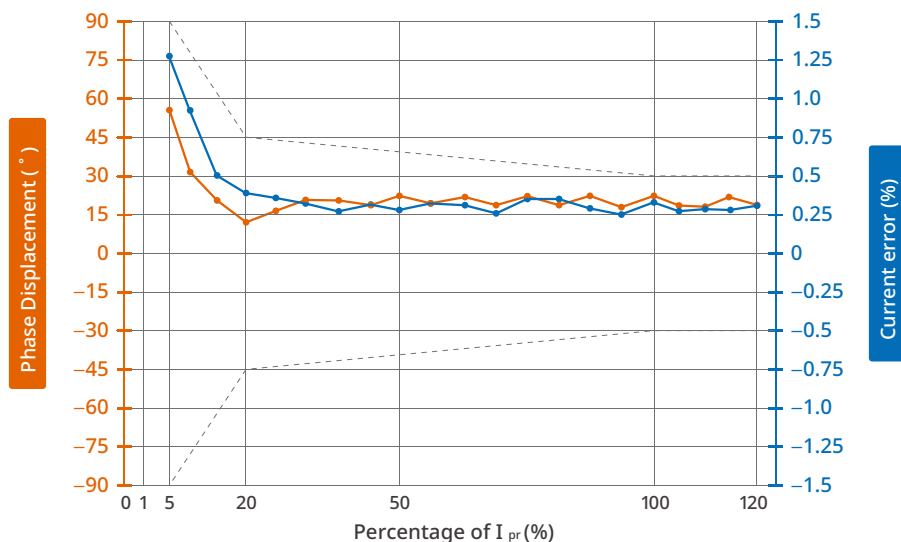

Only meets IEC 61869-2 Class 1.0 at rated currents greater than 1000 A.

**4.3 ARCT-180-M Series**  
**with an integrator(of C, M, S and T type) two-loop (Rated current: 2000A/333mV)**

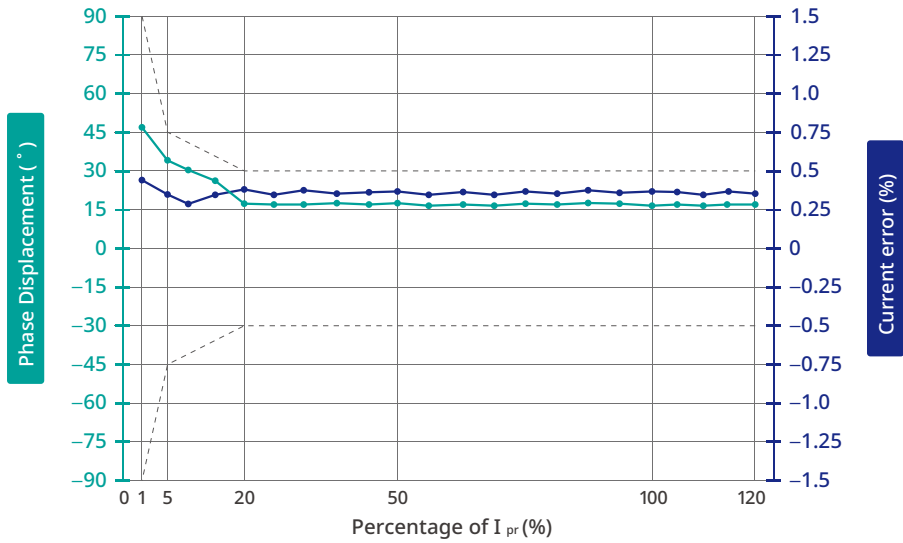

Only meets IEC 61869-2 Class 0.5S at rated currents greater than 2000 A.

**4.4 ARCT-300-M Series**  
**with an integrator(of C, M, S and T type) two-loop (Rated current: 3000A/333mV)**

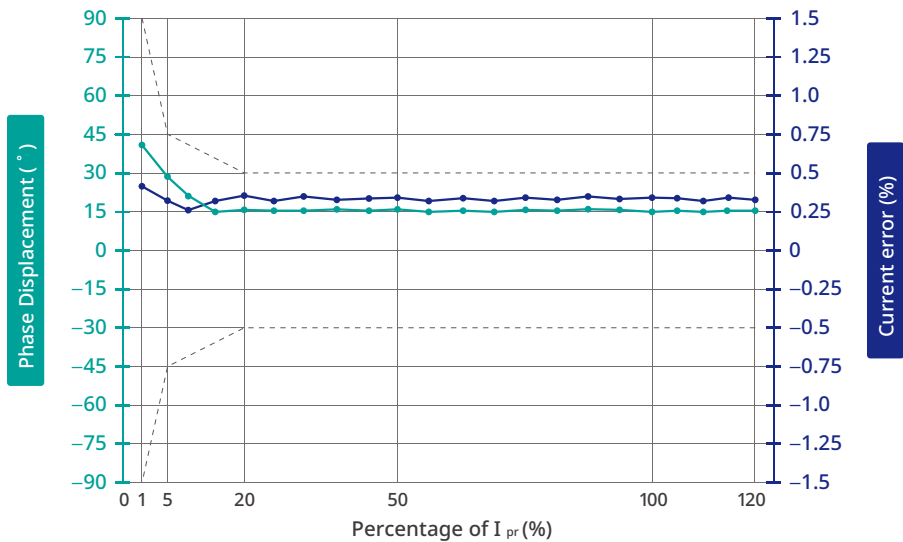

Only meets IEC 61869-2 Class 0.5S at rated currents greater than 3000 A.

## 5. Option - External Integrators

### 5.1 C Type

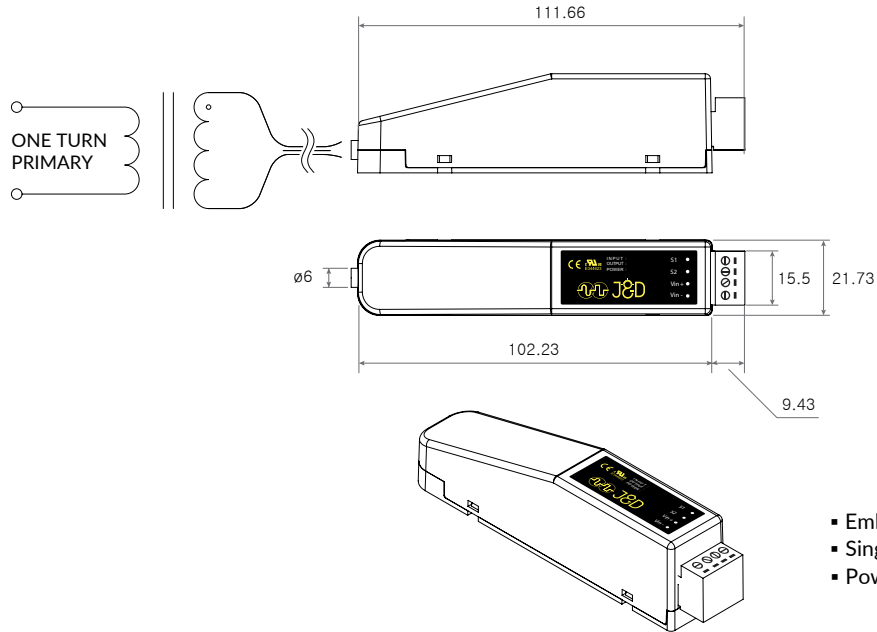

- Embedded type
- Single-phase
- Power supply : +24Vdc

### 5.2 M Type

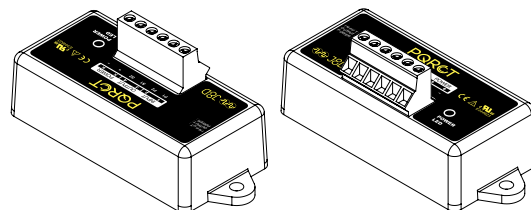
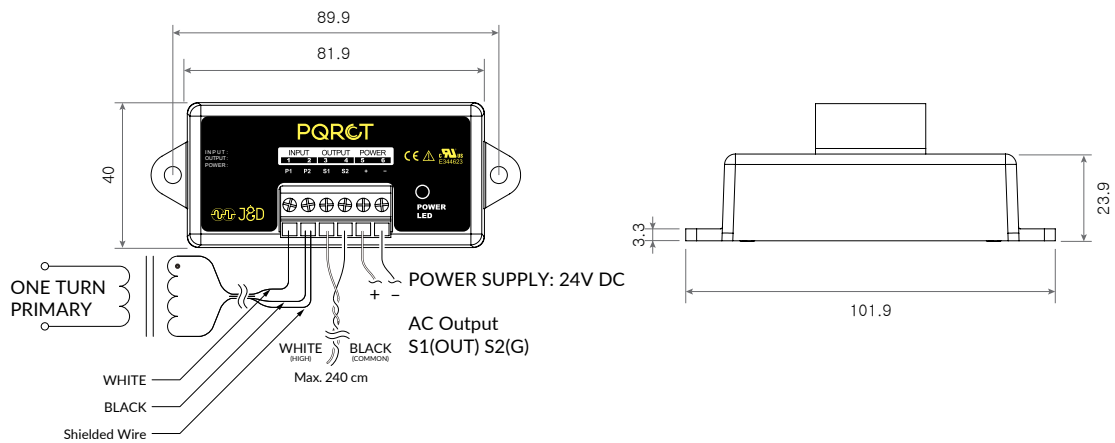

- Wiring type
- Single-phase
- Power supply : +24Vdc

5.3 S Type

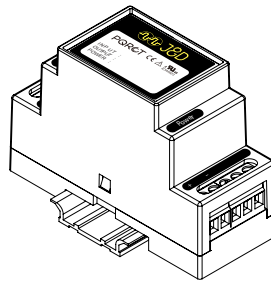
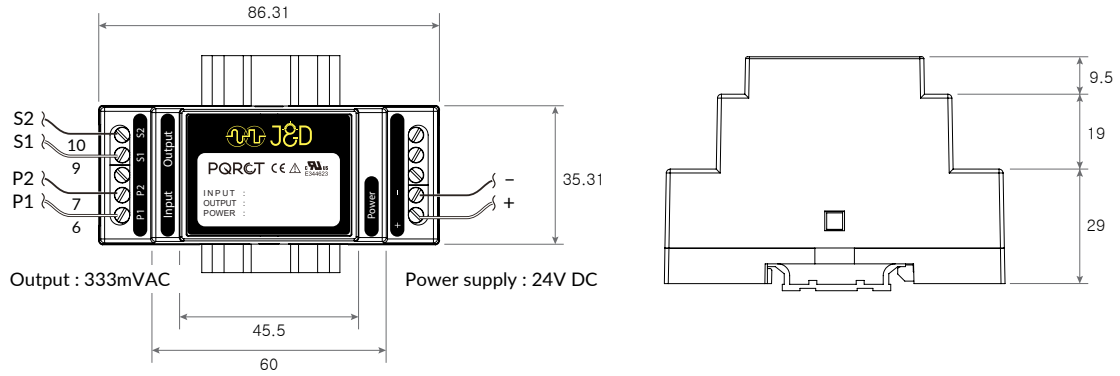

- Wiring type
- Single-phase
- Power supply : +24Vdc

5.4 T Type

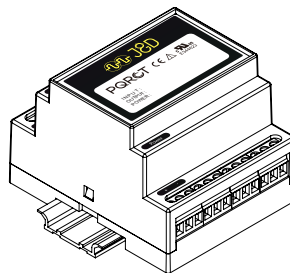
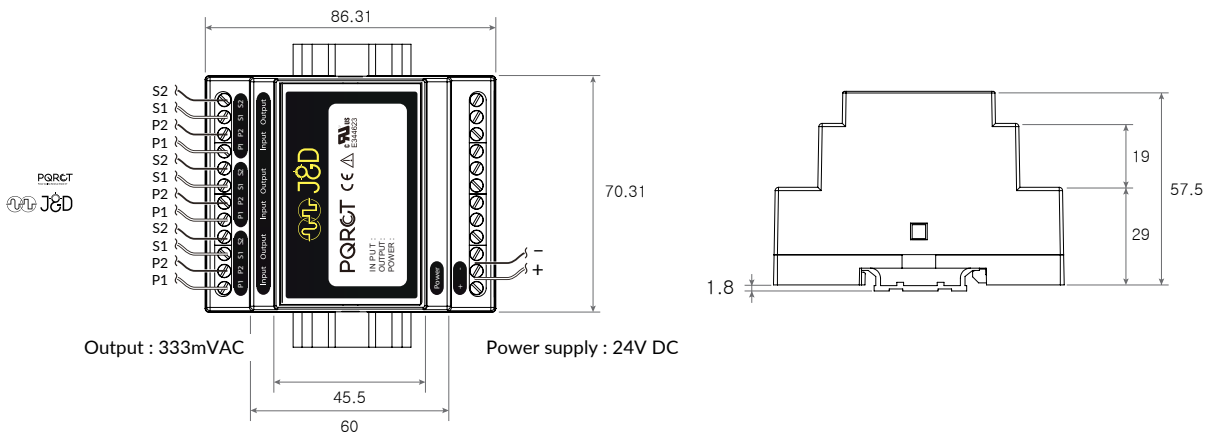

- Wiring type
- Three-phase
- Power supply : +24Vdc

## 6. Safety

The J&D CTs are UL/EN 61010-1, CE, RoHS compliant and certified, are also conformed up to Pollution degree 2, 1000Vac CAT III, 600V CAT IV rated devices.



Please be sure that Failure to follow these instructions can result in serious injury and/or cause damage.

The Rogowski coil current transducer shall be used in electric/electronic equipment in accordance with the operating instructions of all related systems and component manufacturers with respect to applicable standards and safety requirements.

Follow corresponding national regulations and safe electrical work practices.

This equipment must only be installed and serviced by qualified personnel. And the qualified personnel is one who has skills and knowledge related to the construction and operation of this electrical equipment and installations, and has received safety training to recognize and avoid the hazards involved.



When operating the Rogowski coil current transducer, there may be dangerous active voltages (e.g. primary conductor) in certain parts of the module. Users should make sure to take all necessary steps to protect against electric shock. The Rogowski coil current transducer is a built-in device containing conductive parts that are inaccessible after installation.

Therefore, a protective enclosure or additional insulation barrier is necessary.

Safe and trouble-free operation of this converter can only be guaranteed if transport, storage and installation are carried out correctly and operation and maintenance are carried out carefully.

## 7. Remark

- $V_o$  is positive when  $I_p$  flows in the direction of the arrow. (o : output, p : primary current)
- Temperature of the primary conductor should not exceed 80°C(176°F).
- Dynamic performances (di/dt and delay time) are the best with a single bar when the primary hole is completely filled.