

QUANTUM V3



CHILLOUT
SYSTEMS



REGISTER YOUR SYSTEM

To activate your warranty, products must be registered within 30 days of purchase. Scan the QR code to begin the process or enter the link below.

chilloutsystems.com/pages/product-registration



INCLUDED

- 1x Quantum V3 Cooler
- 1x Wiring loom
- 1x Carbon fiber baseplate
- 2x Quick release pins
- 4x Rubber isolaters

SPECIFICATIONS



RATED COOLING CAPACITY
300 watts



WORKING VOLTAGE
12V/24V



MAX CURRENT
30A/15A



COMPRESSOR
Micro Brushless Inverter
Rated Voltage: 24V
Displacement: 1.9cc



FAN
Axial Flow
Rated Voltage: 24V



PUMP
Rated Voltage: 24V
Max Flow: 20L/min



RESEVOIR
Volume: 130ml



SIZE
Length: 10.74in / 273mm
Width: 6.49in / 165mm



WEIGHT
Cooler: 10.14lbs / 4.6kg
Mounting Plate: 1.98lbs / 0.9kg



OPERTATING TEMPERATURE
32°F - 130°F / 0°C - 54.4°C



STORAGE TEMPERATURE
14°F - 140°F / 0°C - 60°C



SYSTEM DISPLAY

The Quantum V3 Cooler can be controlled via the buttons on the system or by wired remote (sold separately). Lights at the top of the display indicate the set temperature settings controlled by the "+" and "-" keys.

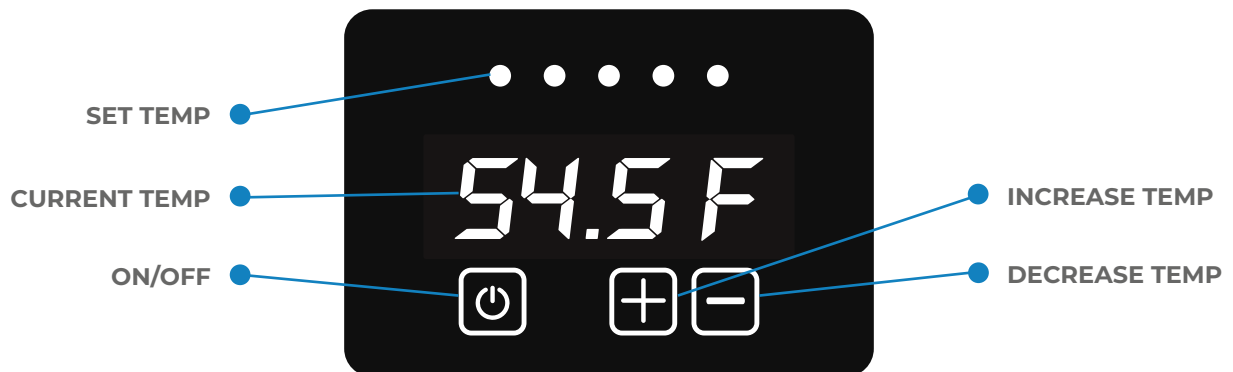

BUTTON SETTINGS



ON/OFF
Long press (2 seconds) to turn the system On/Off.



INCREASE SYSTEM TEMPERATURE
Short press the button to increase the fluid temperature in increments of 5 degrees fahrenheit. Set Temperature will display for 2 seconds before returning to the current system temperature.



DECREASE SYSTEM TEMPERATURE
Short press the button to decrease the fluid temperature in increments of 5 degrees fahrenheit. Set Temperature will display for 2 seconds before returning to the current system temperature.

Note: To switch between displaying Celsius and Fahrenheit, long press (2 seconds) the "+" and "-" keys while the system is powered off.

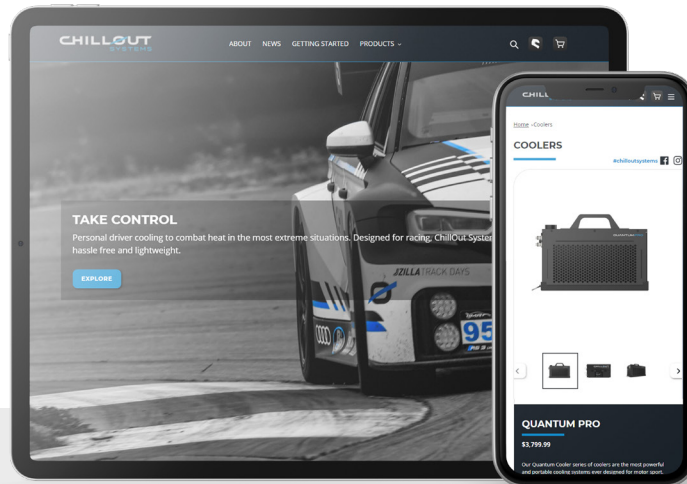

FREQUENTLY PAIRED TOGETHER

Remote Control (V3/PRO)

Pro Touring Cooling Shirt

Rapid Release Kit

Coolant Formula (1.5L)

10ft Insulated Coolant Hose

4" Carbon Fiber 90° Air Plenum

4" Carbon Fiber NACA Duct

4" Neoprene Air Duct Hose

MOUNTING THE BASEPLATE



- Determine the best location to mount your system inside the car. If possible, keep your system away from any heat sources to ensure maximum cooling efficiency. Ensure there is a sufficient gap between the back of the unit so that the air can circulate freely.
- Place the systems base plate where you have decided to install it and use a sharpie to mark the holes for installation into the vehicle.
- Drill out the holes so that you can install the rivnuts to the vehicle. Once the rivnuts are installed, you can attach the base plate to the vehicle. Be sure to install the provided rubber isolators between the base plate and the installed rivnuts to keep airflow underneath the unit.
- With the base plate now installed, insert the system into the plate and secure with the 2 ball pin connectors.

DUCTING AND PLENUMS



When installing a NACA duct and plenum, consider using ChillOut Systems 4 inch ducting and plenums. With nearly twice the airflow as 3 inch ducting, this is the most efficient way to keep your system cool. In some cases 3 inch ducting may be the only option. In this case, the system must be paired with a in-line 3 inch blower that is rated to 275 cfm..

- Place the NACA Duct where you have decided to install it and use a sharpie to trace an outline to the vehicle. Once the outline has been traced onto your window, a rotary cutting tool can be used to cut out the outline. We recommend using M4 nuts and bolts to secure the naca duct to a lexan window.

INSTALLING THE WIRING



- Connect the wiring harness to the system and run it to your electrical source. This can be directly to the battery with an inline fuse or to a 40amp relay if you are using a switch for the install.
- Once you figure out the length of wire required you can trim the excess and connect it accordingly. (Our wiring harness uses 8 AWG wire)
- Connect the remote wire to the system if you have purchased a remote. We recommend putting the remote somewhere that sun won't directly glare onto it (This can make it hard to read while driving).

CONNECTING THE SHIRT



- If you are using a dual prong connector, run the insulated hose from the system to where the driver seat is, making sure there is enough slack to reach the drivers shirt comfortably.
- If you are using **Chillout Systems Rapid Release Kit**, you can either cut and install it to a regular insulated hose or use our Insulated Y-Split Hose.
- When using a Y-Split hose, we recommend keeping a dual prong connector on one side of the seat and installing the rapid release on the opposite side giving you both options in the car for connecting the shirts to the system.

FILLING THE RESERVOIR



- Mix 1 part *Chillout Systems Coolant Formula* to 4 parts deionized water (1:4)
- Open the cap and slowly pour into the reservoir until the fluid is visible in the filling port. Be mindful of the pouring speed and do not let the liquid overflow.
- Press and hold the power button on the display for 2 seconds to power on the system. You will need to top up the fluid as it cycles through the system until visible again in the filling port.
- When turning the system on for the first time, the fluid level will decrease due to the systems internal lines containing no fluid.

*Note: If you are using an alternative antifreeze solution, its viscosity at 40°F / 25°C should not exceed 2.2mPa·s. Purified water is also suitable fluid for the system if *Chillout Systems Coolant Formula* is not available.*

SYSTEM FAULT CODES



If the system experiences a fault, it will automatically shut down. The fault code will appear on the systems display.

(E1) Temperature Sensor Failure

The systems temperature sensor has an error or the systems temperature has exceeded its monitoring range (-22~ 392°F/-30~200°C).

(E2) Flow Alarm

No flow of fluid detected through the circuit.

Note: The system has a low-voltage protection function. If the vehicles battery is used as the power supply and the input voltage is lower than the protection voltage (9V~10V), the system will automatically shut down. When the power supply voltage returns to normal, the host will automatically turn on after 30 seconds.

Note: The system also has a overcurrent protection function. If the current is greater than the protection current (about 35A), the system will automatically shut down. After the current protection occurs, the system will need to be powered on manually

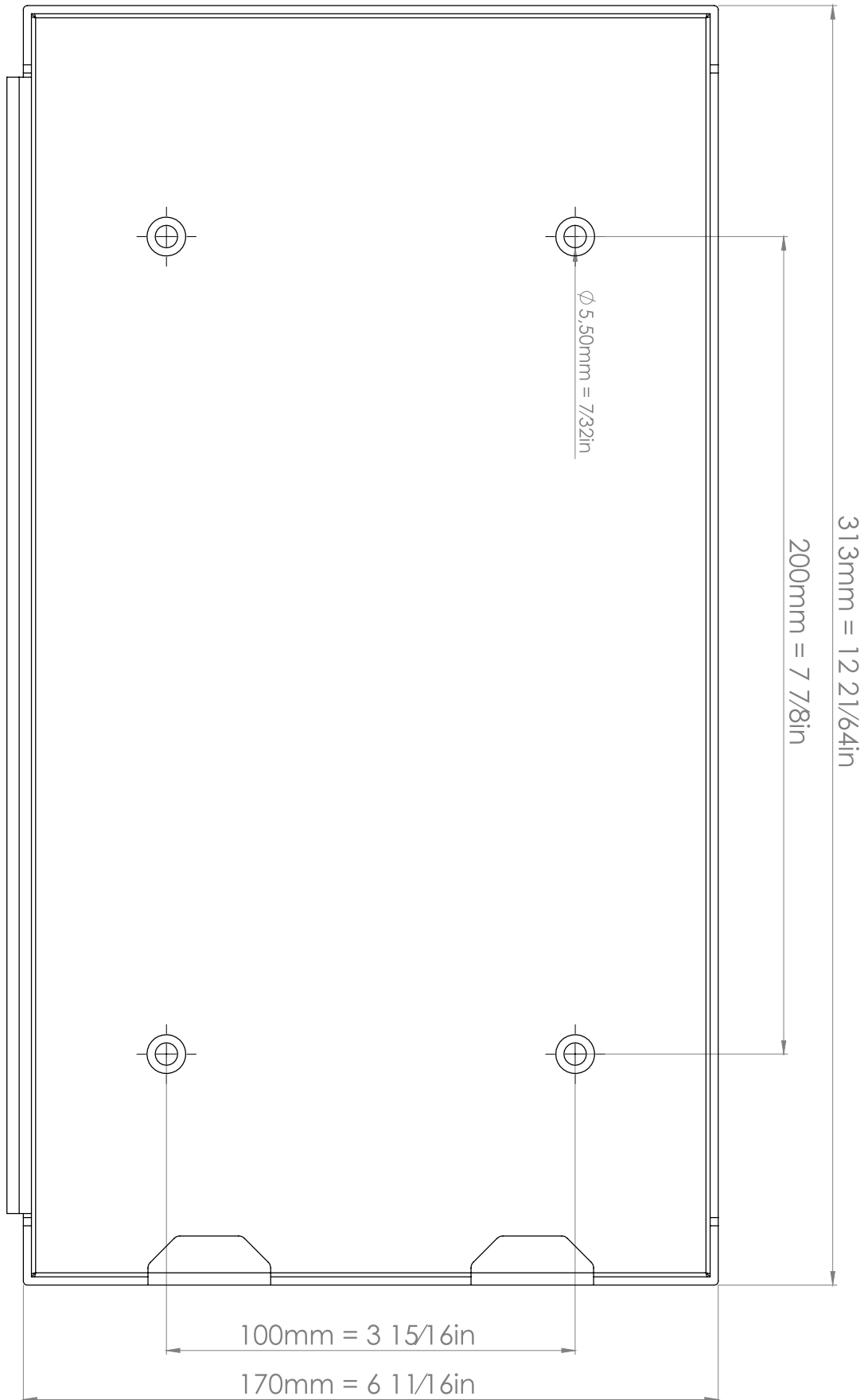

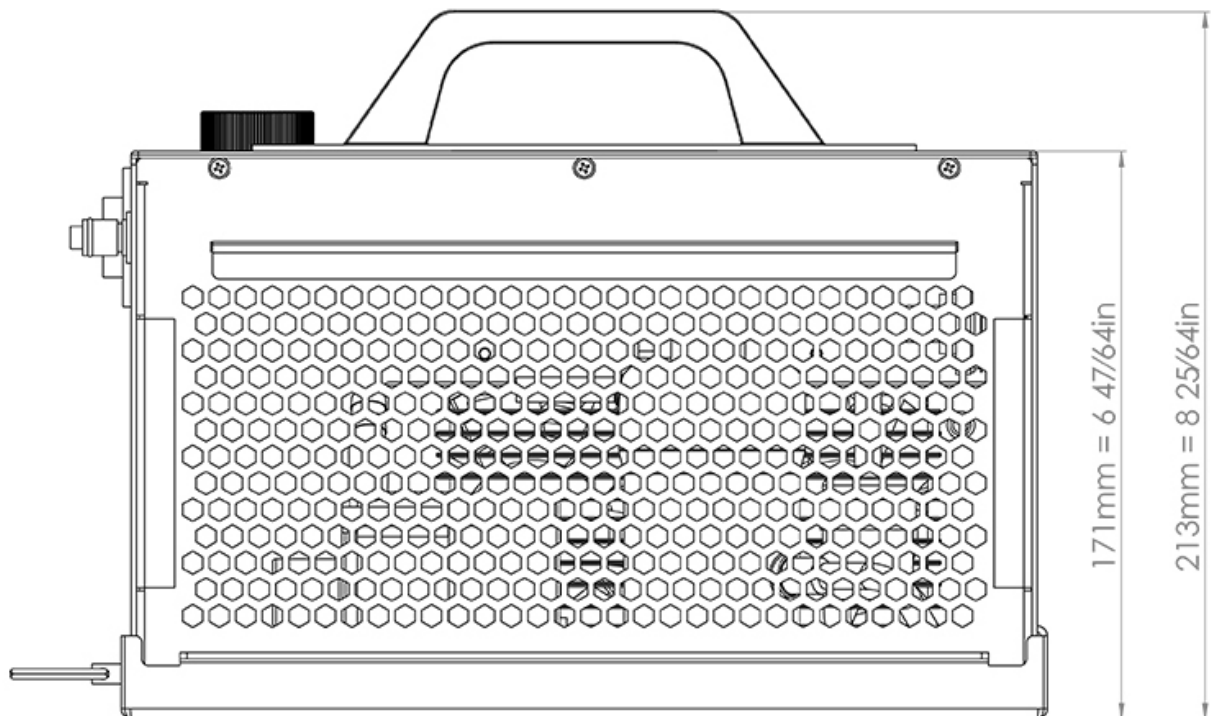
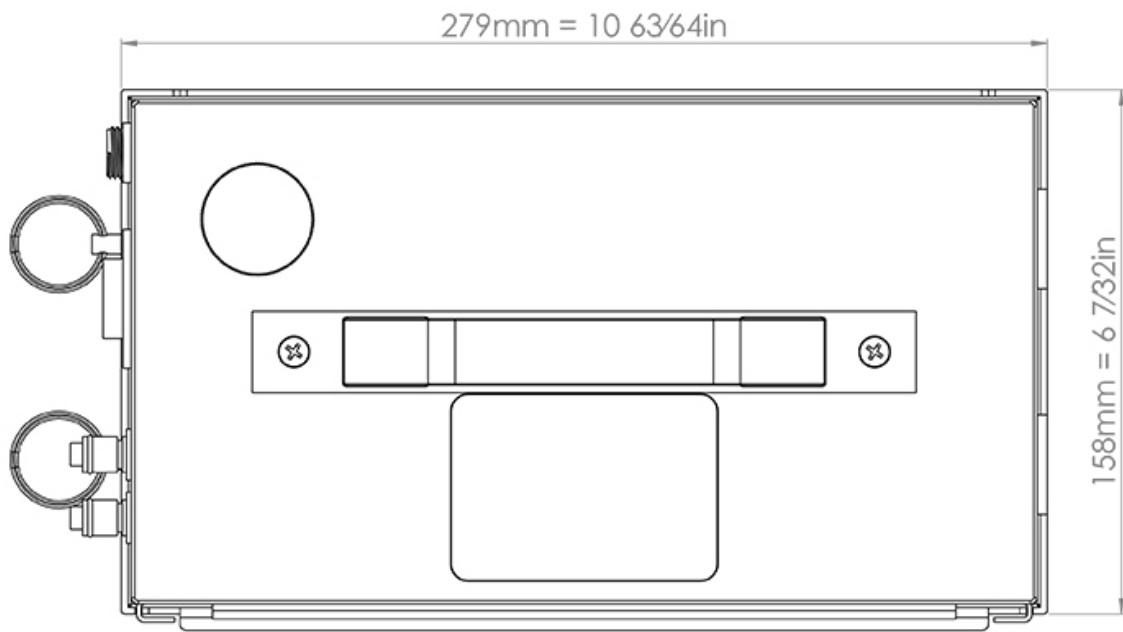



EXTEND YOUR PRODUCTS WARRANTY

Chillout Service gives you the peace of mind of an additional 2 years to your systems warranty period (36 months total). This includes one free service at any time during the 36 month warranty period.

SERVICING

- Deep cleaning of all internals (includes fans, condenser, controller boards).
- Servicing of the cooling system.
- Freon pressure check and top-up (if necessary).
- Performance checks and optimization.

REPAIR/REPLACEMENT

In the unlikely event of a failure to your system, within your extended warranty we will expedite a replacement cooler to you via Express Air Service.

Your system will be diagnosed, serviced, repaired and sent back to you.



CHILLOUT
SYSTEMS

QUANTUM V3

