



# DFK 39GX265-Z20 Technical Reference Manual

# Table of Contents

## 1 Quick Facts 5 Dimensional Diagrams 7

2.1	DFK 39GX265-Z20 Zoom Camera with Tripod Adapter.....	7
-----	--	---

2.2	DFK 39GX265-Z20 Zoom Camera without Tripod Adapter.....	8
-----	---	---

3.1	6-pin I/O Connector.....	9
3.1.1	TRIGGER_IN .....	9
3.1.2	STROBE_OUT .....	10

## 4. Spectral Characteristics 11

4.1	Spectral Sensitivity - IMX265LQR-C.....	11
-----	---	----

## 5. Camera Controls 12

5.1	Sensor Readout Control.....	12
-----	-----------------------------	----

5.1.1	Pixel Format .....	12
5.1.1.1	8-Bit Bayer .....	12
5.1.1.2	12-Bit Raw.....	12
5.1.1.3	16-Bit Bayer Raw.....	13
5.1.1.4	16-Bit Bayer Raw.....	13
5.1.1.5	4:2:2.....	13
5.1.1.6	YUV Resolution .....	14
5.1.2	4:1:1 Readout Modes .....	14
5.1.3	RGB24 Frame Rate .....	15
5.1.4	Partial Scan Offset .....	17
5.1.5	Image Flipping .....	18

5.2	Image Sensor Control.....	19
-----	---------------------------	----

5.2.1	Exposure Time .....	19
5.2.2	Gain .....	19
5.2.3	Black Level .....	19

5.3	Automatic Exposure and Gain Control.....	20
-----	--	----

5.3.1	Auto Exposure .....	20
5.3.2	Auto Gain .....	21
5.3.3	Auto Reference Value .....	21
5.3.4	Highlight Reduction .....	21
5.3.5	Auto Exposure Limits .....	22
5.3.6	Auto Gain Limits .....	22

5.4	Lens Control.....	23
-----	-------------------	----

5.4.1	Zoom .....	23
5.4.2	Focus .....	23
5.4.3	Iris .....	24
5.4.4	Infrared Cut Filter .....	24

# Table of Contents

5.4.5Auto Focus .....	25
5.4.6Auto Focus ROI .....	25
5.4.7Auto Iris .....	26
<b>5.5Trigger.....</b>	<b>27</b>
5.5.1Trigger Mode .....	27
5.5.2Trigger Polarity .....	27
5.5.3Software Trigger .....	27
5.5.4Trigger Burst Count .....	28
5.5.5Trigger Source .....	28
5.5.6Trigger Overlap .....	28
5.5.7IMX Low-Latency Mode .....	29
<b>5.6Trigger Timing Parameters.....</b>	<b>29</b>
5.6.1Trigger Delay .....	29
5.6.2Trigger Debounce Time .....	30
5.6.3Trigger Mask Time .....	30
5.6.4Trigger Noise Suppression Time .....	30
<b>5.7Digital I/O.....</b>	<b>31</b>
5.7.1General Purpose Input .....	31
5.7.2General Purpose Output .....	31
<b>5.8Strobe.....</b>	<b>31</b>
5.8.1Strobe Enable .....	31
5.8.2Strobe Polarity .....	32
5.8.3Strobe Operation .....	32
5.8.4Strobe Duration .....	32
5.8.5Strobe Delay .....	33
<b>5.9White Balance.....</b>	<b>33</b>
5.9.1Auto White Balance .....	33
5.9.2White Balance Mode .....	34
5.9.3Manual White Balance .....	35
<b>5.10Image Processing.....</b>	<b>37</b>
5.10.1Gamma .....	37
5.10.2Lookup Table .....	37
<b>5.11Color Processing.....</b>	<b>38</b>
5.11.1Hue .....	38
5.11.2Saturation .....	38
5.11.3Color Correction Matrix .....	39
<b>5.12Region of Interest for Auto Functions.....</b>	<b>41</b>
5.12.1Auto Functions ROI Enable .....	41
5.12.2Auto Functions ROI Preset .....	42
5.12.3Auto Functions ROI Custom Rectangle .....	42
<b>5.13User Sets.....</b>	<b>43</b>
5.13.1User Set Selector .....	43
5.13.2Load User Set .....	43

# Table of Contents

5.13.3	Save User Set .....	44
5.13.4	Default User Set .....	44
<b>5.14</b>	<b>Precision Time Protocol.....</b>	<b>44</b>
5.14.1	PTP Enable .....	44
5.14.2	PTP Status .....	45
<b>5.15</b>	<b>Action Scheduler.....</b>	<b>45</b>
5.15.1	Action Selector .....	45
5.15.2	Action Scheduler Time .....	45
5.15.3	Action Scheduler Interval .....	46
5.15.4	Action Scheduler Commit .....	46
5.15.5	Action Scheduler Cancel .....	46
<b>6.</b>	<b>Zoom Lens Information</b>	<b>48</b>
6.1	Minimum Object Distance.....	48
6.2	Zoom Factor.....	49
<b>7.</b>	<b>Revision History</b>	<b>50</b>

## 1 Quick Facts

General	
Vision Standard	GigE Vision
Dynamic Range	12 bit
Resolution	2048x1536
Frame Rate at Full Resolution	36
Pixel Formats	8-Bit Bayer (RG) 12-Bit Bayer Packed (RG) 16-Bit Bayer (RG) YUV 4:2:2 YUV 4:1:1 RGB24

Optical Interface	
IR-Cut filter	Yes (removable)
Sensor Type	Sony IMX265LQR-C
Shutter Type	Global
Sensor Format	1/1.8 inch
Pixel Size	3.45 $\mu\text{m}$

Integrated Lens	
Focal Length	6.8 mm (wide) to 136 mm (tele)
Minimal Object Distance	1 cm (wide) to 90 cm (tele)
Iris	F1.5 (wide) to F3.4 (tele)

Electrical	
Interface	GigE
Supply voltage	9 VDC to 27 VDC or POE: 48 VDC to 56 VDC
Current consumption	approx 400 mA @ 12 VDC
I/O Connector	6-pin connector for power supply, trigger and strobe or general purpose input/output

# Quick Facts

<b>Mechanical Data</b>	
Dimensions	H: 71 mm, W: 71 mm, L: 147
Mass	691 g

<b>Adjustments</b>	
Settling time	20 $\mu$ s to 30 s
Gain	0 dB to 48 dB

  

<b>Environmental Conditions</b>	
Housing Temperature (operating)	-5 °C to 45 °C
Temperature (storage)	-20 °C to 60 °C
Humidity (operating)	20 % to 80 % (non-condensing)
Humidity (storage)	20 % to 95 % (non-condensing)

# Dimensional Diagrams

## 2 Dimensional Diagrams

### 2.1 DFK 39GX265-Z20 Zoom Camera with Tripod Adapter

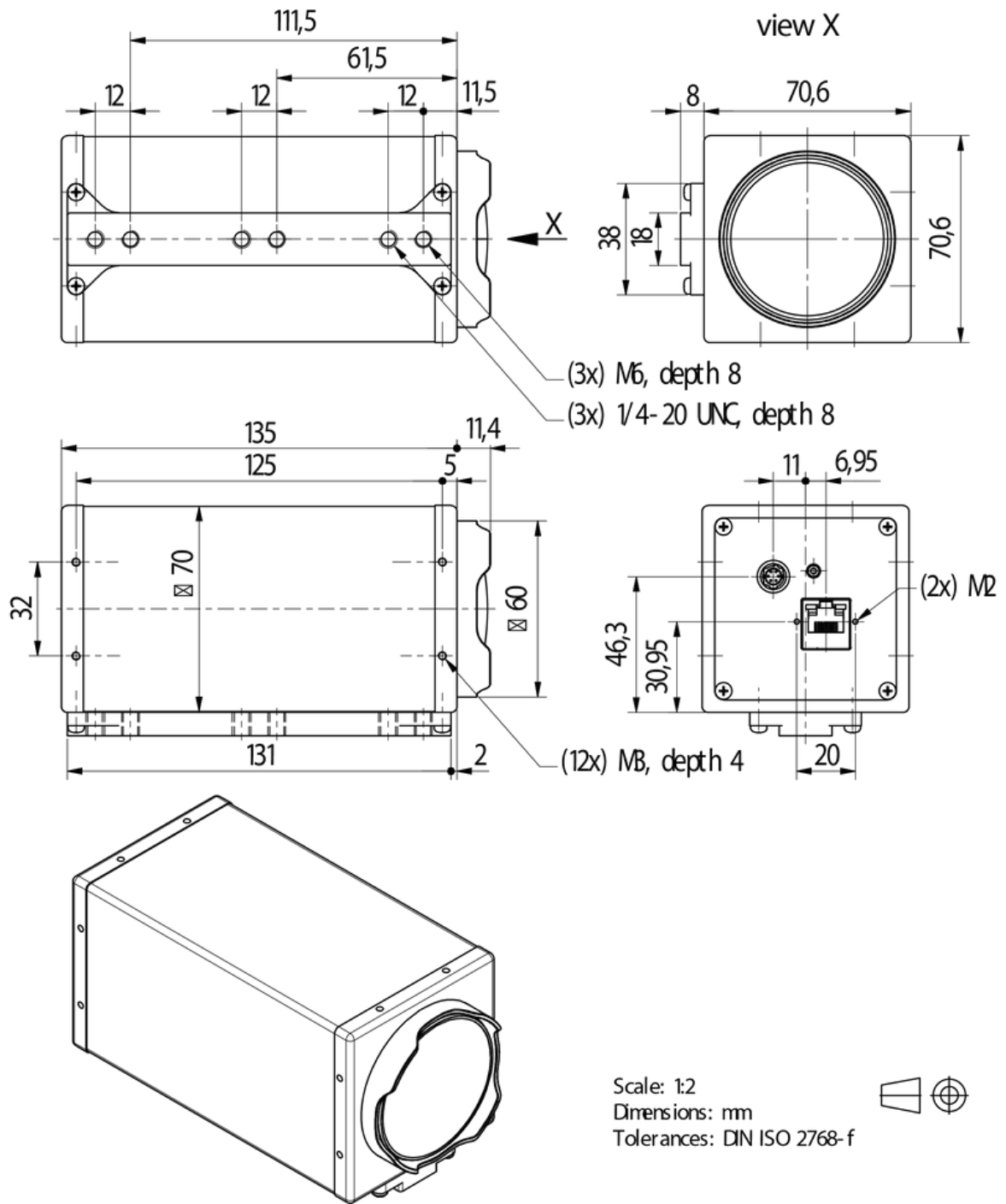

## 2.2 DFK 39GX265-Z20 Zoom Camera without Tripod Adapter

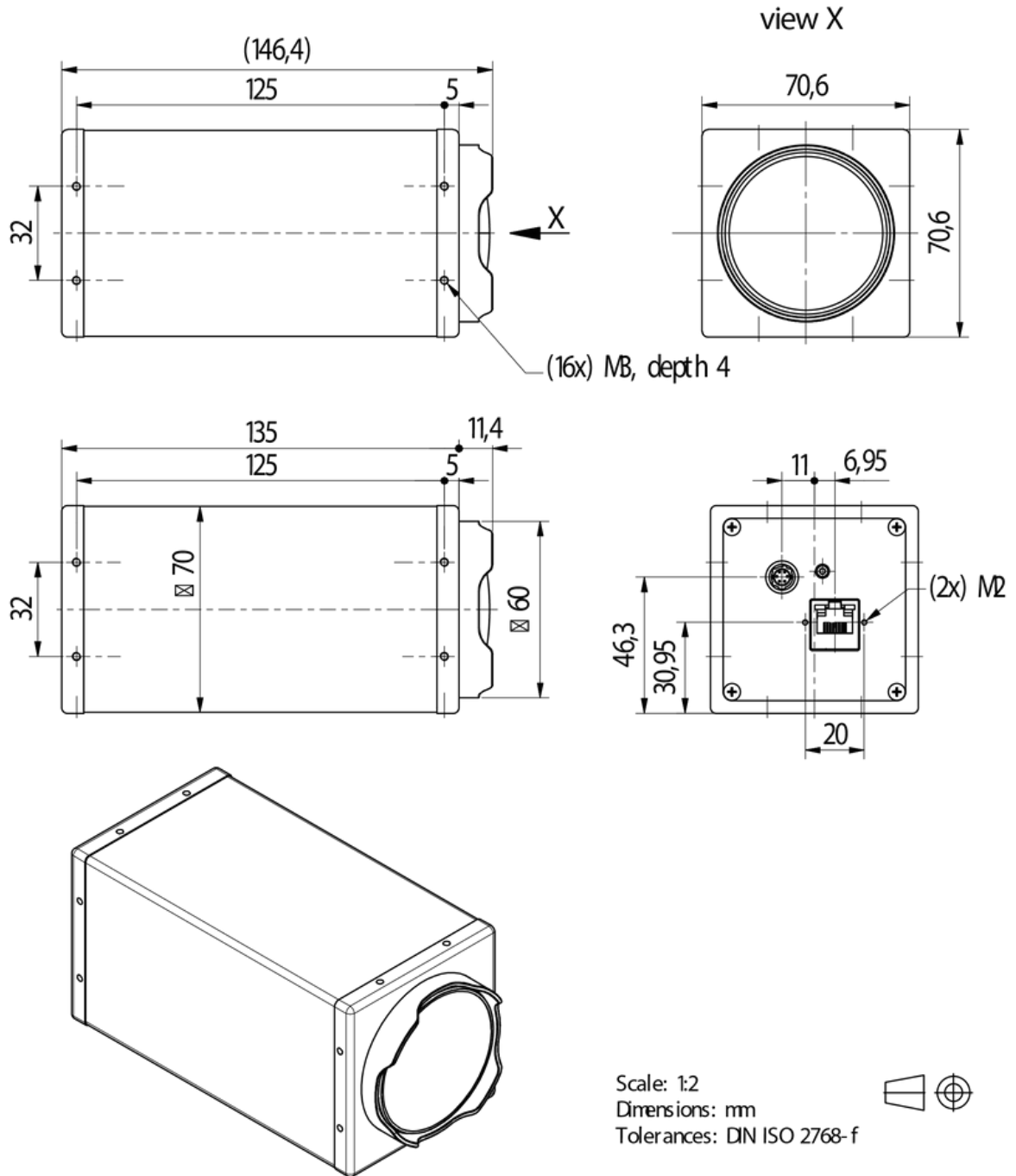



## 3 I/O Connector

### 3.1 6-pin I/O Connector

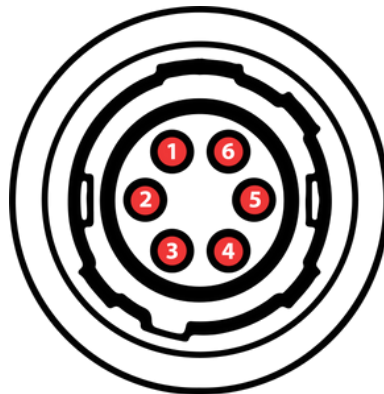

Rear view of camera

Pin	Signal	I/O	Remarks	Characteristics			Unit
				Min	Typ	Max	
1	GigE Power Supply	P <sup>3</sup>		9.0	12.0	27.0	V
2	TRIGGER_IN (+)	I3	Optocoupler signal	3.3	-	24.02	V
3	TRIGGER_IN (-)	I3	Optocoupler ground	2	-	-	-
4	STROBE_OUTPUT	O3	Open drain	-	-	24.01	V
5	GND_I/O	G3	External Ground (Open Drain)	-	-	-	-
6	GND_DC	G3	External Ground (Power Supply)	-	-	-	-

<sup>1</sup>max. 0.2A (ID) for open drain MOSFET!

<sup>2</sup>min. 3.5 mA driver strength required!

<sup>3</sup>G: Ground O: Output I: Input

The part number of this Hirose connector is HR10A-7R-6P(73). To create an I/O cable you need a Hirose connector HR10A-7P-6S(73).

#### 3.1.1 TRIGGER\_IN

The *TRIGGER\_IN* line can be used to synchronize the start of the exposure time with external events. The [Trigger](#) section describes in detail how the image sensor's behavior can be controlled.

The current input signal can also be read directly through the [General Purpose Input](#) feature.

## 3.1.2 STROBE\_OUT

The *STROBE\_OUT* line's main usage is to indicate the integration time of the image sensor which allows flashes, strobos or other light sources to be synchronized with camera operation. The line's behavior can be controlled through the [Strobe](#) controls.

The output signal can also be directly controlled through the [General Purpose Output](#) feature.

## 4 Spectral Characteristics

### 4.1 Spectral Sensitivity - IMX265LQR-C

Sensor: Sony IMX250/252/264/265 - courtesy of Sony Deutschland GmbH

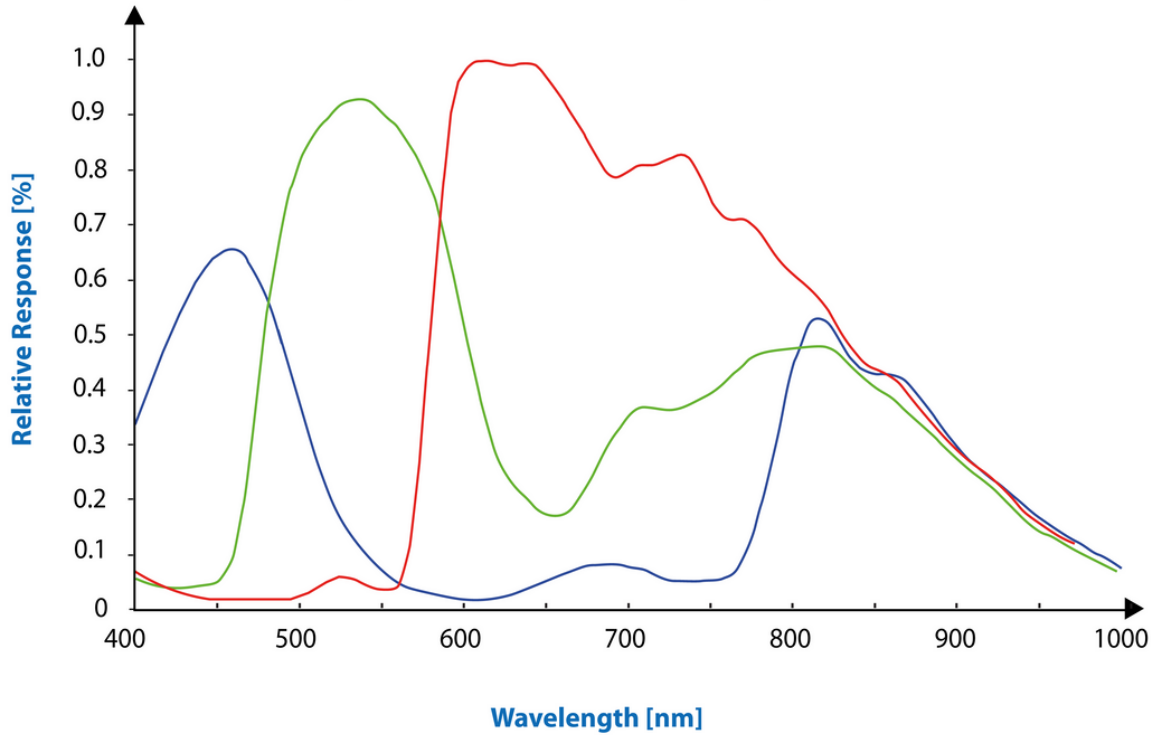

## 5 Camera Controls

This section describes the parameters available for the DFK 39GX265-Z20 camera.

The actual name of the parameter depends on the driver technology used to access the camera. Parameter names are listed for the most common ways to access the cameras:

*GigE Vision* (cross platform, via 3rd party driver)

· *IC Imaging Control* (on Windows, via *Device Driver for The Imaging Source GigE Cameras*)

### 5.1 Sensor Readout Control

#### 5.1.1 Pixel Format

The pixel format defines the data type of the pixels transmitted to the computer. The bits per pixel needed for a particular pixel format influence the required bandwidth.

The driver technology used to access the camera significantly impacts the way the pixel format is controlled:

·When using *GigE Vision*, the pixel format is controlled through the PixelFormat *GenICam* feature.

·When using *IC Imaging Control*, the pixel format is part of the video format - a parameter which combines pixel format, resolution and readout mode. For more information, refer to the *IC Imaging Control* documentation sections on VideoFormat and VideoFormatDesc.

The DFK 39GX265-Z20 color camera supports multiple pixel formats with variable bits-per-pixel settings. The names of the pixel formats and the way to select them depends on the driver used to control the camera. The following table contains a short overview of all possible formats followed by a more detailed description.

Pixel Format	Bits Per Pixel	GigE Vision	TIS GigE Driver
8-Bit Bayer (RG)	8	BayerRG8	RGB32
12-Bit Packed Bayer (RG)	12	BayerRG12p	Y800 RGB64, Y16
16-Bit Bayer (RG)	1	BayerRG16 RGB64Y16	,
YUV 4:2:2	6	YUV422_8 YUY2	
YUV 4:1:1 (a)	1	YCbCr411_8	
YUV 4:1:1 (b)	6	YCbCr411_8_CbYYCrYY Y411	
R GB2 4	1	BGR8 RGB24	

2

##### 5.1.1.1 8-Bit Bayer Raw

This format transmits data using one byte for each pixel.

2

4

*GigE Vision* drivers see this pixel format as one of the 8-bit bayer raw formats ( BayerGR8, BayerRG8, BayerGB8, BayerBG8).

The *Device Driver for The Imaging Source GigE Cameras* simplifies this variety of possible pixel formats and offers two video formats instead: RGB32 and Y800. The RGB32 format results from the driver's automatic debayering of the raw image data, while the Y800 format contains the raw data which is reinterpreted as monochrome.

## 5.1.1.2 12-Bit Packed Bayer Raw

This format transmits data using 3 bytes for each pair of 2 consecutive pixels.

*GigE Vision* drivers see this pixel format as one of the 12-bit packed bayer raw formats (BayerGR12Packed, BayerRG12Packed, BayerGB12Packed, BayerBG12Packed).

The *Device Driver for The Imaging Source GigE Cameras* simplifies this variety of possible pixel formats and offers two video formats instead: RGB64 and Y16. The RGB64 format results from the driver's automatic debayering of the raw image data, while the Y16 format contains the raw data which is reinterpreted as monochrome. Since the DFK 39GX265-Z20 camera offers both 12-bit packed and 16-bit bayer raw pixel formats, the driver uses the 12-bit packed format when the or video format is selected.

RGB64 Y16

## 5.1.1.3 16-Bit Bayer Raw

This format transmits data using 2 bytes for each pixel.

The sensor of the DFK 39GX265-Z20 camera is not able to provide 16-bit data output. The pixel data is transmitted in the most significant bits. This allows application programs to ignore the sensor-specific data type and to treat the data as if the sensor outputs 16 bits.

*GigE Vision* drivers see this pixel format as one of the 16-bit packed bayer raw formats (BayerGR16, BayerRG16, BayerGB16, BayerBG16).

The *Device Driver for The Imaging Source GigE Cameras* simplifies this variety of possible pixel formats and offers two video formats instead: RGB64 and Y16. The RGB64 format results from the driver's automatic debayering the raw image data, while the Y16 format contains the raw data which is reinterpreted as monochrome.

## 5.1.1.4 YUV 4:2:2

This format transmits an 8-bit luminance value for every pixel and a pair of chrominance values for every two pixels.

The camera converts the raw pixel data from the sensor to YUV 4:2:2. Since YUV 4:2:2 averages to 2 bytes per pixel, the YUV 4:2:2 pixel format requires two times the bandwidth of the 8-bit raw format, thus reducing the maximum possible frame rate.

*GigE Vision* drivers see this pixel format as YUV422\_8.

The *Device Driver for The Imaging Source GigE Cameras* offers this pixel format as the YUY2 video format.

## 5.1.1.5 YUV 4:1:1

This format transmits an 8-bit luminance value for every pixel and a pair of chrominance values for every four pixels.

The two YUV 4:1:1 pixel formats only differ in their byte order.

The camera converts the raw pixel data from the sensor to YUV 4:2:2. Since YUV 4:2:2 averages to 1.5 bytes per pixel, the YUV 4:1:1 pixel format requires two 50% more bandwidth than the 8-bit raw format, thus reducing the maximum possible frame rate.

*GigE Vision* drivers see this pixel format as

YCbCr411\_8\_CbYYCrYY  
YCbCr411\_8 and .

The *Device Driver for The Imaging Source GigE Cameras* offers this pixel format as the <sup>Y411</sup> video format.

## 5.1.1.6 RGB24

The camera converts the raw pixel data from the sensor to RGB24. Since RGB24 uses 3 bytes to store 1 pixel, the RGB24 pixel format requires three times the bandwidth of the 8-bit raw format, thus reducing the maximum possible frame rate.

*GigE Vision* drivers enumerate this pixel format as

BGR8.

The *Device Driver for The Imaging Source GigE Cameras* enumerates this pixel format as the <sup>RGB24</sup> video format.

## 5.1.2 Resolution

The DFK 39GX265-Z20 allows the user to specify which rectangular region of the image sensor to read out during camera operation. The size of this rectangle determines the number of pixels that have to be transferred for each frame and has a significant influence on the required network bandwidth.

Lowering the resolution also often allows the image sensor to operate at a higher frame rate. Changes in the vertical resolution have more effect on the maximum frame rate than changes in the horizontal direction.

The way the resolution is controlled varies greatly between the driver technology used to access the camera:

- When using *GigE Vision*, the resolution is controlled through the GenICam features Width and Height.

- When using *IC Imaging Control*, the resolution is part of the video format, a parameter that combines pixel format, resolution and readout mode. For more information, refer to the *IC Imaging Control* documentation sections on VideoFormat and

- VideoFormatDesc

Parameter	Horizontal Resolution
Minimum	528
Maximum	2048
GigE Vision: GenICam	Width

Parameter	Vertical Resolution
Minimum	4
Maximum	1536
GigE Vision: GenICam	Height

### 5.1.3 Readout Modes

The DFK 39GX265-Z20 camera offers different sensor readout modes.

By default, the camera outputs all pixels of the image sensor.

In *skipping* modes, the image sensor regularly skips a number of rows and/or columns during readout. The resulting output image is smaller but contains the same field of view than the image produced by default readout mode.

In *binning* modes, a number of neighboring pixels is merged into one output pixel during readout. The nature of this merge operation is sensor-specific, most sensors either add the pixel values or average them.

Generally, binning modes provide better image quality than skipping modes. However, skipping modes usually provide a higher maximum frame rate.

The way the readout modes are controlled depends greatly upon which driver technology is used to access the camera:

- When using GigE Vision, the readout mode is controlled through the *GenICam* features DecimationHorizontal, DecimationVertical, BinningHorizontal and BinningVertical.

- When using *IC Imaging Control*, the readout mode is part of the video format - a parameter that which combines pixel format, resolution and readout mode. For more information, refer to the *IC Imaging Control* documentation sections on VideoFormat and VideoFormatDesc.

The following readout modes are supported:

- Default
- Skipping 2X
- .

### 5.1.4 Frame Rate

The frame rate is specified in frames per second and determines the camera's operating speed.

# Camera Controls

The way the frame rate is controlled depends greatly upon which driver technology is used to access the camera:

- When using *GigEVision*, the frame rate is controlled through the *GenICam* feature `AcquisitionFrameRate`.

- When using IC Imaging Control, the frame rate is selected from a list of available frame rates through APIs such as `Grabber::setFPS` or `ICImagingControl.DeviceFrameRate`.

The range of available frame rates depends upon other camera settings such as well, pixel format, resolution and readout modes.

Parameter	Frame Rate
Minimum	Depending on Pixel Format, Resolution, and Readout Mode
Maximum	Depending on Pixel Format, Resolution, and Readout Mode
GigE Vision: GenICam	<code>AcquisitionFrameRate</code>

The following tables show the maximum frame rate for some combinations of pixel format and resolution.

## 8-Bit Bayer Raw

Width	Height	Maximum Frame Rate
2048	1536	36
1920	1080	54
640	480	366

## 12-Bit Packed Bayer Raw

Width	Height	Maximum Frame Rate
2048	1536	24
1920	1080	36
640	480	245

## 16-Bit Bayer Raw

Width	Height	Maximum Frame Rate
2048	1536	18
1920	1080	27
640	480	184



## YUV 4:2:2

Width	Height	Maximum Frame Rate
2048	1536	18
1920	1080	27
640	480	184

## YUV 4:1:1 (a)

Width	Height	Maximum Frame Rate
2048	1536	24
1920	1080	36
640	480	245

## YUV 4:1:1 (b)

Width	Height	Maximum Frame Rate
2048	1536	24
1920	1080	36
640	480	245

## RGB24

Width	Height	Maximum Frame Rate
2048	1536	12
1920	1080	18
640	480	122

### 5.1.5 Partial Scan Offset

If the selected resolution is smaller than the sensor size, the part of the sensor that is actually read out can be specified by the *Partial Scan Offset X* and *Partial Scan Offset Y* parameters. By default, the camera automatically positions the offsets so that the center of the sensor is used.

Parameter	Partial Scan Offset X
Minimum	0
Maximum	1520
GigE Vision: GenICam	OffsetX
VCD Property	VCDID_PartialScanOffset \VCDElement_PartialScanOffsetX

Parameter	Partial Scan Offset Y
Minimum	0
Maximum	1532
GigE Vision: GenICam	OffsetY
VCD Property	VCDID_PartialScanOffset \VCDElement_PartialScanOffsetY

If *Partial Scan Offset X* or *Partial Scan Offset Y* is configured to a value that would be invalid with the current setting of [Resolution](#) setting, the camera uses the maximum possible value.

Parameter	Partial Scan Auto Center
On	Automatically configure Partial Scan Offset X/Y so that the center area of the sensor is read out
True	
Off	Control Partial Scan Offset X/Y manually
False	
GigE Vision: GenICam	OffsetAutoCenter
VCD Property	VCDID_PartialScanOffset \VCDElement_PartialScanAutoCenter

## 5.1.6 Image Flipping

The DFK 39GX265-Z20 camera allows flipping of the image data horizontally, vertically, or both. The *Flip Horizontal* and *Flip Vertical* parameters can be used to control this sensor feature.

Parameter	Flip Horizontal
True	Image data is flipped horizontally
False	Image data is not flipped horizontally
GigE Vision: GenICam	ReverseX
VCD Property	VCDID_FlipHorizontal\VCDElement_Value

Parameter	Flip Vertical
True	Image data is flipped vertically
False	Image data is not flipped vertically
GigE Vision: GenICam	ReverseY
VCD Property	VCDID_FlipVertical\VCDElement_Value

## 5.2 Image Sensor Control

### 5.2.1 Exposure Time

The *Exposure Time* parameter defines the time the camera opens its (electronic) shutter when it is taking an image.

Parameter	Exposure Time
Minimum	20 $\mu$ s
Maximum	30 s
Default	auto
GigE Vision: GenICam	ExposureTime
VCD Property	VCDID_Exposure\VCDElement_Value

### 5.2.2 Gain

The *Gain* parameter defines the amplification that is applied to the image at sensor level.

Parameter	Gain
Minimum	0 dB
Maximum	48 dB
Default	auto
GigE Vision: GenICam	Gain
VCD Property	VCDID_Gain\VCDElement_Value

### 5.2.3 Black Level

The *Black Level* parameter defines the lowest possible intensity value of the image sensor.

Parameter	Black Level
Minimum	0
Maximum	4095
Default	240
GigE Vision: GenICam	BlackLevel
VCD Property	VCDID_Brightness\VCDElement_Value

## 5.3 Automatic Exposure and Gain Control

The DFK 39GX265-Z20 camera can automatically control gain and exposure time. These automatic functions are enabled by default.

In order to optimize image parameters, a region of interest can be specified for automatic functions. Specifying a region of interest enables fine-grained control over the image area for which the image parameters are optimized. A selection of pre-defined area presets is available, but the user can also specify the coordinates of a custom rectangle.

In certain situations, it is desirable to limit the range of the auto-controlled parameters. For example, one might want to avoid high gain settings in order to keep noise levels low. Other applications require limiting the maximum exposure time so that movements do not get blurred. Therefore, the ranges of the gain and exposure parameter can be limited. If both auto exposure and auto gain are active, the camera tries to lower the gain value in order to reduce noise and improve the image quality.

### 5.3.1 Auto Exposure

Parameter	Auto Exposure
Continuous	Enable Auto Exposure
True	
Off	Disable Auto Exposure
False	
GigE Vision: GenICam	ExposureAuto
VCD Property	VCDID_Exposure\VCDElement_Auto

## 5.3.2 Auto Gain

Parameter	Auto Gain
Continuous	Enable Auto Gain
True	
Off	Disable Auto Gain
False	
GigE Vision: GenICam	GainAuto
VCD Property	VCDID_Gain\VCDElement_Auto

## 5.3.3 Auto Reference Value

The *Auto Reference Value* parameter specifies the target brightness for both auto exposure and auto gain.

Parameter	Auto Reference Value
Minimum	0
Maximum	255
Default	128
GigE Vision: GenICam	ExposureAutoReference
VCD Property	VCDID_Exposure\VCDElement_AutoReference

## 5.3.4 Highlight Reduction

Enabling *Highlight Reduction* lets the auto exposure and auto gain functions reduce overexposed areas in the output image. This feature is particularly useful when using 10/12/16-bit output images and a tone mapping algorithm in post-processing when using higher bit depths as the dark areas still contain a lot of useful information.

Parameter	Highlight Reduction
True	Try to reduce overexposed areas
False	Ignore overexposed areas and focus on matching the image brightness to the selected <a href="#">Auto Reference Value</a> .
GigE Vision: GenICam	ExposureAutoHighlightReduction
VCD Property	VCDID_HighlightReduction\VCDElement_Value

## 5.3.5 Auto Exposure Limits

The *Auto Exposure Lower Limit* parameter determines the minimum possible value that can be set by the auto exposure algorithm.

Parameter	Auto Exposure Lower Limit
Minimum	20 $\mu$ s
Maximum	30 s
GigE Vision: GenICam	ExposureAutoLowerLimit

The *Auto Exposure Upper Limit* parameter determines the maximum possible value that can be set by the auto exposure algorithm.

Parameter	Auto Exposure Upper Limit
Minimum	20 $\mu$ s
Maximum	30 s
GigE Vision: GenICam	ExposureAutoUpperLimit
VCD Property	VCDID_Exposure\VCDElement_AutoMaxValue

If the *Auto Exposure Upper Limit Auto* parameter is enabled, the value of *Auto Exposure Upper Limit* is automatically kept at the maximum possible value for the current frame rate.

Parameter	Auto Exposure Upper Limit Auto
On	Select <i>Auto Exposure Upper Limit</i>
Off	automatically Let the user control <i>Auto</i>
GigE Vision: GenICam	ExposureUpperLimitAuto
VCD Property	VCDID_Exposure\VCDElement_AutoMaxValueAuto

## 5.3.6 Auto Gain Limits

The *Auto Gain Lower Limit* parameter determines the minimum possible value that can be set by the auto gain algorithm.

Parameter	Auto Gain Lower Limit
Minimum	0 dB
Maximum	48 dB
GigE Vision: GenICam	GainAutoLowerLimit

The *Auto Gain Upper Limit* parameter determines the maximum possible value that can be set by the auto gain algorithm.

Parameter	Auto Gain Upper Limit
Minimum	0 dB
Maximum	48 dB
GigE Vision: GenICam	GainAutoUpperLimit

## 5.4 Lens Control

The DFK 39GX265-Z20 zoom camera features a lens with motorized zoom and focus control. Additionally, the IR cut filter can also be easily snapped in and out of place via the camera software.

### 5.4.1 Zoom

The *Zoom* parameter controls the zoom motor's movement of the motorized lens.

The zoom motor can be used to change the lens's focal length which in turn will change its magnification factor and field of view.

Parameter	Zoom
Minimum	0
Maximum	1000
Default	0
GigE Vision: GenICam	Zoom
VCD Property	VCDID_Zoom\VCDElement_Value

### 5.4.2 Focus

The *Focus* parameter controls the movement of the focus motor in the motorized lens.

The focus motor can be used to change the focal plane, allowing the camera to resolve at other distances.

While the values of the *Focus* parameter are raw numbers, they correspond to distances: Low focus values map to shorter distances; high focus values map to longer distances.

Parameter	Focus
Minimum	0
Maximum	10000
Default	10000
GigE Vision: GenICam	Focus
VCD Property	VCDID_Focus\VCDElement_Value

**Important:** Because depth of field decreases with increasing focal length (i.e. zoom value), bear in mind that an in-focus image will not remain sharp when zooming in. Therefore, adjustments to the focus values will usually need to be made if the Zoom parameters have been changed.

### 5.4.3 Iris

The *Iris* parameter controls the opening of the lens iris.

Low values correspond to a closed iris, while the maximum value opens the iris as far as possible.

Parameter	Iris
Minimum	0
Maximum	255
Default	255
GigE Vision: GenICam	Iris
VCD Property	VCDID_Iris\VCDElement_Value

**Important:** The exact opening of the iris for a given *Iris* value differs from camera to camera. This implies that the minimum value for which the iris is not entirely closed may also differ.

### 5.4.4 Infrared Cut Filter

The *Infrared Cut Filter* parameter enables or disables the infrared cut filter of the lens.



Parameter	Infrared Cut Filter
true	The IR cut filter is enabled.
false	The IR cut filter is disabled.
GigE Vision: GenICam	IRCutFilterEnable
VCD Property	VCDID_IRCutFilter\VCDElement_Value

**Important:** Modern CMOS color sensors are very sensitive to infrared light. In order to achieve expected results, it is recommended that the infrared cut filter remain enabled when using a color camera.

## 5.4.5 Auto Focus

The *Auto Focus* function allows the camera to automatically adjust the lens to create a focused image.

The auto focus algorithm works by finding the maximum contrast of neighbouring pixel areas.

Parameter	Auto Focus
Execute	Run the auto focus algorithm
GigE Vision: GenICam	FocusAuto
VCD Property	VCDID_Focus\VCDElement_OnePush

## 5.4.6 Auto Focus ROI

The camera's auto focus algorithm can be instructed to only analyze a part of the image. If *Auto Focus ROI Enable* is set, only the pixels inside the rectangle specified by *Auto Focus ROI Left*, *Auto Focus ROI Top*, *Auto Focus ROI Width* and *Auto Focus ROI Height* will be used.

The rectangle is specified in absolute sensor coordinates; if the specified rectangle would be outside the currently active partial scan area, the camera automatically adjusts the size or position to form a valid rectangle.

Parameter	Auto Focus ROI Enable
true	Let auto focus only look at the specified rectangle
false	Let auto focus analyze the whole image
GigE Vision: GenICam	AutoFocusROIEnable
VCD Property	VCDID_Focus\VCDElement_AutoFocusROIEnable

Parameter	Auto Focus ROI Left
Minimum	0
Maximum	1920
GigE Vision: GenICam	AutoFocusROILeft
VCD Property	VCDID_Focus\VCDElement_AutoROILeft

Parameter	Auto Focus ROI Top
Minimum	0
Maximum	1520
GigE Vision: GenICam	AutoFocusROITop
VCD Property	VCDID_Focus\VCDElement_AutoROITop

Parameter	Auto Focus ROI Width
Minimum	128
Maximum	2048
GigE Vision: GenICam	AutoFocusROIWidth

Parameter	Auto Focus ROI Height
Minimum	16
Maximum	1536
GigE Vision: GenICam	AutoFocusROIHeight

## 5.4.7 Auto Iris

The *Auto Iris* parameter enables or disables the automatic control of the iris.

Used in conjunction with the features of [Automatic Exposure and Gain Control](#), Auto Iris is adjusted between exposure and gain, meaning that the iris will be opened before gain is increased.

Parameter	Auto Iris
true	Enable Auto Iris control
false	Disable Auto Iris control
GigE Vision: GenICam	IrisAuto
VCD Property	VCDID_Iris\VCDElement_Auto

## 5.5 Trigger

The trigger mode can be used to take images at very specific points in time which are specified by an electrical signal connected to the [TRIGGER\\_IN](#) pin of the I/O connector of the camera.

### 5.5.1 Trigger Mode

The *Trigger Mode* parameter enables the trigger mode.

Parameter	Trigger Mode
On	Enable Trigger Mode
True	
Off	Disable Trigger Mode
False	
GigE Vision: GenICam	TriggerMode
VCD Property	VCDID_Trigger\VCDElement_Value

### 5.5.2 Trigger Polarity

The *Trigger Polarity* parameter controls whether a trigger event is accepted on the rising or falling edge of the signal connected to the TRIGGER\_IN line.

Parameter	Trigger Polarity
RisingEdge	Accept rising edge as trigger signal
True	
FallingEdge	Accept falling edge as trigger signal
False	
GigE Vision: GenICam	TriggerActivation
VCD Property	VCDID_Trigger\VCDElement_Polarity

### 5.5.3 Software Trigger

The *Software Trigger* function can be used to simulate a trigger pulse, in turn causing one image to be exposed and delivered to the host computer.

Parameter	Software Trigger
Execute	Simulate one trigger pulse
GigE Vision: GenICam	TriggerSoftware
VCD Property	VCDID_Trigger\VCDElement_SoftwareTrigger

## 5.5.4 Trigger Burst Count

The *Trigger Burst Count* parameter allows the camera to be configured to take more than one image per trigger pulse. By default, this parameter is set to 1 so that exactly one image is acquired. The images are taken as rapidly as possible given current settings (i.e. as limited by the current exposure time and frame rate settings).

Parameter	Trigger Burst Count
Minimum	1
Maximum	1000
Default	1
GigE Vision: GenICam	AcquisitionBurstFrameCount
VCD Property	VCDID_Trigger\VCDElement_TriggerBurstCount

## 5.5.5 Trigger Source

The *Trigger Source* parameter allows the camera to be configured to only accept trigger signals from a specified source, e.g. only software trigger.

Parameter	Trigger Source
Any	Allow trigger signals from any source
Line1	Allow only hardware trigger
Software	Allow only software trigger
GigE Vision: GenICam	TriggerSource

## 5.5.6 Trigger Overlap

The *Trigger Overlap* feature gives information on when a new trigger pulse is accepted in the trigger -> exposure -> readout sequence.

Parameter	Trigger Overlap
Off	The next trigger pulse is only accepted once the previous frame has been read out from the sensor
Readout	The next trigger pulse is accepted during readout as long as the remaining readout time is shorter than the exposure time
GigE Vision: GenICam	TriggerOverlap
VCD Property	VCDID_Trigger\VCDElement_TriggerOverlap

## 5.5.7 IMX Low-Latency Mode

The *IMX Low-Latency Mode* parameter controls whether the sensor operates in low-latency trigger mode.

Parameter	IMX Low-Latency Mode
True	Delay between trigger input and start of exposure is exactly as configured through the <i>Trigger Delay</i> feature
False	Delay between trigger input and start of exposure is the time configured by the <i>Trigger Delay</i> feature in addition to a random delay depending on resolution, frame rate, and timing relative to the sensor's internal state
GigE Vision: GenICam	IMXLowLatencyTriggerMode
VCD Property	VCDID_Trigger\VCDElement_IMXLowLatencyMode

**Important:** If *IMX Low-Latency Mode* is enabled, *Trigger Overlap* is not allowed and is thereby forced to `Off`.

## 5.6 Trigger Timing Parameters

The 39G series camera series offers several options for dealing with bad trigger signals. By using the *Debounce Time*, *Denoise Time* and *Mask Time* parameters, the camera can be configured to ignore pulses on its [TRIGGER\\_IN](#) line under certain conditions.

Useful values for these parameters are application-specific. They depend on the expected trigger frequency, the exposure time and assumptions about the input signal quality. The default values for all these parameters is 0  $\mu$ s, assuming perfect signal quality.

### 5.6.1 Trigger Delay

The *Trigger Delay* parameter specifies a time for which the camera waits between receiving a trigger signal and starting the exposure of an image. Simulated trigger pulses generated through the *Software Trigger* function are not delayed by this parameter.

Parameter	Trigger Delay
Minimum	0 s
Maximum	1 s
Default	0 s
GigE Vision: GenICam	TriggerDelay
VCD Property	VCDID_Trigger\VCDElement_TriggerDelay

## 5.6.2 Trigger Debounce Time

The *Trigger Debounce Time* parameter specifies the time for which the trigger input has to be low in order for the next trigger signal to be accepted.

Parameter	Trigger Debounce Time
Minimum	0 s
Maximum	1 s
Default	0 s
GigE Vision:	TriggerDebouncer
GenICam VCD	VCDID_Trigger\VCDElement_TriggerDebouncer

Property

## 5.6.3 Trigger Mask Time

The *Trigger Mask Time* parameter specifies the time for which trigger pulses are ignored after accepting a trigger signal.

Parameter	Trigger Mask Time
Minimum	0 s
Maximum	1 s
Default	0 s
GigE Vision:	TriggerMask
GenICam VCD	VCDID_Trigger\VCDElement_TriggerMask

Property

## 5.6.4 Trigger Noise Suppression Time

The *Trigger Noise Suppression Time* parameter specifies the time for which trigger input has to be active in order to be accepted as a trigger signal.

Parameter	Trigger Noise Suppression Time
Minimum	0 s
Maximum	1 s
Default	0 s
GigE Vision:	TriggerDenoise
GenICam VCD	VCDID_Trigger\VCDElement_TriggerDenoise

Property

## 5.7 Digital I/O

The 39G series has one digital input and one digital output. The digital input can be used as a [Trigger](#) input but the current status can also be examined directly.

The digital output can be configured as a [Strobe](#) output to signal the exact moment when the image sensor is sensitive to light so that external light sources can be synchronized to its operation cycle.

### 5.7.1 General Purpose Input

The *General Purpose Input* parameter allows the current status of the [TRIGGER\\_IN](#) pin.

Parameter	General Purpose Input
True 1	TRIGGER_IN line status is low
False 0	TRIGGER_IN line status is high
GigE Vision:	GPIIn
GenICam VCD Property	VCDID_GPIO\VCDElement_GPIORead VCDID_GPIO\VCDElement_GPIOIn

### 5.7.2 General Purpose Output

The *General Purpose Output* parameter controls the status of the [STROBE\\_OUT](#) pin.

Parameter	General Purpose Output
True 1	Drive the STROBE_OUT line high
False 0	Drive the STROBE_OUT line low
GigE Vision:	GPOut
GenICam VCD Property	VCDID_GPIO\VCDElement_GPIOWrite VCDID_GPIO\VCDElement_GPIOOut

## 5.8 Strobe

The strobe function controls the automatic generation of output pulses on the [STROBE\\_OUT](#) pin which is synchronized to the image sensor's exposure time.

### 5.8.1 Strobe Enable

The *Strobe Enable* parameter enables the automatic generation of strobe pulses.

Parameter	Strobe Enable
On	Strobe
True	enabled
Off	Strobe disabled
False	
GigE Vision:	StrobeEnable
GenICam VCD	VCDID_Strobe\VCDElement_Value

Property

## 5.8.2 Strobe Polarity

The *Strobe Polarity* parameter can be used to invert the strobe pulse output.

Parameter	Strobe Polarity
ActiveHigh	The STROBE_OUT pin is logically high during the exposure time
True	
ActiveLow	The STROBE_OUT pin is logically low during the exposure time
False	
GigE Vision:	StrobePolarity
GenICam VCD	VCDID_Strobe\VCDElement_StrobePolarity

Property

## 5.8.3 Strobe Operation

The *Strobe Operation* parameter specifies how the length of the strobe pulses are controlled.

Parameter	Strobe Operation
Exposure	Output pulse duration is equal to the current exposure time
True	
FixedDuration	Output pulse duration is specified by <i>Strobe Duration</i>
False	
GigE Vision:	StrobeOperation
GenICam VCD	VCDID_Strobe\VCDElement_StrobeMode

Property

## 5.8.4 Strobe Duration

The *Strobe Duration* parameter controls the length of the strobe pulses if *Strobe Operation* is set to use the fixed duration mode.



Parameter	Strobe Duration
Minimum	0 $\mu$ s
Maximum	32767 $\mu$ s
GigE Vision:	StrobeDuration
GenICam VCD	VCDID_Strobe\VCDElement_StrobeDuration

Property

## 5.8.5 Strobe Delay

The *Strobe Delay* parameter can be used to add a small delay between the start of exposure and the strobe output pulse.

Parameter	Strobe Delay
Minimum	0 $\mu$ s
Maximum	32767 $\mu$ s
GigE Vision:	StrobeDelay
GenICam VCD	VCDID_Strobe\VCDElement_StrobeDelay

Property

## 5.9 White Balance

The DFK 39GX265-Z20 color camera can perform white balance by digital multiplication of the appropriate raw pixel values.

### 5.9.1 Auto White Balance

DFK 39GX265-Z20 can perform *Auto White Balance*. It can be enabled continuously when changes in lighting conditions are expected. Under controlled lighting conditions, however, one-time white balance calibration is the recommended approach.

To perform one-time white balance calibration, place a reference white sheet in front of

the

camera and set `BalanceWhiteAuto` to *Once*. The camera will then find the correct white balance settings for the current light conditions and keep them active until instructed otherwise.

Parameter	Auto White Balance
Continuous True	Enable automatic white balance
Once One Push	Enable automatic white balance until the color channels have been balanced once
Off	Disable automatic white balance
False	
GigE Vision:	BalanceWhiteAuto
GenICam VCD Property	VCDID_WhiteBalance\VCDElement_Auto VCDID_WhiteBalance\VCDElement_OnePush

## 5.9.2 White Balance Mode

The default auto white balance algorithm is *Gray World*. It is selected by setting the *White Balance Mode* accordingly. The *Gray World* algorithm operates under the assumption that the average color of a scene is near gray and adjusts the white balance coefficients so the average color of the resulting image is gray as well. In the case where this assumption is wrong (e.g. the camera is pointing at a blue carpet), the auto white balance algorithm will select coefficients that do not result in a visually accurate image.

To avoid the problems posed by the *Gray World* algorithm, the *Temperature* mode can be used. This mode operates by trying to determine the color temperature of the light source.

Parameter	White Balance Mode
Gray World	Use the <i>Gray World</i> model
Temperature	Use the <i>Temperature</i> model
GigE Vision:	BalanceWhiteMode
GenICam VCD Property	VCDID_WhiteBalance \VCDElement_WhiteBalanceMode

To assist the automatic white balance temperature detection, *White Balance Auto Preset* can be used to limit the range of valid color temperatures.

Parameter	White Balance Auto Preset
Any	Allow any color temperature
Auto Warm White	Limit color temperature to approximately 2500-4000 K
Auto Cool White	Limit color temperature to approximately 4000-5800 K
Auto Daylight	Limit color temperature to approximately 5700-7500 K
Auto Deep Shade	Limit color temperature to approximately 7500-10000 K
GigE Vision:	BalanceWhiteAutoPreset
GenICam VCD Property	VCDID_WhiteBalance \VCDElement_WhiteBalanceAutoPreset

### 5.9.3 Manual White Balance

If *Auto White Balance* is not enabled, the amplifiers for the red, green and blue channels can be controlled manually.

Parameter	White Balance Red
Minimum	0
Maximum	3.984375
Default	auto
GigE Vision:	BalanceRatio[BalanceRatioSelector=Red]
GenICam VCD Property	VCDID_WhiteBalance \VCDElement_WhiteBalanceRed

Parameter	White Balance Green
Minimum	0
Maximum	3.984375
Default	auto
GigE Vision:	BalanceRatio[BalanceRatioSelector=Green]
GenICam VCD Property	VCDID_WhiteBalance \VCDElement_WhiteBalanceGreen

# Camera Controls

Parameter	White Balance Blue
Minimum	0
Maximum	3.984375
Default	auto
GigE Vision:	BalanceRatio[BalanceRatioSelector=Blue]
GenICam VCD Property	VCDID_WhiteBalance \VCDElement_WhiteBalanceBlue

If *White Balance Mode* is set to *Temperature*, the color temperature can be set directly. Additionally, a light source can be selected from a list of presets.

Parameter	White Balance Temperature
Minimum	2500 K
Maximum	10000 K
Default	auto
GigE Vision:	BalanceWhiteTemperature
GenICam VCD Property	VCDID_WhiteBalance \VCDElement_WhiteBalanceTemperature

Parameter	White Balance Temperature Preset
Sodium-Vapor Lamp	2500 K
Warm Light	2700 K
Halogen Light	3000 K
Neutral White	3500 K
Cool White Fluorescent Light	4000 K
Cool White/Daylight (CFL)	5000 K
Daylight	6000 K
Cool White LED	7500 K
Blue Sky	10000 K
GigE Vision:	BalanceWhiteTemperaturePrese
GenICam VCD Property	t VCDID_WhiteBalance t \VCDElement_TemperaturePrese

## 5.10 Image Processing

### 5.10.1 Gamma

The 39G series cameras can perform gamma correction on the image data. If the pixel format of a color camera is set a YUV mode, gamma correction is applied to the Y channel. In bayer raw and RGB24 modes, all color channels are subject to the same gamma correction.

Parameter	Gamma
Minimum	0.01
Maximum	5.0
Default	5.0
GigE Vision:	Gamma
GenICam VCD	VCDID_Gamma\VCDElement_Value

Property

### 5.10.2 Lookup Table

The 39G series allows the user to specify a lookup table (LUT) that can transform pixel values. This lookup table can be used to perform tasks like histogram equalization inside the camera.

If the pixel format of a color camera is set to one of the YUV modes, the lookup table is applied only to the Y channel. In bayer raw and RGB24 modes, all color channels are subject to the same lookup operation.

The lookup table has 257 16-bit entries. The upper 8 bits of the image data are used to select the appropriate entry in the lookup table, while the remaining bits are used to interpolate between the selected entry and one of its neighbors.

The *LUT Enable* feature enables the lookup table.

Parameter	LUT Enable
True	Enable lookup table operation
False	Disable lookup table operation
GigE Vision: GenICam	LUTEnable

The lookup table values can be programmed using the *LUT Index* and *LUT Value* features.

Parameter	LUT Index
Minimum	0
Maximum	256
GigE Vision: GenICam	LUTIndex

Parameter	LUT Value
Minimum	0
Maximum	65535
GigE Vision: GenICam	LUTValue

The whole lookup table can be quickly reprogrammed through the *LUT Value All* feature.

Parameter	LUT Value All
Value	1028 bytes of memory containing 257 LUT entries. Each 16-bit LUT entry is aligned on a 32-bit boundary
GigE Vision: GenICam	LUTValueAll

**Important:** Since gamma correction is implemented using the same hardware as the lookup table, gamma correction is disabled when the lookup table is enabled.

## 5.11 Color Processing

The DFK 39GX265-Z20 color camera allows color adjustments with the *Hue* and *Saturation* parameters. These adjustments work with all output pixel formats.

**Important:** When a bayer raw pixel format is selected, *Hue* and *Saturation* still work. However, when at least one of them is enabled (set to non-default value), the resulting image is slightly blurred because of the way these parameters are implemented internally.

### 5.11.1 Hue

The *Hue* parameter controls the color angle of the output image.

Parameter	Hue
Minimum	-18
Maximum	0
Default	180
GigE Vision:	Hue
GenICam VCD	VCDID_Hue\VCDElement_Value

Property

### 5.11.2 Saturation

The *Saturation* parameter controls the color saturation of the output image.

Parameter	Saturation
Minimum	0
Maximum	255
Default	64
GigE Vision:	Saturation
GenICam VCD	VCDID_Saturation\VCDElement_Value

Property

### 5.11.3 Color Correction Matrix

As seen in the [Spectral Characteristics](#) diagram, the frequencies at which the red, green and blue pixels respond to incoming light overlap. This causes the colors of objects in captured images to differ from the colors of the same objects seen in reality.

A RGB to RGB color correction matrix can be used to change the pixel data output of the camera so that the colors in captured image are a closer match to what is expected by human observers.

Parameter	Enable Color Correction Matrix
True	Enable Color Correction Matrix
False	Disable Color Correction Matrix
GigE Vision:	ColorTransformationEnable
GenICam VCD	VCDID_ColorMatrix\VCDElement_Value

Property

By default, the values of the color matrix coefficients are initialized with values optimized for skin tones and other everyday objects.

If necessary, the matrix coefficients can be controlled manually.

When using *GenICam*, select a coefficient using `ColorTransformationValueSelector` and then change it via the `ColorTransformationValue`.

When using *IC Imaging Control*, the matrix coefficients are controlled via the elements of `VCDID_ColorMatrix[RGB][RGB]` `VCDID_ColorMatrix`

Parameter	Red contribution to the red pixel
Minimum	-1.0
Maximum	3.0
GigE Vision: GenICam	ColorTransformationValue [ColorTransformationValueSelector=Gain00]
VCD Property	VCDID_ColorMatrix \VCDElement_ColorMatrixRR

# Camera Controls

Parameter	Green contribution to the red pixel
Minimum	-1.0
Maximum	3.0
GigE Vision: GenICam	ColorTransformationValue [ColorTransformationValueSelector=Gain01]
VCD Property	VCDID_ColorMatrix \VCDElement_ColorMatrixRG

Parameter	Blue contribution to the red pixel
Minimum	-1.0
Maximum	3.0
GigE Vision: GenICam	ColorTransformationValue [ColorTransformationValueSelector=Gain02]
VCD Property	VCDID_ColorMatrix \VCDElement_ColorMatrixRB

Parameter	Red contribution to the green pixel
Minimum	-1.0
Maximum	3.0
GigE Vision: GenICam	ColorTransformationValue [ColorTransformationValueSelector=Gain10]
VCD Property	VCDID_ColorMatrix \VCDElement_ColorMatrixGR

Parameter	Green contribution to the green pixel
Minimum	-1.0
Maximum	3.0
GigE Vision: GenICam	ColorTransformationValue [ColorTransformationValueSelector=Gain11]
VCD Property	VCDID_ColorMatrix \VCDElement_ColorMatrixGG

Parameter	Blue contribution to the green pixel
Minimum	-1.0
Maximum	3.0
GigE Vision: GenICam	ColorTransformationValue [ColorTransformationValueSelector=Gain12]
VCD Property	VCDID_ColorMatrix \VCDElement_ColorMatrixGB



Parameter	Red contribution to the blue pixel
Minimum	-1.0
Maximum	3.0
GigE Vision: GenICam	ColorTransformationValue [ColorTransformationValueSelector=Gain20]
VCD Property	VCDID_ColorMatrix \VCDElement_ColorMatrixBR

Parameter	Green contribution to the blue pixel
Minimum	-1.0
Maximum	3.0
GigE Vision: GenICam	ColorTransformationValue [ColorTransformationValueSelector=Gain21]
VCD Property	VCDID_ColorMatrix \VCDElement_ColorMatrixBG

Parameter	Blue contribution to the blue pixel
Minimum	-1.0
Maximum	3.0
GigE Vision: GenICam	ColorTransformationValue [ColorTransformationValueSelector=Gain22]
VCD Property	VCDID_ColorMatrix \VCDElement_ColorMatrixBB

## 5.12 Region of Interest for Auto Functions

The 39G series cameras allow for the setting of a region of interest that is used while controlling the [Auto Exposure](#), [Auto Gain](#) and [Auto White Balance](#) functions.

### 5.12.1 Auto Functions ROI Enable

The *Auto Functions ROI Enable* parameter allows for the use of a region of interest for auto functions.

Parameter	Auto Functions ROI Enable
True	Auto functions only take a specified part of the image into account
False	Auto functions look at the whole image
GigE Vision:	AutoFunctionsROIEnable
GenICam VCD	VCDID_AutoRoi\VCDElement_Value

Property

## 5.12.2 Auto Functions ROI Preset

The *Auto Functions ROI Preset* parameter lets the user select from a list of ROI presets.

Parameter	Auto Functions ROI Preset
Full Sensor	Select the full output image
Center 50%	Select a rectangular area in the center of the output
Center 25%	image Select a small rectangular area in the center of the output
Bottom Half	image
Top Half	Select the bottom half of the output image
Custom Rectangle	Select the top half of the output image
GigE Vision:	Select a custom rectangle for fine-grained control AutoFunctionsROIPreSet
GenICam VCD	VCDID_AutoRoi\VCDElement_AutoRoiPreSet

Property

## 5.12.3 Auto Functions ROI Custom Rectangle

When *Auto Functions ROI Preset* is set to *Custom Rectangle*, the user can manually set the position and size of the region of interest. The coordinates are relative to the origin of the current video format as specified by [Partial Scan Offset](#).

Parameter	Auto Functions ROI Left
Minimum	0
Maximum	2032
GigE Vision:	AutoFunctionsROILeft
GenICam VCD	VCDID_AutoRoi \VCDElement_AutoRoiLeftRelative

Property

Parameter	Auto Functions ROI Top
Minimum	0
Maximum	1520
GigE Vision:	AutoFunctionsROITop
GenICam VCD	VCDID_AutoRoi \VCDElement_AutoRoiTopRelative

Property

Parameter	Auto Functions ROI Width
Minimum	16
Maximum	2048
GigE Vision:	AutoFunctionsROIWidth
GenICam VCD Property	VCDID_AutoRoi VCDElement_AutoRoiWidthRelative

Parameter	Auto Functions ROI Height
Minimum	16
Maximum	1536
GigE Vision:	AutoFunctionsROIHeight
GenICam VCD Property	VCDID_AutoRoi VCDElement_AutoRoiHeightRelative

## 5.13 User Sets

The 39G series cameras can store their complete configuration into built-in non-volatile memory. The camera configuration can be saved into and restored from one of two available memory slots upon user's request. Additionally, the camera can be configured to load one of the user's camera configurations at startup.

### 5.13.1 User Set Selector

The *User Set Selector* parameter selects the memory slot on which consecutive load and save commands are executed.

Parameter	User Set Selector
UserSet1	First of the two memory slots for user configurations
UserSet2	Second of the two memory slots for user configurations
Default	A special memory slot that always contains the camera's factory default configuration. It cannot be overwritten
GigE Vision: GenICam	UserSetSelector

### 5.13.2 Load User Set

By using the *Load User Set* command, the user can restore the camera configuration from the memory slot selected by *User Set Selector*.

Parameter	Load User Set
Execute	Restore the camera configuration from the memory slot specified by <i>User Set Selector</i>
GigE Vision: GenICam	UserSetLoad

### 5.13.3 Save User Set

By using the *Save User Set* command, the user can save the camera configuration into the memory slot selected by *User Set Selector*.

Parameter	Save User Set
Execute	Save the current camera configuration into the memory slot specified by <i>User Set Selector</i>
GigE Vision: GenICam	UserSetSave

### 5.13.4 Default User Set

The *Default User Set* parameter controls the camera's startup behavior. It selects which memory slot is used for device initialization when the camera is powered up.

Parameter	Default User Set
UserSet1	Load configuration from the first memory slot
UserSet2	Load configuration from the second memory slot
Default	Load factory default configuration
GigE Vision: GenICam	UserSetDefault

## 5.14 Precision Time Protocol

The 39G series can synchronize its internal clock to other devices via *Precision Time Protocol* (PTP, IEEE 1588).

When multiple PTP devices are connected through the same network, they will synchronize their clocks. This allows the image timestamps to remain comparable between cameras.

A camera running with PTP enabled can also schedule actions to be executed at a specified time point in the future through *Scheduled Actions*.

PTP is enabled by default.

### 5.14.1 PTP Enable

The *PTP Enable* parameter enables or disables the camera's usage of the *Precision Time Protocol*.

Parameter	PTP Enable
True	Use Precision Time
False	Protocol PTP disabled
GigE Vision: GenICam	PtpEnable

## 5.14.2 PTP Status

*PTP Status* is a read-only feature that reports the current status of the *Precision Time Protocol* algorithm.

Parameter	PTP Status
Master	The camera acts as PTP master clock.
Slave	The camera synchronizes its time stamp to a PTP master clock.
Uncalibrated	PTP was recently enabled, or a recent change in the network configuration initiated a resynchronization.
Disabled	PTP is disabled.
GigE Vision: GenICam	PtpStatus

## 5.15 Action Scheduler

When *Precision Time Protocol* is enabled, the action scheduler can be used to plan and run actions at some point in the future.

The only action the camera can perform right now is triggering images.

Action triggers are only accepted when [Trigger Source](#) is set to `Action0` or `Any`.

### 5.15.1 Action Selector

The *Action Selector* feature selects the action that the [Action Scheduler Time](#), [Action Scheduler Interval](#), [Action Scheduler Commit](#) and [Action Scheduler Cancel](#) features act on.

Parameter	Action Selector
0	<code>Action0</code> , which is hard-wired to trigger images
GigE Vision: GenICam	ActionSelector

### 5.15.2 Action Scheduler Time

The *Action Scheduler Time* is the time for when an action is scheduled, specified as a PTP timestamp in nanosecond units.

Scheduling the action to a time in the past will cause the action to be performed immediately.

Scheduling a repeated action to start in the past will ignore missed actions and continue as if it had been scheduled earlier.

Parameter	Action Scheduler Time
GigE Vision: GenICam	ActionSchedulerTime

### 5.15.3 Action Scheduler Interval

The *Action Scheduler Interval* feature allows instructing the action scheduler to repeat the scheduled action in a fixed interval, indefinitely.

If the interval is set to 0, the action is performed once and not repeated.

The interval is specified in microseconds.

Parameter	Action Scheduler Interval
Minimum	0
Maximum	4294967295 us
GigE Vision: GenICam	ActionSchedulerInterval

### 5.15.4 Action Scheduler Commit

Executing the *Action Scheduler Commit* command commits an action to the queue of scheduled actions.

The action is planned to be performed at the time specified by [Action Scheduler Time](#).

If [Action Scheduler Interval](#) has a value other than 0, the action will be repeated with the specified interval indefinitely, or until the [Action Scheduler Cancel](#) command is executed.

There is a finite number of queue slots available, trying to queue too many actions will fail.

The maximum length of the queue is reported by the [ActionQueueSize](#) feature.

Parameter	Action Scheduler Commit
Execute	Schedule the action specified by Action Selector to be performed at a specified time in the future.
GigE Vision: GenICam	ActionSchedulerCommit

### 5.15.5 Action Scheduler Cancel

Executing the *Action Scheduler Cancel* command cancels all scheduled actions of the action type selected by [Action Selector](#).

# Camera Controls

Parameter	Action Scheduler Cancel
Execute	Cancel all scheduled actions of the type specified by Action Selector.
GigE Vision: GenICam	ActionSchedulerCancel

## 6 Zoom Lens Information

### 6.1 Minimum Object Distance

The minimum object distance of the lens depends on the current Zoom setting. The following diagram approximates the relationship between the focal length (f) of the lens and the minimum object distance (MOD):

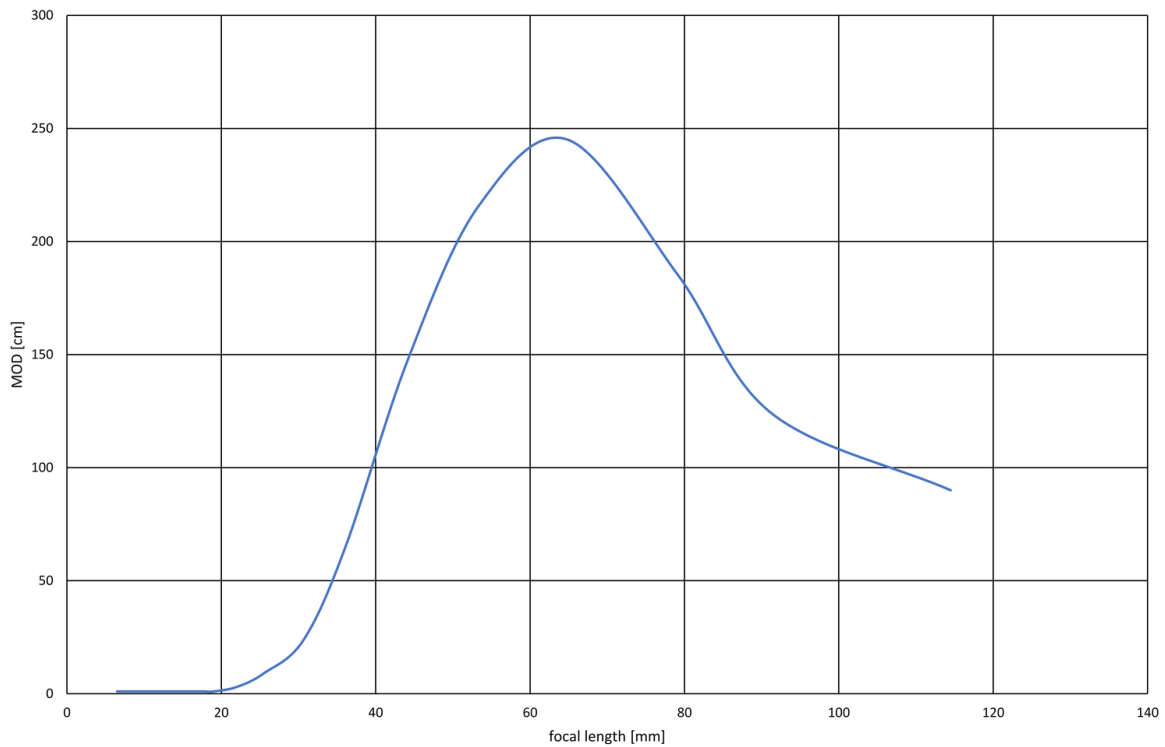



## 6.2 Zoom Factor

The following table shows the relation between the Zoom setting and the resulting focal length, measured at a distance of 2.5m:

Zoom	Focal Length [mm]
0	6.5
50	7.2
100	7.9
150	8.9
200	9.6
250	10.5
300	11.8
350	13.2
400	14.7
450	17.7
500	19
550	22
600	25.5
650	30.7
700	36.2
750	44.2
800	53.4
850	64.9
900	79.2
950	91.3
1000	114.5

## 7 Revision History

Date	Version	Description
2019/04/01		Initial release of this document
2020/03/05	Firmware 2494	Add IEEE1588 PTP support
2023/07/19		Update environmental section in quick facts chapter
2023/07/26	Firmware 2966	Add ChunkExposureTime, ChunkGain features
2023/07/26	Firmware 2966	Add EventExposureEnd, EventFrameTriggerMissed, EventLine1RisingEdge, EventLine1FallingEdge features