



Global Flex Mfg.

**Metal Hose &
Expansion Joint Tech**

Global  Flex Mfg.

METAL HOSE PRODUCT LINE

METAL HOSE PRODUCT LINE

SN SERIES

The standard of the industry when a Type 321 or 316 stainless steel hose is required, SN is constructed with a close-pitch “omega” design annular corrugation to provide a high degree of flexibility and long life, available in lengths up to fifty feet, depending on diameter.

BN SERIES

Designed specifically as flexible connections in bronze or copper lines, BN is built with bronze, butt-welded, close pitch corrugated hose, covered with bronze braid. Available in sized ¼ up to 4”

UN SERIES

UN is the most flexible metal hose available anywhere. The unique hydro-formed annular hose construction provides unequal ed cycle life. UN is the only ISO 10380 approved hose in the world – far surpassing international standards for cycle life and reliability. Available in Type 321 or 316 stainless steel.

UNHP SERIES

When a higher-pressure metal hose is required, UNHP will provide ultra high-pressure resistance and much better flexibility than other high-pressure hoses. UNHP is constructed with a Type 316 stainless steel, hydro-formed convoluted hose 321 & 316 stainless steel with series 300 stainless steel braids.

GF SERIES

The Global-Flex line of interlocked hose is available in most stainless steel alloys, aluminum, bronze, brass, aluminized, galvanized, and tin plate. Various packings are available to withstand high pressures and temperature extremes. A complete assortment of fittings, flanges, and couplers are also available.

STYLE SN DATA SHEET

MATERIAL:
Hose: 321 or 316 stainless steel

Braid: 300 series stainless steel

CONSTRUCTION:

Annular butt-welded, mechanically formed close pitch corrugated hose.

Pressure applications:

Full vacuum to working pressures listed below.

USN – UNBRAIDED HOSE

SN – SINGLE BRAIDED HOSE

DSN – DOUBLE BRAIDED HOSE

Nominal Diameter (Inches)	Actual ID (Inches)	Number of Braids	Nominal OD (Inches)	STATIC		DYNAMIC		Burst Pressure @ 70° F (PSIG)	Weight Per Foot (Pounds)
				Minimum Bend Radius (Inches)	Maximum Working Pressure @ 70° F (PSIG)	Minimum Bend Radius (Inches)	Maximum Working Pressure @ 70° F (PSIG)		
1/4"	.32	0	.46	4	140	6	140	9500	.9
		1	.51		2375		2375		.18
		2	.56		3125		3125		.27
3/8	.42	0	.61	2	100	4	100	6600	.12
		1	.67		1650		1650		.23
		2	.73		2200		2200		.35
1/2	.52	0	.76	3	75	5	75	4400	.16
		1	.81		1100		1100		.26
		2	.87		1625		1625		.37
3/4	.81	0	1.05	4	43	6	43	3200	.26
		1	1.10		898		898		.43
		2	1.16		1347		1347		.62
1	1.03	0	1.34	4.5	43	7	43	3000	.36
		1	1.42		718		718		.62
		2	1.50		1077		1077		.91
1-1/4	1.30	0	1.64	4	43	11	43	2900	.45
		1	1.72		645		645		.82
		2	1.80		968		968		.23
1-1/2	1.53	0	1.88	4.5	28	12	28	2260	.48
		1	1.95		531		531		.82
		2	2.02		797		797		1.23
2	2.50	0	2.48	5	14	13	14	2000	.70
		1	2.58		449		449		1.38
		2	2.69		674		674		2.14
2-1/2	2.61	0	3.33	5	12	16	18	1600	1.28
		1	3.45		400		400		2.09
		2	3.57		600		600		2.98
3	3.1	0	3.89	7.5	8	18	8	1150	1.53
		1	4.01		288		288		2.39
		2	4.13		431		431		3.35
4	3.98	0	4.83	10	5	22	5	1000	1.95
		1	5.03		250		250		3.14
		2	5.23		375		375		4.46

5	5.03	0	5.94	12	3.5	28	3.5	800	2.76
		1	6.10		200		200		4.08
		2	6.14		245		245		5.53
6	5.98	0	6.95	15	3	32	3	700	3.34
		1	7.15		175		175		4.79
		2	7.35		225		225		6.39
8	7.96	0	9.08	20	2.7	42	2.7	850	5.32
		1	9.44		212		212		8.73
		2	9.80		230		230		12.14
10	9.78	0	11.10	25	2.2	56	2.2	700	8.71
		1	11.49		175		175		12.65
		2	11.88		200		200		16.59
12	11.76	0	13.22	30	1.8	58	1.8	640	11.58
		1	13.51		160		160		17.53
		2	13.80		188		188		23.48

STYLE BN DATA SHEET

MATERIAL:

Hose: 321 or 316 stainless steel
Braid: 300 series stainless steel

CONSTRUCTION:

Annular butt-welded, mechanically formed close pitch corrugated hose.

Pressure applications:

Full vacuum to working pressures listed below.

UBN – UNBRAIDED HOSE

BN – SINGLE BRAIDED HOSE

DBN – DOUBLE BRAIDED HOSE

Nominal Diameter (Inches)	Actual ID (MM)	Number of Braids	Nominal OD (Inches)	STATIC		DYNAMIC		Burst Pressure @ 70° F (PSIG)	Weight Per Foot (Pounds)
				Minimum Bend Radius (Inches)	Maximum Working Pressure @ 70° F (PSIG)	Minimum Bend Radius (Inches)	Maximum Working Pressure @ 70° F (PSIG)		
1/4"	.25	0	.49	1.0	100	5.50	100	4,142	.13
		1	.57		1,035		1,035		.23
		2	.65		1,656		1,656		.33
3/8	.38	0	.67	1.25	40	6.00	40	2,738	.25
		1	.75		685		685		.36
		2	.83		1,095		1,095		.47
1/2	.50	0	.82	1.50	40	7.00	40	2,825	.38
		1	.90		706		706		.57
		2	.98		1,130		1,130		.76
3/4	.75	0	1.21	2.25	30	8.00	30	2,307	.50
		1	1.31		577		577		.83
		2	1.41		923		923		1.16
1	1.0	0	1.51	3.00	20	10.00	20	1,881	.68
		1	1.61		470		470		1.12
		2	1.71		752		752		1.56
1-1/4	1.25	0	1.85	3.50	15	12.00	15	1,443	.80
		1	1.95		361		361		1.31
		2	2.05		577		577		1.82
1-1/2	1.50	0	2.18	4.00	10	13.50	10	1,317	1.03
		1	2.31		329		329		1.73
		2	2.43		526		526		2.43
2	2.0	0	2.50	5.00	8	17.0	8	1,267	1.81
		1	2.63		317		317		2.73
		2	2.75		507		507		3.65
2-1/2	2.5	0	3.18	8.00	8	22.00	8	1,090	1.39
		1	3.31		272		272		2.66
		2	3.43		435		435		3.93
3	3.0	0	3.65	12.00	10	24.00	10	805	1.44
		1	3.78		201		201		2.84
		2	3.91		322		322		4.11
4	4.0	0	4.81	14.00	8	26.00	8	568	3.45
		1	4.94		142		142		5.03
		2	5.06		227		227		6.61

STYLE UN DATA SHEET

MATERIAL:

Hose: 321 or 316 stainless steel

Braid: 300 series stainless steel

Pressure applications:

Extremely flexible – ISO 10380 conformance, 50,000 cycle rated and pressure rated as per ISO 10380. Available in long lengths on reels.

CONSTRUCTION:

Annular butt-welded, mechanically formed close pitch corrugated hose.

UN20 - UNBRAIDED HOSE

UN21 - SINGLE BRAIDED HOSE

UN22- DOUBLE BRAIDED HOSE

* Contact Global-Flex for Specifications

Nominal Diameter (Inches)	Actual ID (MM)	Number of Braids	Nominal OD (Inches)	STATIC		DYNAMIC		Burst Pressure @ 70° F (PSIG)	Weight Per Foot (Pounds)
				Minimum Bend Radius (Inches)	Maximum Working Pressure @ 70° F (PSIG)	Minimum Bend Radius (Inches)	Maximum Working Pressure @ 70° F (PSIG)		
1/4"	6	0	.39	.35	392	5.50	2,030	11.165	.04
		1	.45	.75	4,829				
3/8	10	0	.63	.55	174	6.00	1,450	8,004	.23
		1	.70	1.14	3,727				
1/2	12	0	.73	.83	131	4.88	1,160	6,104	.10
		1	.79	1.34	2,973				
3/4	20	0	1.11	1.26	32	6.65	725	3,509	.15
		1	1.18	2.09	1,421				
1	25	0	1.37	1.46	26	7.68	580	2,755	.20
		1	1.43	2.52	972				
1-1/4	32	0	1.71	1.81	22	8.86	580	2,973	.33
		1	1.79	3.11	1,131				
1-1/2	40	0	2.06	2.16	17	10.04	465	2,465	.40
		1	2.14	3.86	885				
2	50	0	2.55	2.56	13	11.54	465	2,436	.64
		1	2.65	4.72	928				
2-1/2	65	0	3.19	3.15	10	13.58	363	1,871	.79
		1	3.28	5.90	623				
3	80	0	3.81	3.82	9	15.35	290	1,595	.94
		1	3.93	7.09	522				
4	100	0	4.63	4.45	7	17.72	218	1,247	1.12
		1	4.74	8.58	406				
5	125	0	5.98	5.20	6	25.60	232	928	3.04
		1	6.10	10.04	276				
6	150	0	6.85	5.98	4	32.08	210	841	3.48
		1	6.97	11.42	232				

STYLE HP DATA SHEET

MATERIAL:

Hose: 321 or 316 stainless steel

Braid: 300 series stainless steel

CONSTRUCTION:

Butt-welded, hydro-formed, heavy wall compressed hose with double braid

CHARACTERISTICS:

Ultra high-pressure hose for the most demanding pressure and flexing conditions

UNHP: Double braided hose

Nominal Diameter (Inches)	Actual ID (MM)	Number of Braids	Nominal OD (Inches)	Minimum Static Bend Radius (Inches)	Minimum Dynamic Bend Radius (Inches)	Maximum Working Pressure @ 70° F (PSIG)	Burst Pressure @ 70° F (PSIG)	Weight Per Foot (Pounds)
1/4	6	2	.51	2.80	5.20	3,988	15,950	.21
3/8	10	2	.76	3.00	5.50	3,117	12,470	.39
1/2	12	2	.86	4.00	7.10	3,165	12,658	.49
3/4	20	2	1/21	5.20	7.50	2,066	8,265	.74
1	25	2	1.57	6.70	9.00	2,004	8,018	1.23
1-1/4	32	2	1.93	7.50	10.00	1,653	6,612	1.68
1-1/2	40	2	2.26	8.50	12.80	1,334	5,336	2.08
2	50	2	2.75	10.80	16.00	1,294	5,176	2.82

Contact **Global-Flex Mfg.** for maximum test pressures

FITTINGS

Various fittings can be attached to metal hose. The fittings can be made of any material compatible with the hose and the media. Some of the most common ones are illustrated below.

MALE PIPE THREAD

Plain Nipples

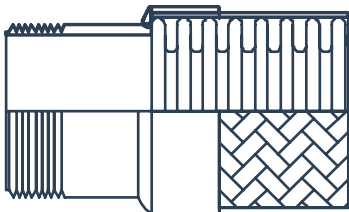

Male Pipe Hex

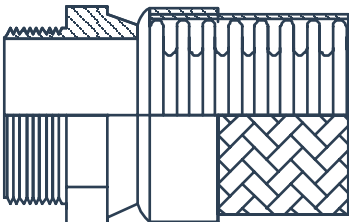

Female Union

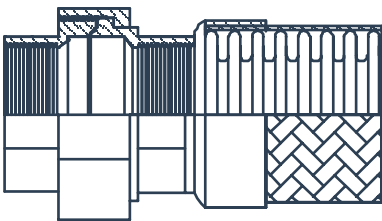

Half Coupling

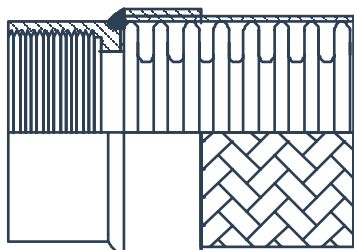

PLAIN WELD NIPPLES

Beveled For Welding

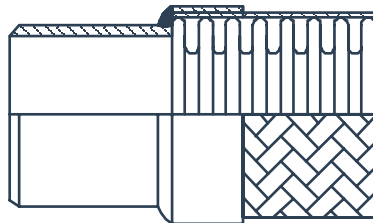

Grooved End

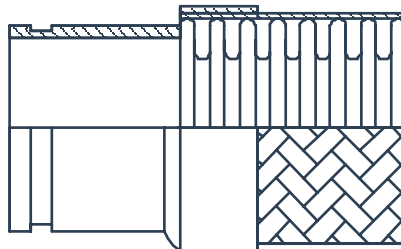

AN 818 Or J.I.C.
Female Swivel &
Other Tube Fittings

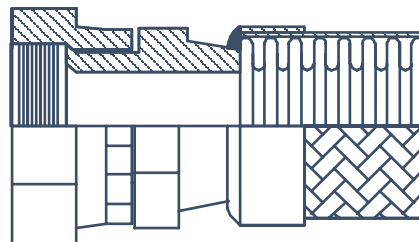

Other Fittings:

- Cam Lock
- Elbows
- Flanged Union
- Hydraulic
- Quick Disconnect
- Socket Weld
- Tees

STUB ENDS WITH FLOATING FLANGES

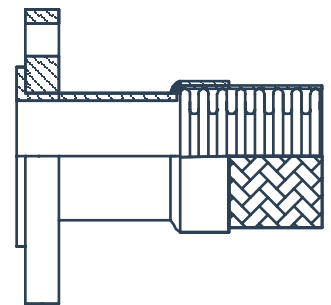
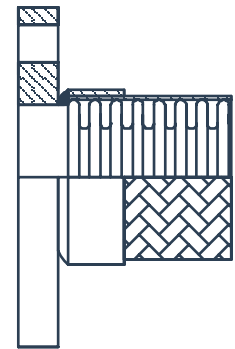
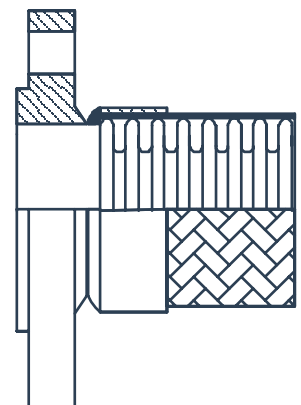

Plate Class D Fixed



Slip-On Raised Face 150,
300,600 lb Drilling



SPECIAL HOSE ASSEMBLIES FABRICATION

JACKETED ASSEMBLY

Jacketed Assemblies are normally used in one of the following applications:

1. As a heated transfer line for those products such as sulfur, which must be maintained at an elevated temperature in order to flow readily. Steam or hot oil is circulated through the jacket, which in turn heats the products being conveyed in the core hose.
2. As a cryogenic transfer line. Maintaining a high vacuum in the jacket effectively insulates cryogenic liquids being conveyed in the core hose.

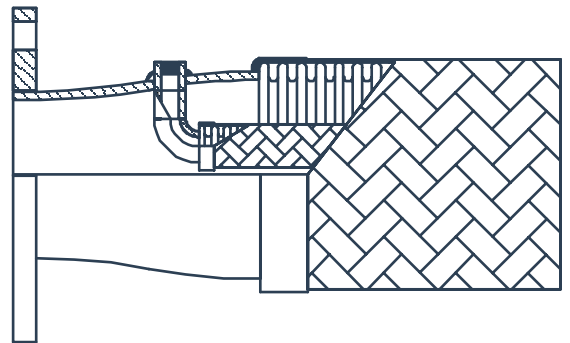
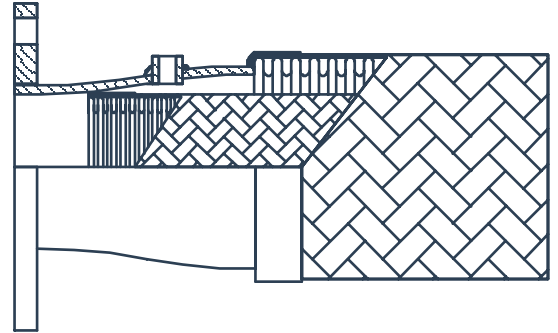

TRACED ASSEMBLY

Traced Assemblies are used when the product being conveyed must be heated in order to flow freely. Steam or hot oil circulated through the inner tracer hose heats the product in order to maintain high flow rates.

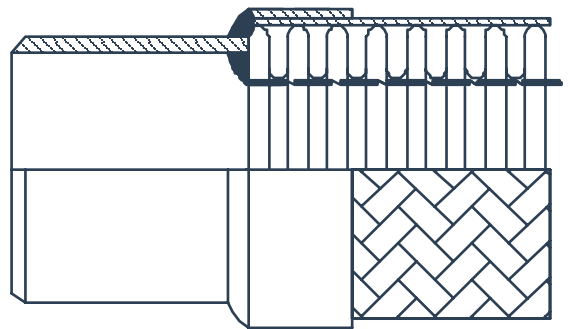

LINED ASSEMBLY

Product being conveyed through an unlined corrugated metal hose at high velocity can set up resonant vibration within the hose causing it to prematurely fail. This may be eliminated by adding a liner to the hose.

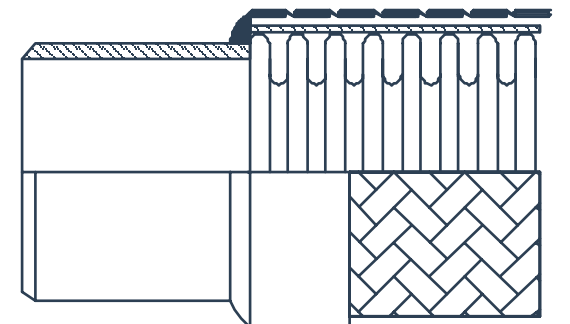

TRACED ASSEMBLY

Guarded Assemblies are used where rough handling, abrasion, or flexing past its minimum bend radius could easily damage a corrugated metal hose.

SELECTING METAL HOSE

Consider these selection factors for a particular application

1. SIZE OF CONNECTING PIPE

The size of metal hose for a given application is usually determined by the size of the existing piping and mating fittings. However, other considerations such as pressure drop, rate of flow, and velocity also influence your selection of the proper size of hose.

2. TEMPERATURE OF OPERATION IN RELATION TO PRESSURE AND MATERIAL

Temperature affects the physical properties of any material. This factor must be taken into account, as well as the working pressure and the specific applications. Hose type, metal alloy, fittings, and attachments determine the temperature limit.

3. MEDIA IN RELATION TO CORROSION OF HOSE MATERIAL

A primary consideration in specifying metal hose is to select a material, which is resistant to the media to be conveyed through the hose; this is possible in most applications. Remember to consider the corrosive effects of the outside environment, as well as the media conveyed within. Both factors are significant. Remember also that metal hose, a thin walled material, will not have the same life as pipe or tube that is a heavier-walled material, even though they are both of the same material.

4. PRESSURES – OPERATING, TEST AND BURST NEEDED FOR THE APPLICATION

The pressure rating for each type of flexible metal hose is affected by the conditions of actual use, such as, shock or pulsating conditions, temperature, and bending stresses. The maximum operating pressure is 25% of the *Nominal Burst Pressure*, while the maximum test pressure is 50% of the *Maximum Operating Pressure*. The Nominal Burst Pressure is the pressure at which the hose can be expected to rupture. When pulsating, surge or shock pressures exist, from conditions such as fast closing valves, the peak pressure should not exceed 50% of the Maximum Operating Pressure. Refer to our catalog that specifies the pressure ratings for each of these conditions, as it relates to both braided and unbraided hose. In addition, you should refer to the temperature chart for the pressure ratings as affected by temperatures in excess of 70° Fahrenheit.

5. MOTION TYPE AFFECTING HOSE AND AMOUNT OF MOTION

Flexible metal hose is specified for several different applications; whenever there is excessive vibration; whenever misaligned pipe or tube is encountered or whenever flexibility is needed for manual handling situations. To select the proper hose for any of these ap-

plications requires careful consideration of the inherent flexibility of the material in regards to the design of the assembly, installation and versatility expected of the hose.

6. LENGTH OF HOSE NEEDED TO ABSORB MOTION IN RELATION TO SPACE AVAILABLE.

The type of motion, the offset motion, vibration, as well as live length required, are all factors to consider in determining the proper hose selection. Refer to our catalog for exact specifications of these conditions.

7. FITTINGS NEEDED TO CONNECT TO EXISTING CONNECTIONS COMPATIBLE WITH MEDIA, TEMPERATURE, AND PRESSURE

End linings may have male or female threads. In addition to conventional unions – flanges, flared tube fittings – special designs or custom connectors are available. The appropriate type of hose, alloy and temperature determines the attachment method welding, soldering, silver brazing, or mechanical. Contact Global-Flex Mfg. for custom fitting information.

8. FLOW VELOCITY

High flow velocities in metal hose can cause vibration resulting in noise and premature failure.

INSTALLATION INFORMATION

AVOID TORQUE

Do not twist the hose assembly during installation when aligning the bolt holes in a flange or in mating up pipe threads. The utilization of lap joint flanges or pipe unions will minimize this condition. It is recommended that two wrenches be used in making the union connection: one to prevent the hose from twisting and the other to tighten the coupling.

PREVENT OUT-OF PLANE-FLEXING IN AN INSTALLATION

Always install the hose so that the flexing takes place in only one plane – this being the plane in which the bending occurs.

AVOID OVER BENDING

The repetitive bending of a hose to a radius smaller than the radius listed in the specification tables for corrugated hose will result in early hose failure. Always provide sufficient length to prevent over bending and to eliminate strain on the hose.

AVOID CARELESS HANDLING OF THE HOSE ASSEMBLY

Always lift or carry metal hose to prevent abrasion damage particularly to braided corrugated hose. Store metal hose assemblies away from areas where it can be subjected to spillage, corrosive fumes or sprays, weld splatter, etc.

ALWAYS SUPPORT THE PIPING

A piping system, which utilizes metal hose to absorb movement, must be properly anchored and/or guided. Always support the piping to prevent excessive weight from compressing the hose and relaxing the braid tension.

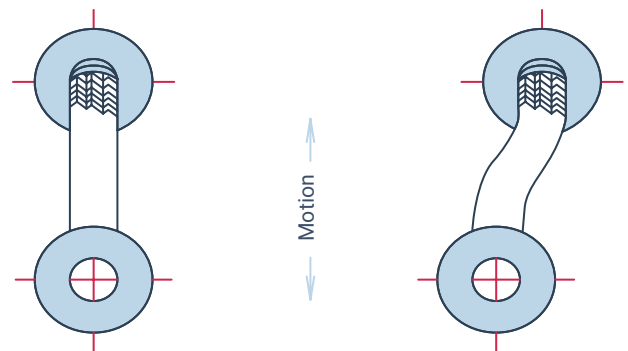
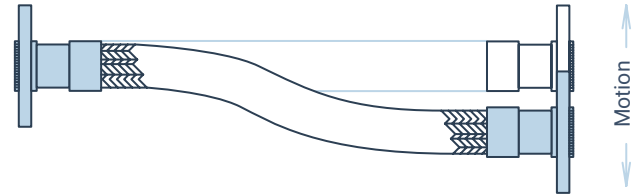

CORRECT
In plane flexing

WRONG
Out in plane flexing

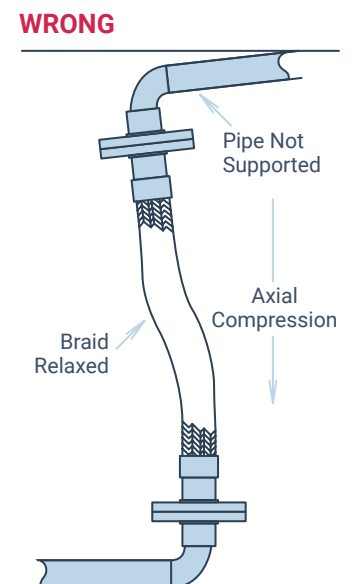
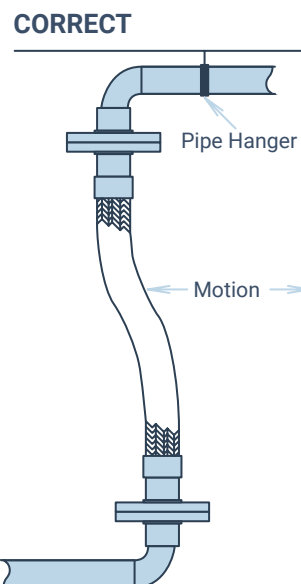

In Plain Traveling Loop Installation

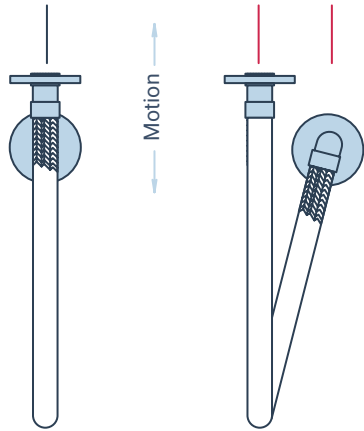
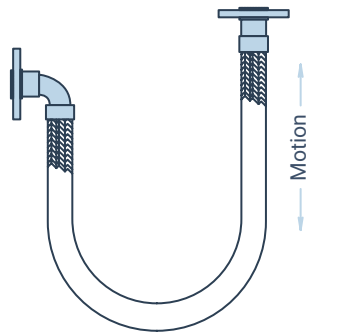

CORRECT
In plane flexing

WRONG
Out in plane flexing

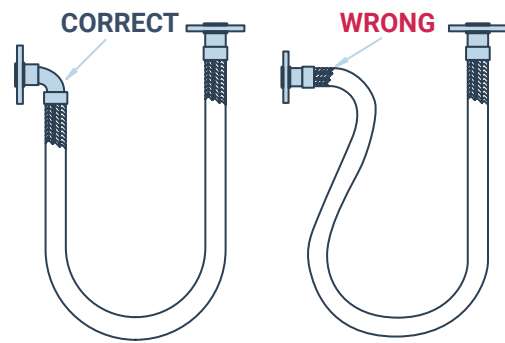
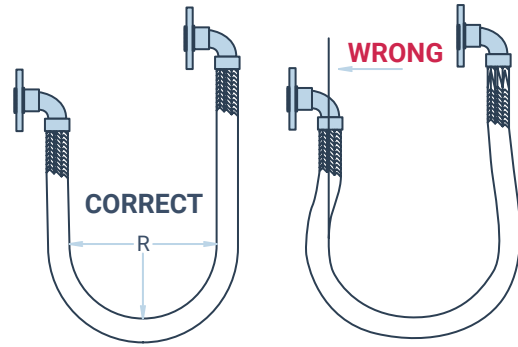

Constant Radius Traveling Loop - Class A

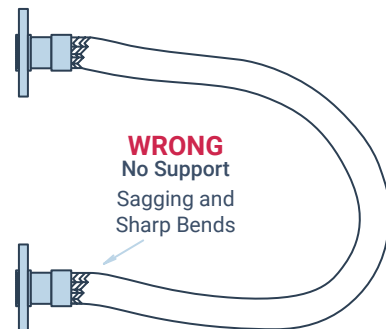
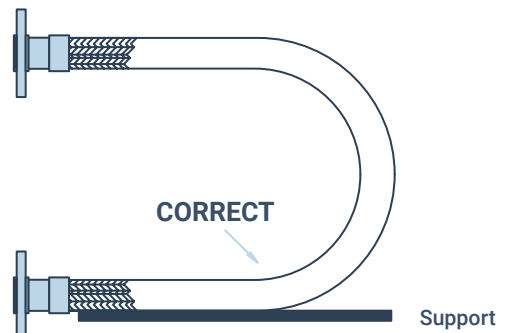
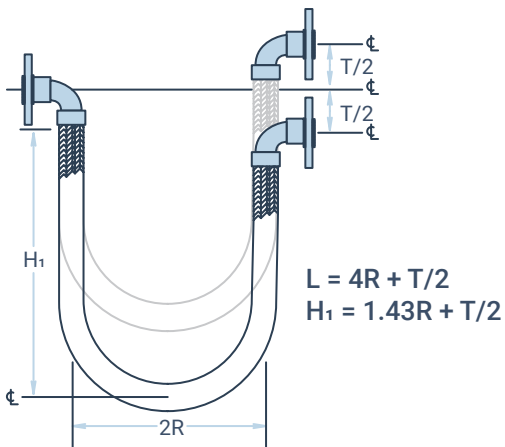
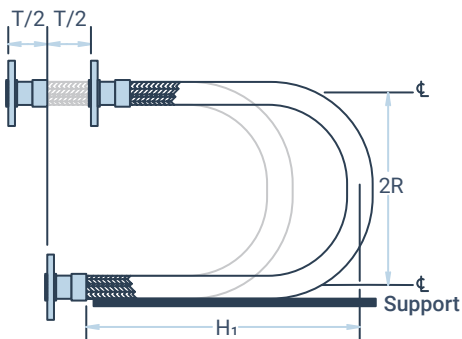

DO...

Follow any instructions included with the flexible connector .

Follow industry-recommended practices and use care in handling and installing flexible connectors

Install flexible connectors so the bend is as close to the center of the connector possible .

Observe the minimum bend radius as specified by the connector manufacture.

Trial-fit threaded connections by hand, unmake and then make permanent.

Use a flexible connector of proper length to suite the installation.

Only wrench on the fitting hex flats as provided
Design the installation to allow for ground movement after installation, such as settling or frost heave.

Install the proper length connector to allow a 2" straight rub of hose at each end of fitting.

Use pipe wrenches on both mating hexes to avoid twisting the hose.

Keep hose free from all objects and debris.

Handle and store connectors carefully prior to installation .

Check for leaks before covering the installation.

Install in such a manner that the connector can be removed.

Make sure the pressure rating of connector is not exceeded.

DO NOT...

Apply a wrench to the hose, or collar of the assembly.

Twist hose assemblies during or when aligning the bolt holes in a flange or when making up pipe threads.

"Pre-Flex" a flexible connector to limber it up. Over-bending could cause damage and result in leakage.

Over-bend a flexible connector. A 45-90 degree bend should be sufficient to install any flexible connector.

Install a flexible connector with the bend next to the end fitting. This could cause damage and result in leakage.

Lay the flexible connector on rocks or other objects which could puncture the hose and cause leakage.

Attempt to stretch or compress a flexible connector to fit an installation.

Restrict flexibility by allowing connectors to come into contact with other components or equipment during installation.

WORKING PRESSURE DERATING FACTOR FOR ELEVATED TEMPERATURES

TEMPERATURE IN DEGREES F.	WORKING PRESSURE DERATING FACTOR			
	T321/T316L	T321/T316L	T321/T316L	T321/T316L
70	1.00	1.00	1.00	1.00
150	.97	.96	.99	.92
200	.94	.92	.97	.89
250	.92	.91	.96	.86
300	.88	.86	.93	.83
350	.86	.85	.91	.81
400	.83	.82	.87	.78
450	.81	.80	.86	.75
500	.78	.77	.81	
600	.74	.73	.74	
700	.70	.69	.66	
800	.66	.64	.52	
900	.62	.58	.50	
1000	.60			
1100	.58			
1200	.55			
1300	.50			
1400	.44			
1500	.40			

To calculate a working pressure de-rated for elevated temperature: Multiply the hose working pressure shown in the catalog by the appropriate de-rating factor from above.

Note: The working pressure of an assembly at elevated temperatures may be affected by fittings type, material, and method of attachment.

OFFSET CHART

To determine the required live length of an application:

Find the specific bend radius from the general data sheet. Now, locate that bend radius on the chart below. From the offset (Y) across the top of the chart, locate the offset in inches. Read down to the bend radius and the number will be the live length required. Remember to always go to the next highest number in all calculations.

Example: UN series 1" diameter with an 1" offset is required.

Find the bend radius from the General Data Sheet for 1" hose – it is 7.68. Under bend radius on this chart go to 8. Follow across to the required offset, which is 1". The live length in this case would be 7". Note: If the offset (Y) occurs on both sides of the centerline, the live length is based on **the total travel or 2 times Y**.

BEND RADIUS	Offset Y (Inches)														
	0.25	0.50	0.76	1.00	1.25	1.50	2.00	2.50	3.00	4.00	5.00	6.00	8.00	10.00	12.00
.50	0.9	1.3	1.7	2.0	2.3	2.6	3.2	3.7	4.2	5.3	6.3	7.3	9.4	11.4	13.4
1	1.3	1.8	2.3	2.6	3.0	3.4	4.0	4.6	5.2	6.3	7.4	8.5	10.6	12.6	14.7
2	1.8	2.5	3.1	3.6	4.1	4.5	5.3	6.0	6.7	8.0	9.2	10.5	12.6	14.8	17.0
3	2.1	3.0	3.8	4.4	4.9	5.4	6.3	7.2	7.9	9.4	10.7	12.0	14.4	16.7	19.0
4	2.5	3.5	4.3	5.0	5.6	6.2	7.2	8.1	9.0	10.6	12.0	13.4	16.0	18.4	20.8
5	2.8	3.9	4.8	5.6	6.3	6.9	8.0	9.0	9.9	11.7	13.21	14.7	17.4	20.0	22.4
6	3.0	4.3	5.3	6.1	6.8	7.5	8.7	9.8	10.8	12.6	14.3	15.9	18.8	21.4	24.0
7	3.3	4.6	5.7	6.6	7.4	8.1	9.4	10.5	11.6	13.6	15.3	17.0	20.0	22.8	25.5
8	3.5	4.9	6.0	7.0	7.8	8.6	10.0	11.2	12.4	14.4	16.3	18.0	21.2	24.1	26.6
9	3.7	5.2	6.4	7.4	8.3	9.1	10.6	11.9	13.1	15.2	17.2	19.0	22.3	25.3	28.1
10	3.9	5.5	6.8	7.8	8.8	9.6	11.1	12.5	13.7	16.0	18.0	19.9	23.3	26.5	29.4
12	4.3	6.0	7.4	8.5	9.6	10.5	12.2	13.6	15.0	17.4	19.6	21.6	25.3	28.6	31.7
14	4.6	6.5	8.0	9.2	10.3	11.3	13.1	14.7	16.2	18.8	21.1	23.2	27.1	30.7	33.9
16	4.9	6.7	8.5	9.8	11.0	12.1	14.0	15.7	17.2	20.0	22.5	24.7	28.8	32.6	36.0
18	5.2	7.4	9.0	10.4	11.7	12.8	14.8	16.6	18.3	21.2	23.8	26.2	30.5	34.4	37.9

Global  Flex Mfg.

METAL HOSE NOTE PAD

SIZE

TEMPERATURE

APPPLICATION

MEDIUM

PRESSURE

END S

DELIVERY

METAL EXPANSION JOINT PRODUCTS

MEJ

Metal bellow expansion joints are available in basic low-corr, mid-corr, and high-corr construction, and in 50#, 150# and 300# pressure ratings. Single-ply bellows are standard, but multiple ply bellows are available. Either single or dual bellows can be selected, depending on the movement ratings needed. End configurations include weld type, fixed flange, or vanstone. Accessories such as tie rods, shroud covers and internal liners can be added to fit the application. Material options include 304, 321, and 316 SS, as well as Inconel, Monel, and other special alloys. Sizes available up to 144" diameter, depending on bellows type.

EJEP

Global-Flex Mfg. EJEP Externally Pressurized Expansion Joints are a packless, maintenance free product designed for use in straight runs of pipe to accommodate large amounts of thermal expansion. Within a protective enclosure, external pressure is applied to the bellows via a gap between the internal flange and housing. This pressure keeps the bellows stable. EP Series expansion joints are available in 150# and 300# designs with either flanged or weld ends. Both single and dual bellows are available. Drain ports can be added for steam service. Sizes range from 2" to 24" diameter.

MEJ-CF

Controlled-Flexing expansion joints combine corrugated metal bellows with mated neck rings and bellows equalizing rings. Corrugation movements are equalized, even at high pressures and large axial movements. Both 150# and 300# pressure styles are available. Internal liners can be added and external shroud covers can be installed for safety. Ends include fixed or vanstone flanges and weld end style. *Series MEJ-CF Controlled-Flexing Expansion Joints* are manufactured in sizes from 3" to 24" depending on bellows pressure series.

CM/CMS

Designed to control axial movements in small diameter piping systems. *Series CM/CMS Expansion Compensators* utilize the external pressurization principal to eliminate bellows squirm. Styles are available for connection to steel piping or copper tubing. Standard end configurations are threaded, copper sweat, or flanged. Sizes range from 3/4" to 4" diameter.

PB/PBR

Series PB/PBR Bellow Pump Connectors utilize a compact face-to-face, multi-ply construction to absorb noise and vibration generated by mechanical equipment. The longer style PBR is manufactured in the same lengths as standard rubber pump connectors and can offer substantial temperature and pressure advantages over rubber connectors. PB/PBR connectors are built with stainless steel bellows and carbon steel 150# flanges and limit rods.

SERIES PG – PIPE ALIGNMENT GUIDES

To insure the proper operation of piping expansion joints, *Global-Flex Mfg. Series PG Pipe Alignment Guides* should always be installed in the system. Series PG guides help to control the motion of pipe and expansion joints, insuring that the joint is subject only to the deflection for which it was designed. Guides permit unobstructed axial movement of the pipe while restricting lateral, angular, or buckling movements. Standard spider guides are manufactured to accommodate specific amounts of movement and insulation. Additional items in this series include pre-insulated guides, pipe slides and bases, anchor clamps, baseboard fin-tube guides, baseboard anchors, and hinged series.

SPECIAL DESIGN EXPANSION JOINTS

UNIVERSAL

Universal expansion joints are built with dual bellows and are tied the entire length of the expansion joint. This type of joint is the ideal product to control large amounts of lateral motion used in 90-degree elbow direction changes. Universal expansion joints can be used in pipe runs where extensive anchoring and guiding cannot be provided.

HINGED & GIMBALED

Hinged bellow expansion joints are designed to take up angular rotation in a single plane. Slotted hinged joints will accommodate axial and angular motion in one plane. Gimbale bellows will take up angular motion in all planes. Hinged and gimbale joints are typically used in combination to absorb many different movements.

PRESSURE BALANCED

Pressure balanced expansion joints incorporate elbows with single or universal bellows. The elbow is permitted to float free of bellows thrust forces. Main anchors are not required.

SLIP-PAK

When large amounts of axial movements must be absorbed at high pressures and temperatures, packed expansion joints are a wise choice. Slip-Pak joints are internally and externally guided and are available in single or dual configurations. Long service life can be insured by re-packing while in service, Meets MIL-E-17814E specifications.

RECTANGULAR

Rectangular bellows can be fabricated to take up movements in duct systems. A variety of alloys can be used to assure long life operation in high temperature conditions.

METAL EXPANSION JOINT PRODUCTS

Series MEJ Bellows Expansion Joints are constructed using multi-corrugation metal bellows, and flanged or weld type end connections. Accessories such as tie rods, limit rods, flow liners, and covers can be added, depending on the application. Free-flexing expansion joints are used to control axial pipe movements that typically arise due to thermal expansion. Limited lateral offset, angular rotation and vibration isolation can also be accommodated. Mid-corrugation bellows are an economical choice when average movements are experienced. High-Corr bellows should be used to absorb greater movements. Where expected motions are greater than what a single bellows can accommodate, dual bellows with a center anchor base can be used. Bellows pressure carriers include low-pressure exhaust bellows, 50 psi, 150 psi, and 300 psi. Single-ply bellows are standard. Multi-ply bellows are well suited for those applications for low spring rate or cyclical vibration applications. Standard materials include T304, 321, and 316 stainless steel, as well as Inconel, Monel, and other alloys. Meets MIL-E-17813F Type 1, Class 1 and Class 2.



BASIC CONFIGURATIONS

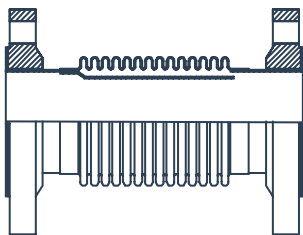

FLANGE

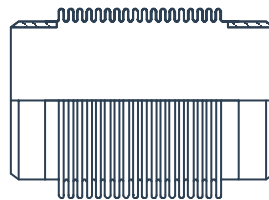

WELD ENDS

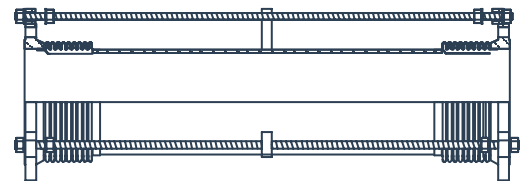

UNIVERSAL FLANGE TIED

EJEP

Externally pressurized expansion joints, are designed with an uncompromising standard of quality, for years of maintenance free operation in distribution pipelines conveying liquids or gases

FLANGES - To insure pressure tight sealing, raised face slip on flanges in full compliance with ANSI B 165 are standard. Flange material is either ASTM A-105 (Forged) or ASTM A36 (Plate). Lap joint flanges can be furnished as an option to permit easy alignment of bolt holes. Alloy ends are available where additional corrosion resistance may be required.

INTERNAL/EXTERNAL GUIDES - Guide rings are welded to inner end of pipe and outer cover. They are designed to provide accurate guiding of bellows as the pipeline expands or contracts. This insures bellows will not be scored or subject to movement for which it was not designed to accommodate.

COVER - Designed for full line pressure to insure in the unlikely event of a bellows failure media will not escape radically outward.

DRAIN - Provides a convenient location for installing a steam trap. May also be used to drain liquids when pipeline is shut down.

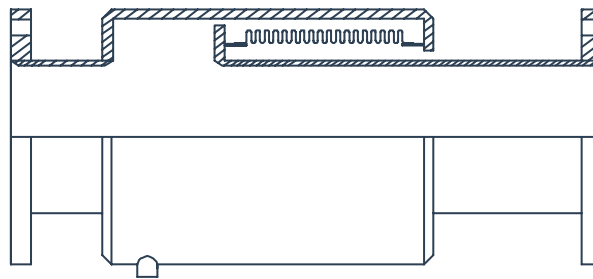

BELLOWS - Single or multiply bellows are precision formed from cylinders of deep drawn quality annealed sheet conforming to ASTM specifications. Type 304 is standard and suitable for most chloride-free applications such as steam, condensate, oil, chill water. Where chlorides may be present, Inconel 600 bellows should be specified.

BASE - Standard on double designs, optional on single designs. Base is designed as a support or intermediate anchor. Main anchor base designed for full pressure thrust loading is optional.

AVAILABLE - Single and double units for axial compression up to 16 inches. 150 and 300 lb design.

INTERNAL LINER - Carbon steel pipe liners standard and designed to prevent bellows fatigue failure due to flow induced vibration.

FIVE YEAR WARRANTY

Global-Flex style EJEP are warranted to be free of defects in material and workmanship under normal use and service for a period of 5 years from the date of shipment. This warranty applies only to parts which are manufactured and delivered by Global-Flex Mfg.

In the event of failure of a part due to a covered defect, Global-Flex Mfg. will repair or replace at its option the defective part at its factory located at 1580 Charles Dr., Redding, Ca. 96003. The part must be returned to the factory by and at the expense of the person claiming the benefit of the warranty. The only entity authorized to do any warranty repairs is the manufacturer.

This warranty is expressed in lieu of all other warranties, expressed or implied, including the implied warranty of fitness for a particular purpose, and of all other obligations or liabilities on the part of Global-Flex Mfg. and it neither assumes nor authorizes any other persons to assume for Global-Flex Mfg. any other liabilities in connection with the sale of the products. This warranty does not cover parts of products made by others or products or any part thereof which have been repaired or altered, except by Global-Flex Mfg. or which shall have been subjected to misuse, negligence, or accident.

Global-Flex Mfg. shall not be liable for damage or delay suffered by the purchaser regardless of whether such damages are general, special, or consequential in nature, whether caused by defective material or workmanship or otherwise or whether caused by Global-Flex Mfg. negligence regardless of the degree.

** copy -WARRANTY12-08.DOC

SERIES CM/CMS

EXPANSION COMPENSATORS

DESCRIPTION & APPLICATIONS:

Series CM/CMS Expansion compensators are the most economical choice for the compensation of thermal growth in small diameter piping systems. Global-Flex expansion compensators are commonly used in HVAC systems and other systems such as steam condensate. **Series CM/CMS** Expansion Compensators are a high pressure, externally pressurized design, available in sizes from 3/4" through 4". **Style CM**, male pipe threaded is for connection to steel piping, while **Style CMS** Sweat ends are for connection to copper tubing. The 2-ply stainless steel bellows works in conjunction with an anti-torque device. All sizes permit 2" of axial motion.



DESIGN SPECIFICATIONS FOR MALE PIPE

Pipe Size Inches	Number	Pressure		Overall Length Inches	Outside Diam. Inches	Size Inches	Effective Area in Sq In	Weight lbs
		Max WP PSI	Test PSI					
1	CM-100	200	300	12-1/8	3-1/2	1	3.5	7.0
1-1/4	CM-125	200	300	14-1/8	4	1-1/4	4.8	10.2
1-1/2	CM-150	200	300	14-1/8	4-1/2	1-1/2	6.5	12.3
2	CM-200	200	300	14-1/8	4-1/2	2	7.6	13.2
2-1/2	CM-250	200	300	15-1/2	5-1/2	2-1/2	12.9	19.6
3	CM-300	200	300	15-3/16	6-1/2	3	16.1	24.4
4"	CM-400	200	300	15-3/16	7-3/32	4	24.2	27.5

DESIGN SPECIFICATIONS FOR MALE PIPE AND WELD ENDS

Pipe Size Inches	Number	Pressure		Overall Length Inches	Outside Diam. Inches	Size Inches	Effective Area in Sq In	Weight lbs
		Max WP PSI	Test PSI					
1	CMS-100	200	300	12-1/2	2-3/8	1	2.2	2.4
1-1/4	CMS-125	200	300	13-13/16	2-3/4	1-1/4	3.5	3.1
1-1/2	CMS-150	200	300	13-13/16	2-3/4	1-1/2	3.5	3.3
2	CMS-200	200	300	13-13/16	3-3/4	2	6.5	5.5
2-1/2	CMS-250	200	300	14-7/16	4-3/8	2-1/2	9.6	7.5
3t	CMS-300	200	300	14-7/16	5	3	12.9	10.0

Style PB & PB-R

Multi Ply Bellows Pump Connectors

Global-Flex Mfg. Series BP & PB-R Bellows Pump Connectors are designed to absorb noise and vibration generated by mechanical equipment. In addition, these compact length connectors will take-up axial and lateral motion. Series **PB** connectors utilize a highly flexible multi-ply Type 304 stainless steel bellows construction for greater movement absorbing abilities a pump connectors, and can offer substantial temperature and pressure and longer life. The longer Style **PB-R** is manufactured in the same lengths as standard rubber pump connectors, and can offer substantial temperature and pressure advantages Special 150# ANSI flanges and limit rods are carbon steel. Sizes range from 2" to 14" diameter.

FEATURES:

- T-304 2-Ply Construction
- AISI-1020 Tie Rods
- Noise and Vibration dampening
- ANSI 150 Carbon Steel Flanges
- Compression Sleeves (304) SS
- High pressure ratings 225 PSIG
- Temperature Rating up to 750 F
- Rated for Full Vacuum

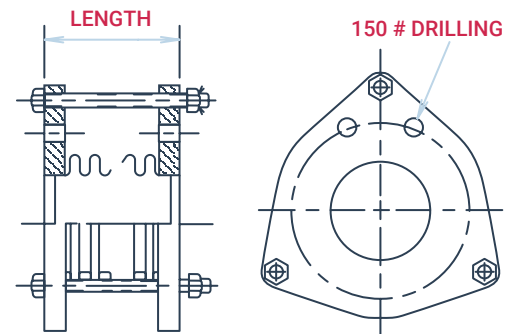
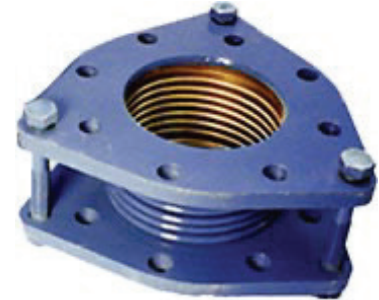

Global-Flex Part No.	Size Inch	Length Inch	Flange O.D.	Bolt Cir Dia.	No of Bolt Holes	Bolt Hose Dia.	Bellows		Working Pressure	Axial Comp	Axial Ext	Lateral	Weight
							No. Ply	Material					
PB-200	2	4-3/8	6	4.75	4	.75	2	T304	225	.50	.125	.125	14
PB-250	2-1/2	4-3/8	7	5.5	4	.75	2	T304	225	.50	.125	.125	16
PB-300	3	4-3/8	7.5	6.0	4	.75	2	T304	225	.50	.125	.125	20
PB-400	4	4-5/8	9	7.5	8	.75	2	T304	225	.50	.125	.125	28
PB-500	5	4-7/8	10	8.5	8	.875	2	T304	225	.50	.125	.125	34
PB-600	6	5.0	11	9.5	8	.875	2	T304	225	.50	.125	.125	43
PB-800	8	5-7/8	13.5	11.75	8	.875	2	T304	225	.50	.125	.125	63
PB-1000	10	6-1/4	16	14.25	12	1	2	T304	225	.50	.125	.125	93
PB-1200	12	6-5/8	19	17	12	1	2	T304	225	.50	.125	.125	120
PB-R-200	2	6	6	4.75	4	.75	2	T304	225	1.0	.125	.125	14
PB-R-250	2-1/2	6	7	5.5	4	.75	2	T304	225	1.0	.125	.125	16
PB-R-300	3	6	7.5	6.0	4	.75	2	T304	225	1.0	.125	.125	20
PB-R-400	4	6	9	7.5	8	.75	2	T304	225	1.0	.125	.125	28
PB-R-500	5	6	10	8.5	8	.875	2	T304	225	1.0	.125	.125	34
PB-R-600	6	6	11	9.5	8	.875	2	T304	225	1.0	.125	.125	43
PB-R-800	8	6	13.5	11.75	8	.875	2	T304	225	1.0	.125	.125	63
PB-R-1000	10	8	16	14.25	12	1	2	T304	225	1.0	.125	.125	93
PB-R-1200	12	8	19	17	12	1	2	T304	225	1.0	.125	.125	120

PIPE ALIGNMENT GUIDES SERIES PG

SPECIAL APPLICATIONS PRODUCTS



PGL LIGHT GUIDES
For low Pressure applications



Extra Travel



ANCHOR CLAMPS



**BASEBOARD
FIN-TUBE GUIDE**



BASEBOARD ANCHOR

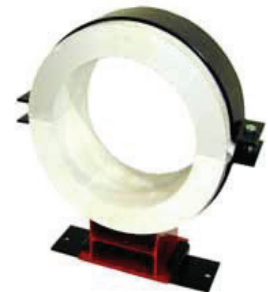

**PRE-INSERTED
PIPE HANGER INSERT**



257 Series

*CONTACT GLOBAL-FLEX MFG FOR SPECIFIC INFORMATION ON SIZE,
DIMENSIONS, AND APPLICATIONS FOR THESE PRODUCTS*

PIPE ALIGNMENT GUIDES

SERIES PG

RECOMMENDATION FOR PLACEMENT

It is recommended that an expansion joint be located as near to an anchor as possible. The first guide should be located within **4 pipe diameters** of the expansion joint. The **second guide** should be located within **14 pipe diameters** of the expansion joint. The remaining intermediate guides are placed at the approximate distance shown in the INTERMEDIATE GUIDE SPACING CHART.

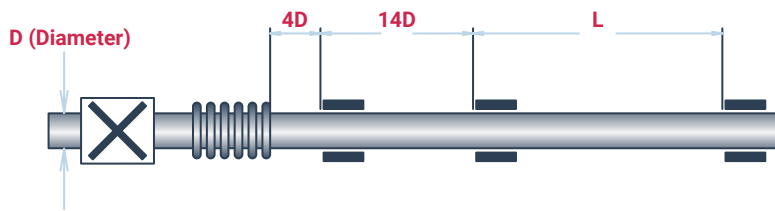

MINIMUM GUIDE SPACING

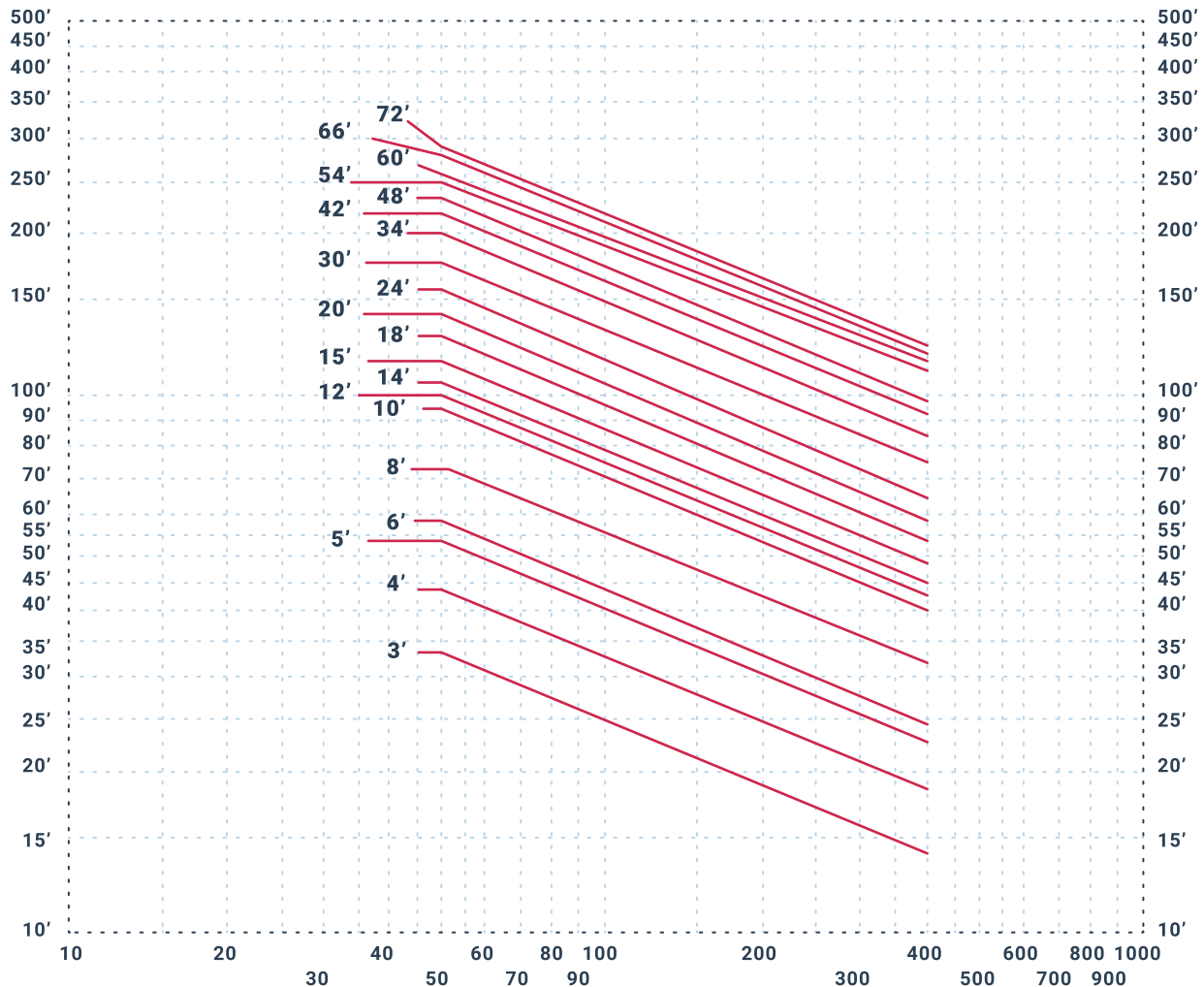

DESCRIPTION & APPLICATIONS:

UNIVERSAL

The universal design consists of dual bellows which are tied the entire length of the expansion joint. Universal expansion joints are typically used to accommodate large amounts of lateral motion. When they are used in conjunction with 90 degree piping direction changes, they can be used in pipe runs where extensive anchoring and guiding cannot be provided. Force required to offset is low provided adequate length is available. As the length between the bellows increases, the spring rate decreases.

HINGED & GIMBALED

In applications where only angular movement is to be allowed, hinged and gimbaled expansion joints are the solution. Hinged joints are designed to take up angular motion in a single plane. Slotted hinge expansion joints permit axial movement through use of a slot, and require main anchors. Gimbaled bellows will allow angular motion in all planes. Hinged and gimbaled joints are commonly used in combination to absorb various movements.

PRESSURE BALANCED

An elbow style expansion joint designed for applications involving 90-degree change in direction and applications where main anchors cannot be placed in the system. The elbow is permitted to float free of bellows thrust forces. Either single or dual bellows pressure balanced is available. In-line pressure balanced expansion joints are constructed for axial applications of straight runs of pipe that cannot provide main anchors to react to the pressure thrust of the expansion joint.

RECTANGULAR

Rectangular metallic bellows expansion joints are fabricated to absorb vibration and thermal movements in duct systems. High profile, low spring-rate corrugations will allow for large amounts of movement in short face-to-face designs. Flanges can be either internal or external. A variety of alloys can be used to assure trouble-free operation in high temperature conditions. Axial, lateral, and angular movement can all be accommodated. Similar, low-pressure bellows are also manufactured for circular duct systems.

Global  Flex Mfg.

MEJ NOTE PAD

SIZE

TEMPERATURE

APPPLICATION

MEDIUM

PRESSURE

EENDS

DELIVERY

A Required Axial
Compression/Extension

L Required Lateral
Movement

RUBBER EXPANSION JOINT PRODUCTS

REJ

Global-Flex style REJ “Made in USA” expansion joints are the ultimate in quality hand-built construction. Premium grade elastomers provide long service life in the most demanding applications. For superior performance and pressure ratings **Global-Flex style REJ** expansion joints have a minimum **4 to 1 safety factor** built in to their rated operating pressures.

REJM

Global-Flex Mfg. Style REJM expansion joints are the ultimate in quality molded construction. Premium grade elastomers provide long service life in the most demanding applications. For superior performance and pressure ratings **Global-Flex style REJ** expansion joints have a minimum **4 to 1 safety factor** built in to their rated operating pressures. Working pressure up to 200 psi.

REJZ

Global-Flex Mfg. Style REJZ expansion joints are the ultimate for use in low spring rate applications. The light weight construction lowers forces exerted on the mating flanges. This improved flexibility allows for easier installation.

REJ-TN

Global-Flex Mfg. Style REJ-TN expansion joints combined the best features of Teflon with the best features of elastomeric expansion joints. Joints are available in 1” up to 24” I.D. in standard face-to-face dimensions, or special lengths. Also available in multiple arch configurations or as straight pipe.

REJU, REJW, REJV

Global-Flex Mfg. Style REJU, REJW, REJV expansion joints are elastomeric in both body and flange and are available in Neoprene, Hypalon, EPDM, Butyl, or Viton. Thinner in overall gauge helps to protect thin wall duct systems. Standard circular expansion joints have integral duck and rubber flanges drilled to order. Rectangular style also incorporates rubber flanges, utilizing square corners and special drilling. “Continuous corners” eliminate splices through the body of the expansion joint near the corners. The inherent flexibility of rubber provides long service life even in applications of high vibration or flutter.

STYLE REJ SPOOL

HAND BUILT WIDE ARCH DESIGN EXPANSION JOINT “MADE IN USA”

For demanding applications, and excessive pipe movements, Global-Flex Style REJ-Spool wide arch expansion joints provide greater flexibility and longer service life.

Global-Flex Style REJ expansion joints are the ultimate in quality hand-built construction. Premium grade elastomers provide long service life in the most demanding applications. For superior performance and pressure ratings **Global-Flex Style REJ** expansion joints have a minimum **4 to 1 safety factor** built in to their rated operating pressures.

Global-Flex Style REJ expansion joints offer an improved ‘wide arch’ design. Face-to-face measurements of the **Global-Flex style REJ** expansion joints are equal to that of standard or multi-arch joints, but will **accommodate much greater movements**.

The **Global-Flex Style REJ** expansion joints are manufactured domestically, with premium grade materials. Construction consists of a tube, integral duck and rubber flanges, carcass, internal steel reinforcements, cover, and steel retaining rings. The tube consists of a single piece of leak proof lining extending flange-to-flange. Carcass construction is a strong, bias-ply, high-strength woven polyester fabric between the tube and cover. The fabric is thoroughly impregnated with a special friction compound to give maximum adhesion under pressure, vacuum, and stress conditions. Special steel rings embedded in the carcass provide strength while under pressure or vacuum. Also the wide arch design provides a self-flushing profile, reducing turbulence, and sediment build-up.

The Global-Flex Style REJ comes standard with a chlorobutyl tube and a Hypalon cover. These elastomers provide excellent resistance against heat



and a wide variety of fluids. The standard Hypalon cover, versus Hypalon paint, provides extra protection against abrasion, ozone, weathering, heat and many chemicals.

Other elastomers available are gum, natural rubber, EPDM, Nitrile, Neoprene, Viton, and Teflon. Galvanized steel split retaining rings are standard, but can also be ordered in stainless steel.

Global-Flex Style REJ are available in filled arches, multiple arches, sleeve type, tapered (eccentric or concentric) and offset constructions. Requirements of up to 50% greater pressures and/or temperatures up to 400 degrees F can also be accommodated. **Global-Flex Style REJ** expansion joints can be manufactured in accordance with ASTM designation FI 123-87 and meet all USCG requirements for shipboard service.

Control unit assemblies are always recommended in unanchored systems and in connection to spring mounted equipment. Properly installed, these units will protect against excessive elongation, and with optional sleeve, against over-compression—both of which can seriously damage rubber expansion joints.

STYLE REJ SPOOL

“MADE IN USA”

Hand-Built Wide Arch Expansion Joint

Global-Flex Style REJ expansion joints are manufactured to meet or exceed the pressure, movement, and dimensional ratings of the Rubber Expansion Joint Division, Fluid Sealing Association.

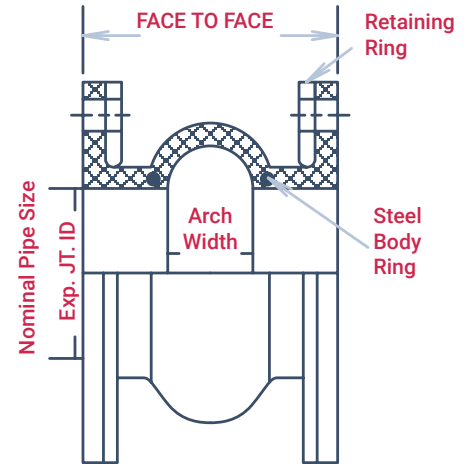

SPECIFICATIONS

ALLOWABLE MOVEMENTS/WEIGHTS STYLE REJ SINGLE ARCH

SIZE	FACE TO FACE	WORKING PRESSURE	MOVEMENTS				WEIGHT (LBS) RINGS INCLUDED
			COMPRESSION (Inches)	ELONGATION (Inches)	LATERAL (Inches)	ANGULAR DEGREE	
2	6	225	1.75	.75	.75	35	8.0
2-1/2	6	225	1.75	.75	.75	30	10.0
3	6	225	1.75	.75	.75	30	11.5
4	6	225	1.75	.75	.75	25	15.5
5	6	225	1.75	.75	1.00	25	17.0
6	6	225	1.75	.75	1.00	20	20.0
8	6	225	1.75	.75	1.00	20	27.0
10	8	225	1.75	.75	1.00	15	39.0
12	8	225	1.75	.75	1.00	13	56.0
14	8	225	1.75	.75	1.00	11	65.0
16	8	160	1.75	.75	1.00	10	74.0
18	8	160	1.75	.75	1.00	9	85.0
20	8	130	1.75	.75	1.00	8	102.0
22	10	130	1.75	.75	1.00	7.8	114.0
24	10	130	1.75	1.00	1.00	7	125.0

STYLE REJ AVAILABLE IN SIZES UP TO 96" CONTACT GLOBAL-FLEX MFG

Temperature Limits for Continues Service	
REJ	250 deg F
REJ HT	300 deg F
REJ V	400 deg F
ALL JOINTS ARE RATED FOR FULL VACUUM SERVICE	

MINIMUM FACE -TO - FACE DIMENSIONS			
	REJ SINGLE F/F (INCH)	REJ-D F/F (INCH)	REJ-T F/F (INCH)
½ to 6	6	12	16
8	6	12	18
10	8	16	20
12	8	16	20
14 to 20	8	16	20
22 to 30	10	16	22

STYLE CREJ SPOOL

CONCENTRIC DESIGN

The Global-Flex Mfg series CREJ is designed to facilitate the transition of pipe sizes in most systems. The concentric design is used to mate differing pipe ID's where the centerline of the pipes match. 100% domestically constructed these joints are custom manufactured in a variety of elastomers and size configurations, to meet the necessary temperature, movement and pressure requirements of your system.

Temperature Limits for Continuous Service

CREJ		250 Deg F
CREJ	H	300 Deg F
CREJ	V	400 Deg F

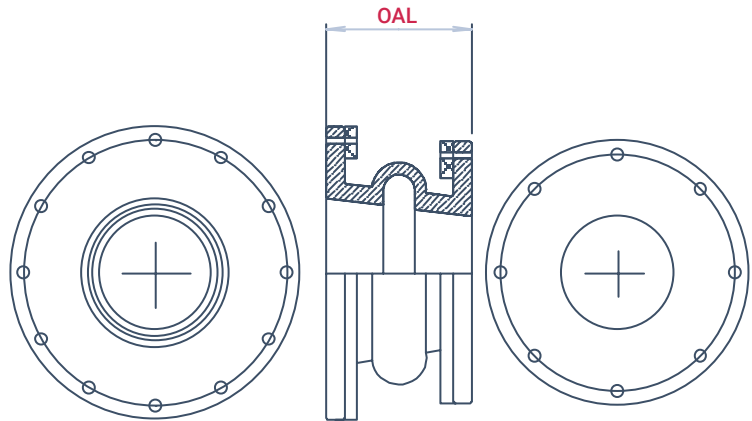

STYLE EREJ SPOOL

ECCENTRIC DESIGN

The Global-Flex Mfg series EREJ is another in the series of rubber expansion joints designed to help connect different size pipes in a system. The eccentric design is used in connections where the differing size pipes have no common centerline. 100% domestically constructed, these joints are custom manufactured in a variety of elastomers and size configurations, to meet the necessary temperature, movement and pressure requirements of your system.

Temperature Limits for Continuous Service

EREJ		250 Deg F
EREJ	H	300 Deg F
REJ	V	400 Deg F

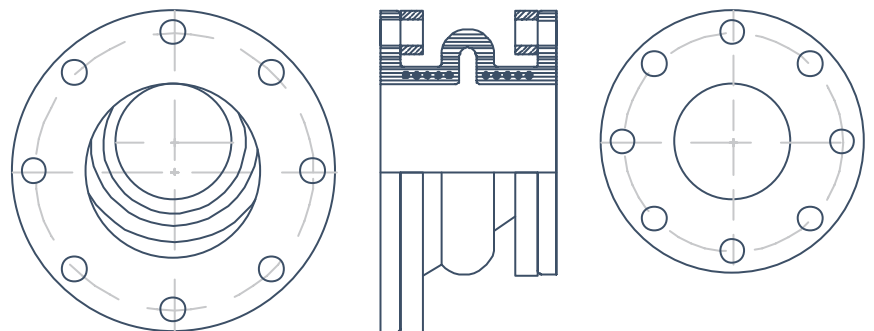

STYLE REJM

RUBBER EXPANSION JOINT

Global-Flex Mfg. Style REJM expansion joints are the ultimate in quality molded construction. Premium grade elastomers provide long service life in the most demanding applications. For superior performance and pressure ratings **Global-Flex Style REJM** expansion joints have a minimum **4 to 1 safety factor** built in to their rated operating pressures. Working pressure up to 200 psi.

Global-Flex Mfg. Style REJM comes standard with a chlorobutyl tube and cover. These elastomers provide excellent resistance against heat and a wide variety of fluids.

Features:

- Allow for greater motions capabilities than standard arch expansion joints.
- Excellent for absorbing thermal expansion, and eliminating vibration and sound.
- Gasket and packing not required.
- Absorbs water pulsations and protects start-up surge force vacuum ratings to 25 Hg.

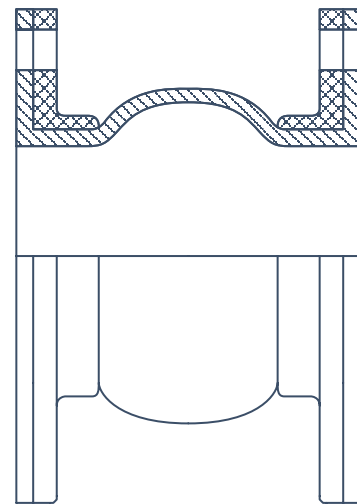

I.D.	Face/ Face Inch	Flange O.D.	Bolt Cir Dia.	No of Bolt Holes	Bolt Hole Dia.	Working Pressure	Axial Comp	Axial Ext	Trav Defl	Weight
2	6	6	4.75	4	.75	200	1.75	.75	.75	4
2-1/2	6	7	5.5	4	.75	200	1.75	.75	.75	4.5
3	6	7.5	6.0	4	.75	200	1.75	.75	.75	5.5
4	6	9	7.5	8	.75	200	1.75	.75	.75	8
5	6	10	8.5	8	.875	200	1.75	.75	.75	9
6	6	11	9.5	8	.875	200	1.75	.75	1	11
8	6	13.5	11.75	8	.875	180	1.75	.75	1	15
10	8	16	14.25	12	1	180	1.75	.75	1	23
12	8	19	17	12	1	180	1.75	.75	1	34

STYLE REJZ LOW SPRING RATE RUBBER EXPANSION JOINT

Global-Flex Mfg. Style REJZ expansion joints are the ultimate for use in low spring rate applications. The light weight construction lowers forces exerted on the mating flanges. This improved flexibility allows for easier installation.

Global-Flex Mfg. Style REJZ comes standard with an EPDM tube and cover, while other compound's are available.

Features:

- Increased movements capabilities.
- Excellent pressure capabilities.
- Light weight construction.
- Absorbs water pulsations and start-up surge force.
- Excellent for PVC pipe runs.

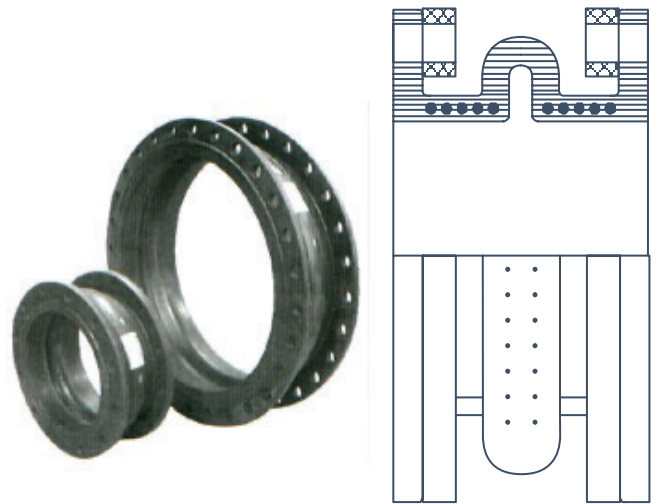

I.D.	Face/ Face Inch	Flange O.D.	Bolt Cir Dia.	No of Bolt Holes	Bolt Hole Dia.	Working Pressure	Axial Comp	Axial Ext	Lateral	Ang Deg
2	6	6	4.75	4	.75	225	1.50	.63	.75	25.00
2-1/2	6	7	5.5	4	.75	225	1.50	.63	.75	20.25
3	6	7.5	6.0	4	.75	225	1.50	.63	.75	18.00
4	6	9	7.5	8	.75	225	1.50	.63	.75	14.25
5	6	10	8.5	8	.875	225	1.50	.63	.75	13.00
6	6	11	9.5	8	.875	225	1.50	.63	.75	12.25
8	6	13.5	11.75	8	.875	210	1.50	.63	.75	12.00
10	8	16	14.25	12	1.0	210	2.25	.75	1.0	11.90
12	8	19	17	12	1.0	210	2.25	.75	1.0	11.55
14	8	21	18.75	12	1.0	150	2.25	.75	1.0	11.30
16	8	23.5	21.25	16	1.0	150	2.25	.75	1.0	10.12
18	8	25.0	22.75	16	1.0625	150	2.25	.75	1.0	8.95

STYLE REJ-TN RUBBER TEFLON EXPANSION JOINT

“MADE IN USA ALL DOMESTIC”

Global-Flex Mfg. Style REJ-TN expansion joints combined the best features of Teflon with the best features of elastomeric expansion joints. Joints are available in 1” up to 24” I.D. in standard face-to-face dimensions, or special lengths. Also available in multiple arch configurations or as straight pipe.

Style REJ-TN joints are recommended for use in the chemical and pulp paper industries because of their capabilities to resist corrosive attack along with high temperatures and pressures.

Features:

- Features:
- Chlorine Resistance
- Anti-stick properties
- Noise and Vibration dampening
- High Flexibility
- Thermal Stability
- Resistance to age cracking
- High pressure ratings
- Temperature rating up to 400 F

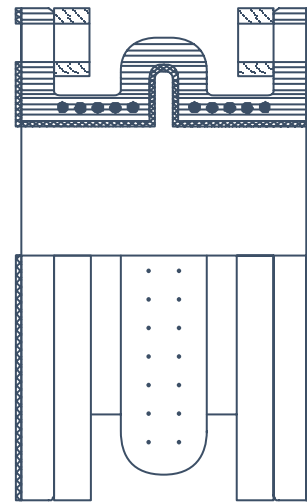
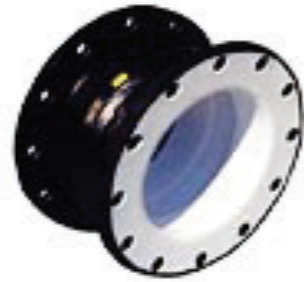

I.D.	Face/ Face Inch	Flange O.D.	Bolt Cir Dia.	No of Bolt Holes	Bolt Hole Dia.	Arch Height/ Width		Working Pressure	Axial Comp	Axial Ext	Trav Defl	Weight
						D	D					
2	6	6	4.75	4	.75	1.25	1.75	225	1.75	.75	.75	4
2-1/2	6	7	5.5	4	.75	1.25	1.75	225	1.75	.75	.75	4.5
3	6	7.5	6.0	4	.75	1.25	1.75	225	1.75	.75	.75	5.5
4	6	9	7.5	8	.75	1.25	1.75	225	1.75	.75	.75	8
5	6	10	8.5	8	.875	1.25	1.75	225	1.75	.75	.75	9
6	6	11	9.5	8	.875	1.25	1.75	225	1.75	.75	1	11
8	6	13.5	11.75	8	.875	1.5	1.75	225	1.75	.75	1	15
10	8	16	14.25	12	1	1.5	1.75	225	1.75	.75	1	23
12	8	19	17	12	1	1.5	1.75	225	1.75	.75	1	34

SERIES SE DE SN DN SPHERES

A long time work horse of light duty and HVAC applications.

The Global-Flex SE, DE, SN, & DN series of rubber expansion joints continues to offer an economical solution to handle vibration, sound attenuation and movement in piping systems (available in sizes 1-1/2 through 24 inch).

The imported molded design is readily available in standard face to face dimensions and an ideal choice when used as a pump connector. The standard design is available in single or double arch the body is constructed using either a polyester reinforced Neoprene or EPDM elastomer.

In addition, the integrated, 150# plated carbon steel rotating flanges make connections quick and simple.

Global-Flex Mfg. offers several flange options - stainless steel, 300 #, and metric drilling is available upon request.

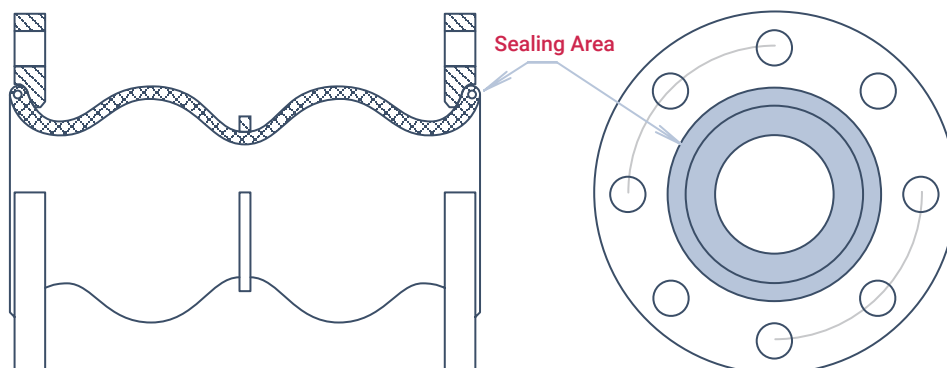

STYLE REJU, REJW AND REJV RUBBER DUCTING JOINTS

Global-Flex Mfg. Style REJU expansion joints are elastomeric in both body and flange and are available in Neoprene, Hypalon, EPDM, Butyl, or fluor-elastomer Viton. Thinner in overall gauge than pressure piping expansion joints to protect thin wall duct systems. Standard circular expansion joints have integral duct and rubber flanges, drilled to order. The rectangular style also incorporates rubber flanges, utilizing square corners and special drilling. "Continuous corners" eliminate splices through the body of the expansion joint near the corners. The inherent flexibility of rubber provides long service life even in applications of high vibration or flutter. Style "REJU", U-joint without arch, designed for normal ducting movements. Metallic backing rings or bars are required. Typical retaining bars are made of 3/8" x 2" A-36 chamfered or rounded edge bar stock. Tube & Cover Neoprene, EPDM, Hypalon, Butyl, or Viton Reinforcement Synthetic fiber reinforcement pressure range 3 PSIG to 5 PSIG depending on number of plies.

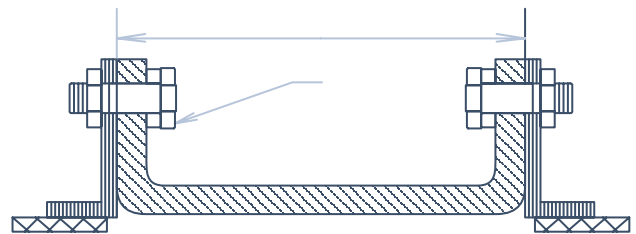
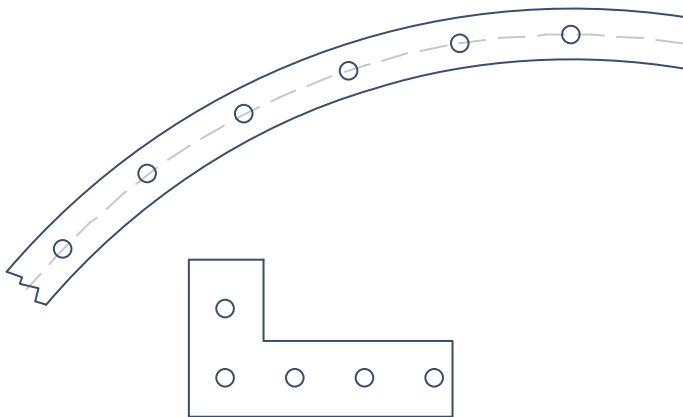

Tube & Cover: EPDM, Hypalon, Butyl, or Viton
Reinforcement: Synthetic fiber reinforcement
Pressure Range: 3 PSIG to 5 PSIG (Depending on number of plies)
Accessories: Recommended Metallic retaining rings or bars
Compression: 2-1/4" to 5" (Depending on size)
Face-To-Face Dimension: 6", 9", 12", or 16"
Temperature Rating: 250°F to 400°F (Depending on elastomer)

Global-Flex Mfg. Style REJW expansion joints are elastomeric in both body and flange and are available in Neoprene, Hypalon, EPDM, Butyl, or flour-elastomer Viton. Thinner in overall gauge than pressure piping expansion joints to protect thin wall duct systems. Standard circular expansion joints have integral duck and rubber flanges, drilled to order. The rectangular style also incorporates rubber flanges, utilizing square corners and special drilling. "Continuous corners" eliminate splices through the body of the expansion joint near the corners. The inherent flexibility of rubber provides long service life even in applications of high vibration or flutter. Style "REJW", a rounded arch type joint, is designed for increased axial movement capabilities without pre-extension or compression metallic backing rings or bars are required. Typical retaining bars are made of 3/8" x 2" A-36 chamfered or rounded edge bar stock.



Tube & Cover: EPDM, Hypalon, Butyl, or Viton
Reinforcement: Synthetic fiber reinforcement
Pressure Range: 3 PSIG to 5 PSIG (Depending on number of plies)
Accessories: Recommended Metallic retaining rings or bars
Compression: 2-1/4" to 5" (Depending on size)
Face-To-Face Dimension: 6", 9", 12", or 16"
Temperature Rating: 250°F to 400°F (Depending on elastomer)

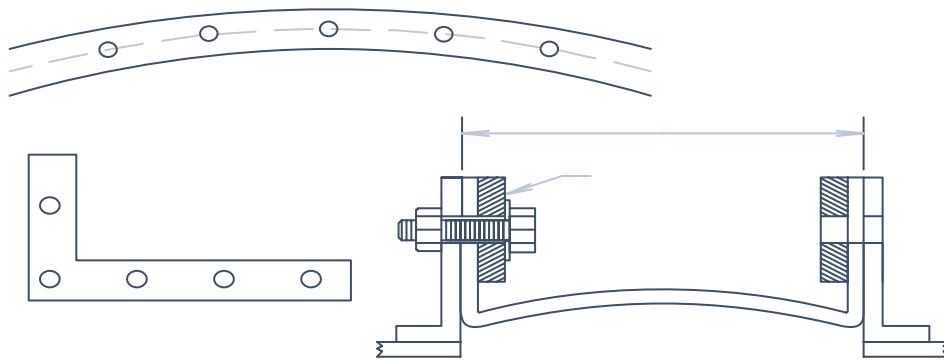

Global-Flex Mfg. Style REJV expansion joints are elastomeric in both body and flange and are available in Neoprene, Hypalon, EPDM, Butyl, or flour-elastomer Viton. Thinner in overall gauge than pressure piping expansion joints to protect thin wall duct systems. Standard circular expansion joints have integral duck and rubber flanges, drilled to order. The rectangular style also incorporates rubber flanges, utilizing square corners and special drilling. "Continuous corners" eliminate splices through the body of the expansion joint near the corners. The inherent flexibility of rubber provides long service life even in applications of high vibration or flutter. Style "REJV", a sharp arch type joint, is designed for large movement capabilities without pre-extension or compression. Metallic backing rings or bars are required. Typical retaining bars are made of 3/8" x 2" A-36 chamfered or rounded edge bar stock.

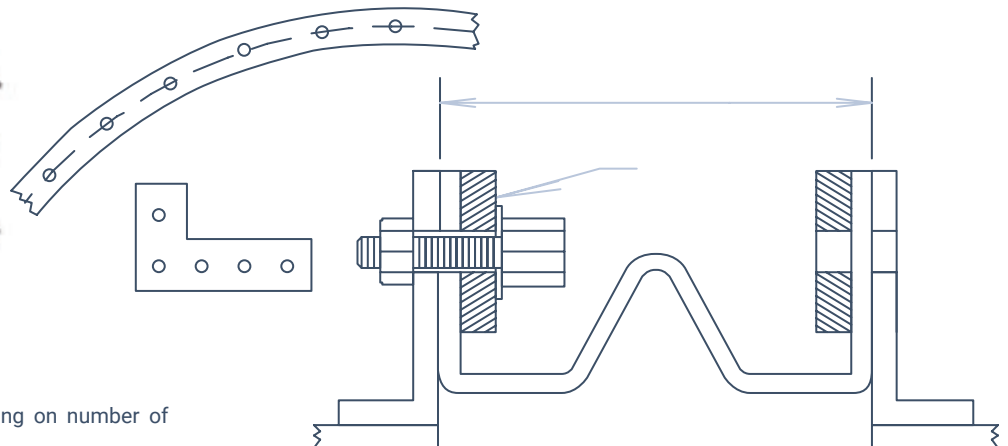

Tube & Cover: EPDM, Hypalon, Butyl, or Viton
Reinforcement: Synthetic fiber reinforcement
Pressure Range: 3 PSIG to 5 PSIG (Depending on number of plies)
Accessories: Recommended Metallic retaining rings or bars
Compression: 2-1/4" to 5" (Depending on size)
Face-To-Face Dimension: 6", 9", 12", or 16"
Temperature Rating: 250°F to 400°F (Depending on elastomer)

STYLE-GFTC FLU-DUCT EXPANSION JOINTS

GFTC Expansion Joints are Non-Metallic Flue Duct Expansion Joints or flexible connectors, which when properly designed, provide stress relief for piping and ducting systems by absorbing thermal growth & shock, isolating mechanical vibration and allowing for misalignments.

Flue duct expansion joints are custom engineered products designed to handle low-pressure (± 5 PSIG) applications with temperatures from -100 F to +2000 deg. F. The expansion joints are manufactured using innovative non-metallic materials and designs.

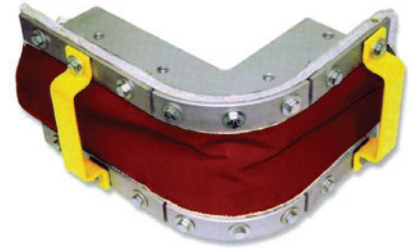

INDUSTRIES AND APPLICATIONS

POWER GENERATION:

Fossil Fired Plants Combined Cycle Plants Industrial Gas Turbines CF Bs (Fluidized Bed Boilers) Nuclear Plants

PULP & PAPER PLANTS:

Chemical Applications Paper Processing Power and Recovery Boilers Fans/Blowers

PETROCHEMICAL:

By product Incineration. Elevated Temperatures (2,000 degrees F) Severe Chemical Attack Refineries

ENVIRONMENTAL APPLICATIONS

SCR & Nox Systems Waste Water Treatment Plants Waste & Recycling Incinerators Stack & Chimney Seals CEMs

HEAVY INDUSTRIAL:

Foundries Steel Mills Cement Plants Aluminum Plants Kilns & Smelters

OTHERS:

HVAC Marine Food Processing HRSG / Co-generation Chemical Processing

DESIGN ADVANTAGES OF NON-METALLIC DUCTING EXPANSION JOINTS

1. Large movement capability | Multi-plane movements.
2. Corrosion | Chemical Resistance
3. Range of Design Temperature Capability(-110 F to +2000 F)
4. Negligible Spring Rates / Loads
5. Vibration Dampening & Sound Attenuation
6. Lower Overall Costs (Design, Installation, Replacement & Repair)
7. Easily Repairable / Installable
8. High Cycle Life
9. Unique Application Solutions

APPLICATIONS

Industrial applications can be separated into general categories based on the media composition (Air or Gas) and temperature. The following section is designed to aid in the selection of the appropriate expansion joint for the specific application range. All plants are different, therefore the service locations and temperatures may vary, This section is only a guide and should be confirmed with a Global-Flex Engineer.

AMBIENT AIR SERVICES (-40 degrees F to 150 degrees F)

Ambient temperature clean air without particulate or chemicals to damage the flexible element. Expansion Joint is used frequently for vibration and sound attenuation from fan equipment.

LOCATIONS: FD Fan Inlet/Outlet Primary Air Fan to Air Heater
 Service Air Intakes Primary Air to Recovery Boiler

An integrally flanged elastomeric joint is suggested. Either Neoprene or EPDM single layer belts are frequently used.

AMBIENT AIR SERVICES (500 degrees F to 800 degrees F)]

Clean air after coming in contact with hot flue gases at the Air Pre-Heater where temperatures are elevated with minimal particulate and/or gas carryover. Expansion joint will see thermal movements and vibration. Elevated temperatures require a composite flexible element and a flow liner.

LOCATIONS: Air Heater Air Outlet Secondary Air
 Over Fire Air Fans Fan Mill Air

A flat composite belt with a bolt or weld-in frame design and flow liner is suggested. The weld-in outboard angle frame design with field welded flow liner is shown.

LOW TO MODERATE TEMPERATURE FLUE GAS

SERVICES (150 degree F to 600 degree F)

Flue gas which has passed through an air pre-heater and dust collector to reduce the temperature and particulate levels. Flue gas may cycle near the dew point where condensation can occur and chemicals are present. Expansion joint may see thermal movements, vibration, and chemical attack.

LOCATIONS: Precip. Outlet Scrubber Inlet / Outlet Re-heater
 I D Fan Inlet/Outlet HRSG Outlet Inlet/Outlet

A single layer belt with chemical barrier is suggested in either integrally flanged or flat belt type. Such as the weld-in outboard angle frame design and Teflon® coated single layer belt with gas film shown.

HOT FLUE GAS SERVICES (600 Degree F to 1200 Degree F)

Flue gas directly after combustion stage at elevated temperatures with possible particulate present. Expansion Joint is used for possible large thermal movements at elevated temperatures.

LOCATIONS: Economizer Outlet Recovery Boiler Outlet
 Cyclone Inlet! Outlet Air Heater Gas Inlet/Outlet
 Precip Inlet Gas Re-circulation System

High temperature composite flat belt style with setback frames, cavity pillow and flow liners is suggested. The standard "Z" frame design with telescoping flow liners or "J" frame design with shop liner are two designs frequently used in these applications.

REJ NOTE PAD

SIZE

TEMPERATURE

APPPLICATION

MEDIUM

PRESSURE

EENDS

DELIVERY

A Required Axial
Compression/Extension

L Required Lateral
Movement

STYLE SC CONNECTORS

ENGINEERING SPECIFICATION GUIDE

Where indicated on the drawings, provide flexible seismic/expansion Connectors of the size, type, and end connection noted on details. Connectors shall be designed and constructed to accommodate motion in all three planes, and to impart no pressure thrust loads on the anchors.

Connectors shall be installed in the neutral length listed on the manufacturer's diagrams, unless otherwise directed by the engineer. Connectors shall be positioned and supported as per manufacturer's installation instructions. The Connectors shall consist of two flexible legs of metallic braided hose, two 45-degree elbows and a 90-degree return elbow. Drains shall be provided in steam applications.

Flexible Connectors shall be rated for a minimum of 150 PSIG working pressure in all sizes. Flanged, weld type, threaded, grooved, or copper tube end connections to be provided to match connecting pipe. Connectors shall be rated for 2, 3, or 4 inches of motion, as indicated on project drawings.

At least one pipe alignment guide should be positioned within four pipe diameters on each side of the loop.



***Special Chevron effect allows for easy nesting of standard products.**

Flexible seismic/expansion Connectors shall be **Global-Flex Seismic Connectors SC-FLG Flanged, SC-GVD Grooved Ends, SC-MPT Male Pipe Tread, SC-B-SWT Sweat Ends.**

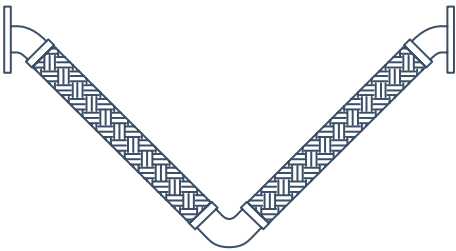
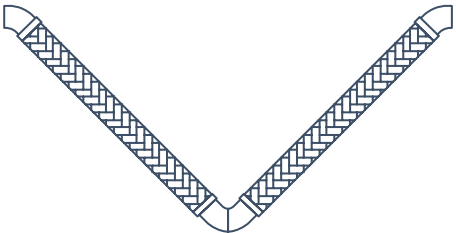
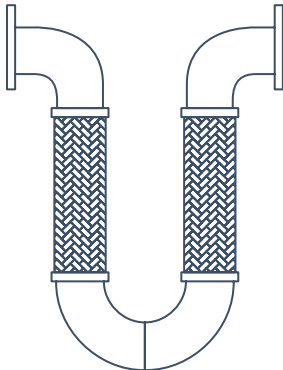
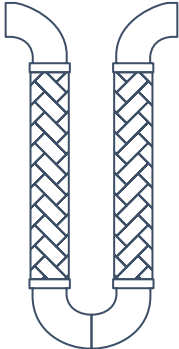

SEISMIC CONNECTORS

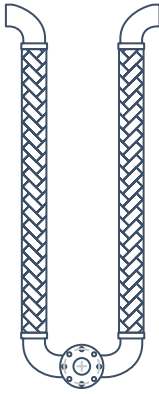
<p>STYLE SC</p>	<p>V OR CHEVRON STYLE SEISMIC CONNECTOR.</p> <ul style="list-style-type: none"> • Stainless Steel Hose and Braid • Designed for movement 2 inches up to 7 inches • End configuration (Carbon Steel or All Stainless Steel) Male Pipe Thread Flanged Weld End Grooved Ends • V or Chevron design allows for easy nesting with no alterations of standard product 	
<p>STYLE SCB</p>	<p>V OR CHEVRON STYLE SEISMIC CONNECTOR.</p> <ul style="list-style-type: none"> • Bronze Hose and Braid • Designed for movement 2 inches up to 7 inches • End configuration (Copper Fittings) Male Pipe Thread Flanged Sweat Ends • V or Chevron design allows for easy nesting with no alterations of standard product 	
<p>STYLE SCU</p>	<p>U STYLE SEISMIC CONNECTOR.</p> <ul style="list-style-type: none"> • Stainless Steel Hose and Braid • Designed for movement 2 inches up to 7 inches • End configuration (Carbon Steel or All Stainless Steel) Male Pipe Thread Flanged Weld End Grooved Ends • U design allows for shorter face to face dimension 	
<p>STYLE SCUB</p>	<p>U STYLE SEISMIC CONNECTOR.</p> <ul style="list-style-type: none"> • Bronze Hose and Braid • Designed for movement 2 inches up to 7 inches • End configuration (Copper Fittings) Male Pipe Thread Flanged Sweat Ends • U design allows for shorter face to face dimension 	

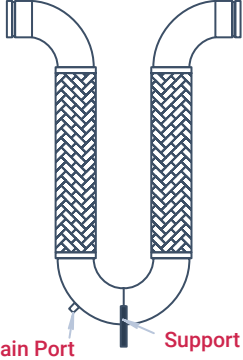
SEISMIC CONNECTORS

<h2>STYLE SCU-SANITARY LOOP</h2>	<p>V OR CHEVRON STYLE SEISMIC CONNECTOR.</p> <ul style="list-style-type: none"> Stainless Steel Hose and Braid Designed for movement 2 inches up to 7 inches End configuration (Carbon Steel or All Stainless Steel) Male Pipe Thread Flanged Weld End Grooved Ends V or Chevron design allows for easy nesting with no alterations of standard product 	
<h2>STYLE FSCU-FIRE SPRINKLER</h2> 	<p>V OR CHEVRON STYLE SEISMIC CONNECTOR.</p> <ul style="list-style-type: none"> Bronze Hose and Braid Designed for movement 2 inches up to 7 inches End configuration (Copper Fittings) Male Pipe Thread Flanged Sweat Ends V or Chevron design allows for easy nesting with no alterations of standard product 	 <p>Drain Port Support Bracket</p>

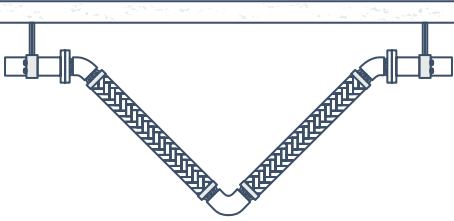
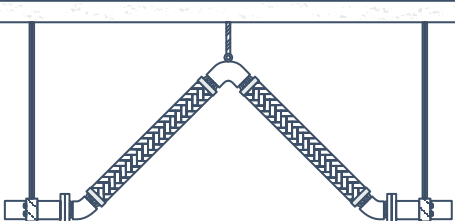
SC& SCU CONNECTORS INSTALLATION INSTRUCTIONS

		
<p>HANGING DOWN</p>	<p>STRAIGHT-UP/HORIZONTAL-RUN</p>	<p>VERTICAL RUN</p>
<p>Horizontal Run- SC & SCU Connectors shall hang straight down and be free to flex. Pipe guides are required to direct movement *Drain port should be used for steam applications * Pipe Guides should be installed at a length of four times diameter of pipe.</p>	<p>Support must be provided to prevent the Seismic connector from leaning, drooping, or torquing the pipe. Support must be loose enough to allow chevron to move at least 1/4 of an inch in all directions. Guides are required to direct movement of pipe in axial plane. For steam applications it is recommended to install in hanging-down or hanging-horizontal position. *Drain ports should be used for steam applications *Pipe Guides should be installed at a length of four times diameter of pipe.</p>	<p>Seismic connectors must be supported to allow the chevron to move horizontally back and forth 1/4" as the connectors flex. Guides are required to direct movement of pipe on axial plane. *Pipe Guides should be installed at a length of four times diameter of pipe. ** Not recommend for steam applications</p>

FSCU-CSGV

Seismic U Connectors For Fire Sprinkler Systems

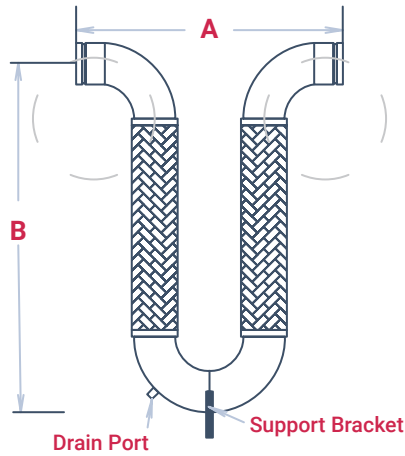

- Hose:** 321 Stainless Steel
- Braid:** 304 Stainless Steel
- End Fittings:** Carbon Steel Grooved Ends
- Long Radius Elbow:** Carbon Steel Schedule 40
- Support Bracket:** Carbon Steel
- Drain Port :** ¾ Carbon Steel Female Pipe Thread

Note: Any seismic loop that is installed in any orientation other than hanging down requires a support bracket. Refer to the installation instructions.



MODEL TYPE	SIZE	MOVEMENT	A END TO END	B LENGTH	PSI	SPRING FORCE LBS	WEIGHT LBS
FSCU200CSGV-4.0MVT	2"(50mm)	+/- 4"	20.56"	28.78"	300	78	19
FSCU250CSGV-4.0MVT	2-1/2" (65mm)	+/- 4"	22.93"	31.01"	300	83	29
FSCU300CSGV-4.0MVT	3" (80mm)	+/- 4"	25.61"	35.75"	300	90	44
FSCU400CSGV-4.0MVT	4" (100mm)	+/- 4"	31.88"	41.24"	175	120	59
FSCU500CSGV-4.0MVT	5" (125mm)	+/- 4"	37.88"	48.81"	175	186	99
FSCU600CSGV-4.0MVT	6" (150mm)	+/- 4"	43.88"	54.30"	175	202	150
FSCU800CSGV-4.0MVT	8" (200mm)	+/- 4"	55.87"	64.78"	175	260	287
FSCU200CSGV-6.0MVT	2"(50mm)	+/- 6"	22.56"	33.65"	300	78	20
FSCU250CSGV-6.0MVT	2-1/2" (65mm)	+/- 6"	25.00"	35.19"	300	83	34
FSCU300CSGV-6.0MVT	3" (80mm)	+/- 6"	26.38"	38.79"	300	90	47
FSCU400CSGV-6.0MVT	4" (100mm)	+/- 6"	31.88"	45.82"	175	120	65
FSCU500CSGV-6.0MVT	5" (125mm)	+/- 6"	37.88"	52.27"	175	186	106
FSCU600CSGV-6.0MVT	6" (150mm)	+/- 6"	43.88"	59.80"	175	202	162
FSCU800CSGV-6.0MVT	8" (200mm)	+/- 6"	55.87"	70.89"	175	260	300
FSCU200CSGV-8.0MVT	2"(50mm)	+/- 8"	24.58"	37.67"	300	78	40
FSCU250CSGV-8.0MVT	2-1/2" (65mm)	+/- 8"	26.93"	39.44"	300	83	65
FSCU300CSGV-8.0MVT	3" (80mm)	+/- 8"	29.05"	43.79"	300	90	90
FSCU400CSGV-8.0MVT	4" (100mm)	+/- 8"	32.91"	50.81"	175	120	122
FSCU500CSGV-8.0MVT	5" (125mm)	+/- 8"	37.88"	57.77"	175	186	202
FSCU600CSGV-8.0MVT	6" (150mm)	+/- 8"	43.88"	64.87"	175	202	293
FSCU800CSGV-8.0MVT	8" (200mm)	+/- 8"	55.87"	77.38"	175	260	500
FSCU200CSGV-24.0MVT	2"(50mm)	+/- 24"	40.56"	47"	300	78	40
FSCU250CSGV-24.0MVT	2-1/2" (65mm)	+/- 24"	42.93"	52.25"	300	83	65
FSCU300CSGV-24.0MVT	3" (80mm)	+/- 24"	44.89"	57.25"	300	90	90
FSCU400CSGV-24.0MVT	4" (100mm)	+/- 24"	48.97"	63.55"	175	120	122
FSCU500CSGV-24.0MVT	5" (125mm)	+/- 24"	53.14"	70.45"	175	186	202
FSCU600CSGV-24.0MVT	6" (150mm)	+/- 24"	57.13"	79.25"	175	202	293
FSCU800CSGV-24.0MVT	8" (200mm)	+/- 24"	65.6"	99.28"	175	260	500

Note: At least one pipe alignment guide should be positioned within four pipe diameters on each side of the loop.

SC CONNECTOR **HANGING-DOWN** Horizontal Run

SC Connectors shall hang straight down and be free to flex. Pipe guides are required to direct movement.

*Drain port should be used for steam applications.

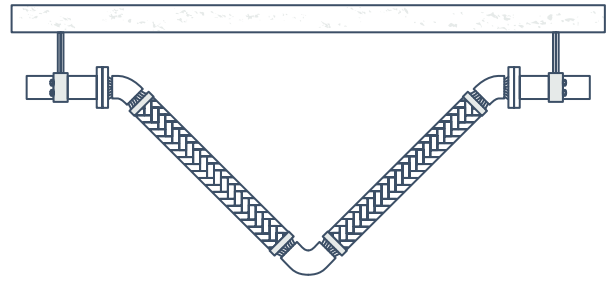

SC CONNECTOR **STRAIGHT-UP/ HORIZONTAL** Horizontal Run

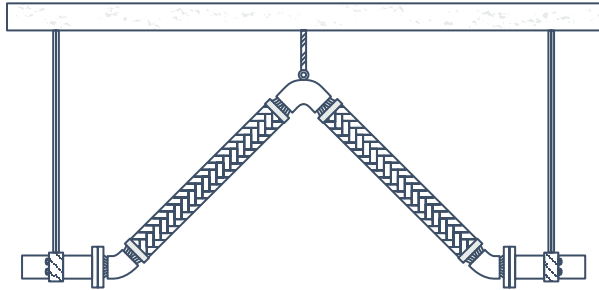

Support must be provided to prevent the Seismic connector from leaning, drooping, or torquing the pipe. Support must be loose enough to allow Chevron to move at least 1/4 of an inch in all directions. Guides are required to direct the movement of the pipe in the axial plane. For steam applications, it is recommended to install in a hanging-down or hanging-horizontal position.

*Drain ports should be used for steam applications.

SC CONNECTOR **Vertical Run**

Seismic connectors must be supported to allow the chevron to move horizontally back and forth 1/4" as the connectors flex. Guides are required to direct movement of pipe on axial plain.

* Not recommend for steam applications.

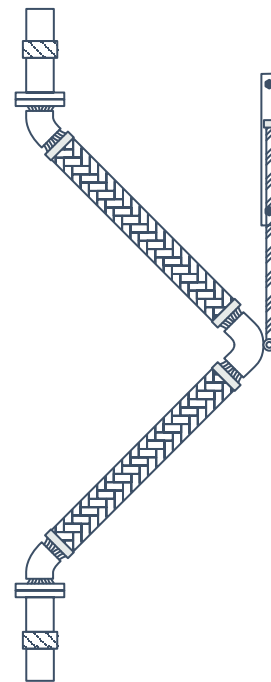

SC CONNECTORS **Nested**

Global-Flex chevron design allows for easy nesting with standard connectors.

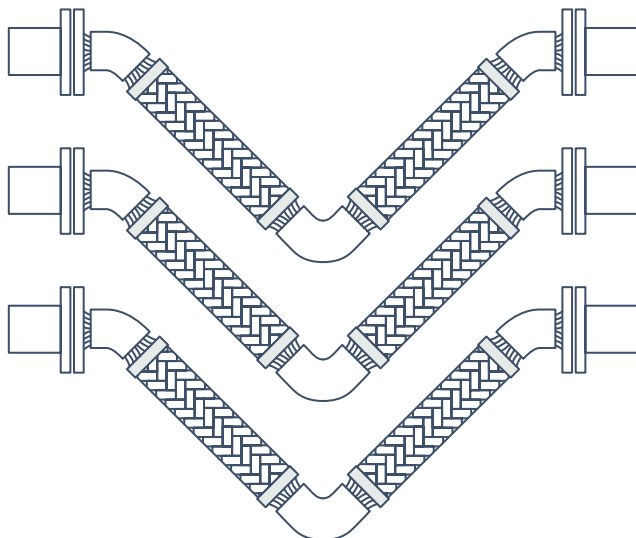

TECHNICAL ASSISTANCE AND SPECIAL DESIGN

- Special design to include large amounts of movement.
- High pressure Special alloys including Monel.
- Standard, Metric and Din drilling.
- Full submittal program.
- Proper installation instructions.
- Fast turn around.

Global  Flex Mfg.

SC/SCB/SCU/SCUB NOTE PAD

SIZE

TEMPERATURE

APPPLICATION

MEDIUM

PRESSURE

EENDS

DELIVERY

STYLE-HP FIRE RETARDANT HEAT PUMP HOSE ASSEMBLY

Global-Flex Mfg. now provides you with superior, Fire Retardant Hose Assemblies of unparalleled quality and integrity, designed specifically for your water source heat pump applications. Our specially coated braid protects the tube from exterior abrasion and prevents rusting. Assemblies are available in any length. Style HP provides you a hose with a long life of trouble-free service.



GLOBAL-FLEX MFG. STYLE HP ADVANTAGES:

- Superior abrasion resistant properties from our coated wire braid.
- The “washer-less” design of the swivel end provides you with ease of installation.
- Superior water flow capabilities, due to excellent flexibility of the hose, which also minimizes the possibility of kinking.
- All male pipe threads are shipped with thread sealant already applied (eliminating the need for Teflon tape), capped and ready for installation.
- Plated steel fittings and adapters reduce the possibility of over-torquing, a common problem with brass and other soft metals.

Specifications	½"	¾"	1"	1-1/4"
Working Pressure	400 psi	300 psi	500 psi	400 psi
Min Burst @ 70 degrees F	1,600 psi	1,200 psi	2,000 psi	1,600 psi
Min Bend Radius	2.5"	4"	5.5"	10"
Hose O.D.	.700	.975	1.245	1.580
Temperature Range	-40/+200 F	40/+200 F	40/+200 F	40/+200 F
Weight Per 100 Foot	18.3 #	24.4"	38.8"	57 #

- Your fire-rated water source applications have never been more secure than now, with HP Fire Retardant Hose Assemblies. Our tube compound is tested to and meets UL-94 with a VO Rating, the highest standard in the industry. The patented process, which bonds the tube to a stainless steel wire outer braid, minimizes the possibility of the hose assembly kinking during installation.

STYLE-SSHPEP ALL STAINLESS STEEL HEAT PUMP HOSE ASSEMBLY

Global-Flex Mfg. now provides you with superior, extremely flexible, all stainless steel corrugated hose covered by stainless steel braid. Assembly is engineered to last the life of the mechanical system, handling greater offsets and higher temperatures without compromising hose integrity. Assemblies are available in any length. *Style SSHPEP provides* you a hose with a long life of trouble-free service Meets buy America Act.

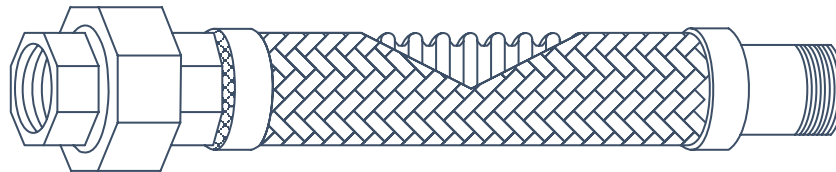

GLOBAL-FLEX MFG. STYLE SSHPEP ADVANTAGES:

- Extremely flexible
- Extremely durable
- Last the life of mechanical system
- Handles greater offsets
- Stainless steel ends fittings standard
- Good for cold water, hot water, and steam
- Higher PSI
- Good for temperature up to 1,000 F
- No gaskets
- Vibration isolation

Specifications	.50	.75	1.0	1.25	1.50
Working Pressure	1,225 psi	1,034 psi	796 psi	600 psi	557 psi
Min Burst @ 70 F	4,900 psi	4,136 psi	3,184 psi	2,400 psi	2,228 psi
Min Bend Radius	1.75"	2.65"	3.33"	4.10"	5.08"
Temperature Range	-100/+1,000 F	-100/+1,000 F	-100/+1,000 F	-100/+1,000 F	-100/+1,000 F

APPLICATIONS

- Fan Coil Hook Up
- Heat Pump
- Isolates Pump Vibration
- Steam
- Steam Condensate
- Seismic

STYLE 712

TEFLON EXPANSION JOINT

Global-Flex Mfg. Convolute Teflon bellows expansion joints and flexible couplers offer the best combination of low spring-rate flexibility and the chemical inert properties of PTFE material. Style 712 convolute flexible coupling joint is designed to meet the needs of the high-technology, chemical-petrochemical, power generation, pulp and paper, and other demanding industry needs. Teflon bellows connectors are versatile and will 1) absorb pipe movements and stress; 2) isolate mechanical vibration; 3) reduce system noise; 4) protect against surge forces.

The construction of the connector utilizes molded convolutions of white PTFE. These convolutions are reinforced with metallic rings between the bellows for pressure rating and stability. The metal backing flanges are protected by the lip of the Teflon bellows, so that all wetted surfaces are Teflon. Steel limit rods are factory installed. Additional convolutions provide greater movement capability. Options include Type 316 stainless steel backing flanges and hardware, white epoxy coated flanges, and high-purity cleaning and packaging. 700 series expansion joints can also be manufactured in a machined, accordion style.

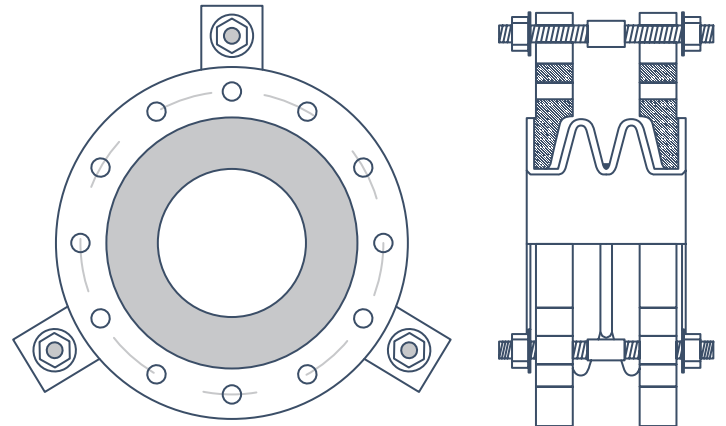

Ideal for plastic piping systems

FEATURES

- Chlorine Resistance
- Anti-stick properties
- Noise and Vibration dampening
- High Flexibility
- Thermal Stability
- Resistance to age cracking
- High pressure ratings
- Temperature rating up to 400 F

I.D.	Face/ Face Inch	Flange O.D.	Bolt Cir Dia.	No of Bolt Holes	Bolt Hose Dia.	Movements		Misalignment Max Degree	Weight
						Compression	Extension		
2	1.57	6	4.75	4	.75	1.75	2.25	19	5.28
2-1/2	1.97	7	5.5	4	.75	2.125	2.78	21	9.77
3	2.20	7.5	6.0	4	.75	2.125	2.78	17	10.69
4	2.36	9	7.5	8	.75	2.50	3.50	14	18.74
5	2.76	10	8.5	8	.875	2.50	3.50	11	26.18
6	2.99	11	9.5	8	.875	2.50	3.50	10	29.22
8	2.99	13.5	11.75	8	.875	2.50	3.50	7	38.32
10	3.27	16	14.25	12	1	3.125	4.375	7	57.60
12	3.86	19	17	12	1	3.125	4.375	6	92.58

For high-purity water and other high-purity applications, specify Class 100 cleaning and packaging. Type 316 stainless steel or white epoxy coated hardware should be considered in these applications.

STYLE 713

TEFLON EXPANSION JOINT

Global-Flex Mfg. *Convolute Teflon bellows expansion joints and flexible couplers offer the best combination of low spring-rate flexibility and the chemical inert properties of PTFE material. Style 713 convolute expansion joint is designed to meet the needs of the high-technology, chemical-petrochemical, power generation, pulp and paper, and other demanding industry needs. Teflon bellows connectors are versatile and will 1) absorb pipe movements and stress; 2) isolate mechanical vibration; 3) reduce system noise; 4) protect against surge forces.*

The construction of the connector utilizes molded convolutions of white PTFE. These convolutions are reinforced with metallic rings between the bellows for pressure rating and stability. The metal backing flanges are protected by the lip of the Teflon bellows, so that all wetted surfaces are Teflon. Steel limit rods are factory installed. Additional convolutions provide greater movement capability. Options include Type 316 stainless steel backing flanges and hardware, white epoxy coated flanges, and high-purity cleaning and packaging. 700 series expansion joints can also be manufactured in a machined, accordion style.

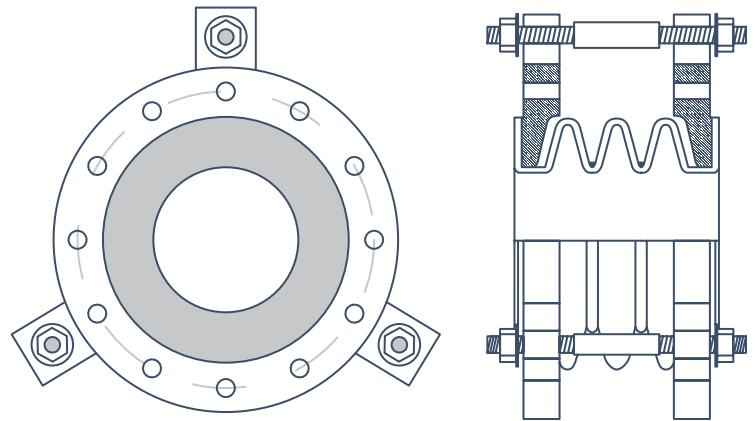
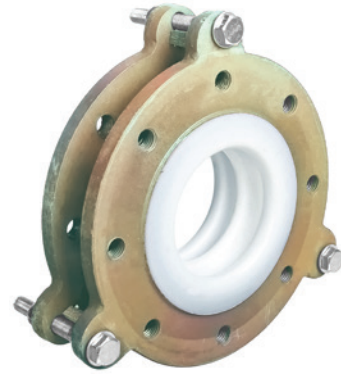

FEATURES

- Chlorine Resistance
- Anti-stick properties
- Noise and Vibration dampening
- High Flexibility
- Thermal Stability
- Resistance to age cracking
- High pressure ratings
- Temperature rating up to 400° F

I.D.	Face/ Face Inch	Flange O.D.	Bolt Cir Dia.	No of Bolt Holes	Bolt Hose Dia.	Movements		Misalignment Max Degree	Weight
						Compression	Extension		
2	2.28	6	4.75	4	.75	2.75	3.75	28	5.28
2-1/2	2.50	7	5.5	4	.75	2.75	3.75	22	9.77
3	2.90	7.5	6.0	4	.75	2.75	3.75	20	10.87
4	3.23	9	7.5	8	.75	3.25	4.75	20	19.65
5	3.70	10	8.5	8	.875	3.25	4.75	12	27.04
6	4.09	11	9.5	8	.875	3.25	4.75	14	30.32
8	4.09	13.5	11.75	8	.875	3.25	4.75	14	39.42
10	4.37	16	14.25	12	1	4.0	6.0	12	60.90
12	5.31	19	17	12	1	4.0	6.0	10	94.78

For high-purity water and other high-purity applications, specify Class 100 cleaning and packaging. Type 316 stainless steel or white epoxy coated hardware should be considered in these applications.

STYLE 715 - DOM TEFLON EXPANSION JOINT

Global-Flex Mfg. *Convolute Teflon bellows expansion joints and flexible couplers offer the best combination of low spring-rate flexibility and the chemical inert properties of PTFE material. Style 715 convolute expansion joint is designed to meet the needs of the high-technology, chemical-petrochemical, power generation, pulp and paper, and other demanding industry needs. Teflon bellows connectors are versatile and will 1) absorb pipe movements and stress; 2) isolate mechanical vibration; 3) reduce system noise; 4) protect against surge forces.*

The construction of the connector utilizes molded convolutions of white PTFE. These convolutions are reinforced with metallic rings between the bellows for pressure rating and stability. The metal backing flanges are protected by the lip of the Teflon bellows, so that all wetted surfaces are Teflon. Steel limit rods are factory installed. Additional convolutions provide greater movement capability. Options include Type 316 stainless steel backing flanges and hardware, white epoxy coated flanges, and high-purity cleaning and packaging. 700 series expansion joints can also be manufactured in a machined, accordion style.

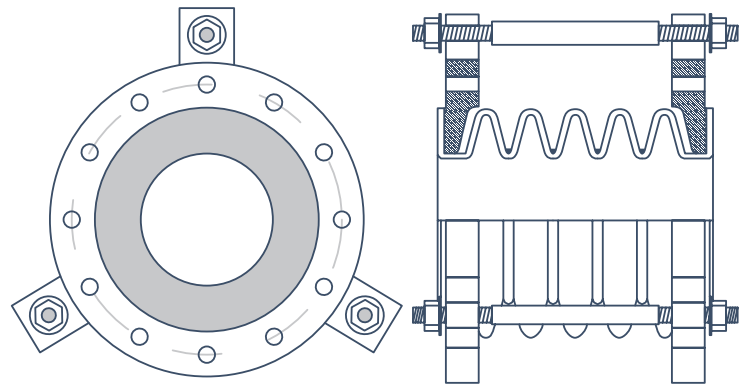

FEATURES

- Chlorine Resistance
- Anti-stick properties
- Noise and Vibration dampening
- High Flexibility
- Thermal Stability
- Resistance to age cracking
- High pressure ratings
- Temperature rating up to 400° F

I.D.	Face/ Face Inch	Flange O.D.	Bolt Cir Dia.	No of Bolt Holes	Bolt Hose Dia.	Movements		Misalignment Max Degree	Weight
						Compression	Extension		
2	3.35	6	4.75	4	.75	2.75	3.75	28	5.72
2-1/2	4.09	7	5.5	4	.75	2.75	3.75	22	10.30
3	4.33	7.5	6.0	4	.75	2.75	3.75	20	12.19
4	4.92	9	7.5	8	.75	3.25	4.75	20	20.72
5	5.59	10	8.5	8	.875	3.25	4.75	12	28.25
6	6.30	11	9.5	8	.875	3.25	4.75	14	32.52
8	6.30	13.5	11.75	8	.875	3.25	4.75	14	42.72
10	6.57	16	14.25	12	1	4.0	6.0	12	64.20
12	8.23	19	17	12	1	4.0	6.0	10	98.09

For high-purity water and other high-purity applications, specify Class 100 cleaning and packaging. Type 316 stainless steel or white epoxy coated hardware should be considered in these applications.

Global  Flex Mfg.

HVAC PUMP CONNECTORS NOTE PAD

SIZE

TEMPERATURE

APPPLICATION







MEDIUM

PRESSURE

ENDS

DELIVERY

STYLE 715 - DOM TEFLON EXPANSION JOINT

	<p>RSN, RSE, RDN, RDE, RUN Rubber Spheres, Neoprene, EPDM , Single and Double Arch, Triple Arch Union Ends</p>
	<p>REJM Molded Rubber Expansion Joint L- Shape Backing Rings</p> <p>CR Control Rods</p>
	<p>PM , PML, PF, PFL, PG, PGF SNR Stainless Steel Braided with Carbon Steel Flange, Carbon Steel Male Pipe Thread, Carbon Steel Grooved Ends, Carbon Steel Grooved x Flanged Ends (Reducing Style)</p>
	<p>BS, SB, BM, BV Bronze Braided Copper Sweat, Stainless Steel Braided Copper Sweat. Bronze Braided Copper MPT ,Vibration Absorbers Bronze Braided Copper Sweat</p>
	<p>PB, PB-R 321 Stainless Steel Bellows, Carbon Steel Flange, Carbon Steel Tie Rods</p>
	<p>CM, CMS Compensator Carbon Steel Male Pipe Thread, Compensator Copper Sweat Ends</p>

STYLE # RSN

Single Sphere Rubber Expansion Joint Neoprene

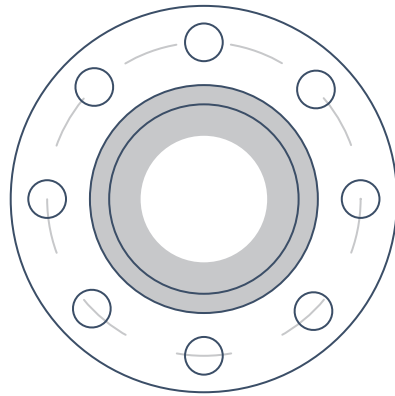
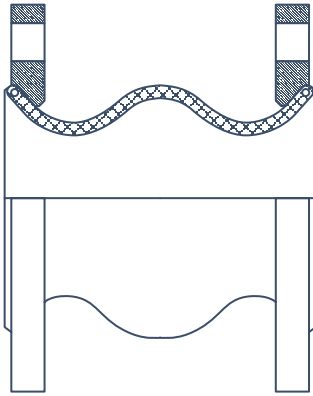

CROSS REFERENCE

Mason
MFNC
Metraflex
Metrasphere Style R

Proco
240-AV/NN
Unisource
U-301

Part-Number	Size Inches
RSN-150	1-1/2" x 6"
RSN-200	2" x 6"
RSN-250	2-1/2" x 6"
RSN-300	3" x 6"
RSN-400	4" x 6"
RSN-500	5" x 6"
RSN-600	6" x 6"
RSN-800	8" x 6"
RSN-1000	10" x 8"
RSN-1200	12" x 8"
RSN-1400	14" x 8"
RSN-1600	16" x 8"
RSN-1800	18" x 8"
RSN-2000	20" x 8"
RSN-2400	24" X8"

STYLE # RSE

Single Sphere Rubber Expansion Joint EPDM

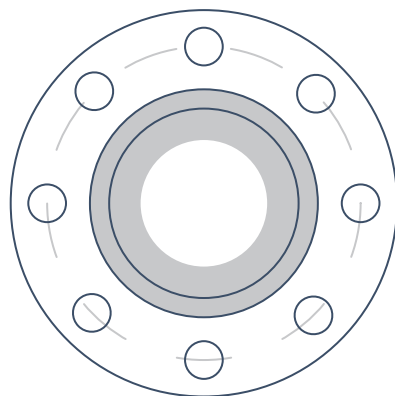
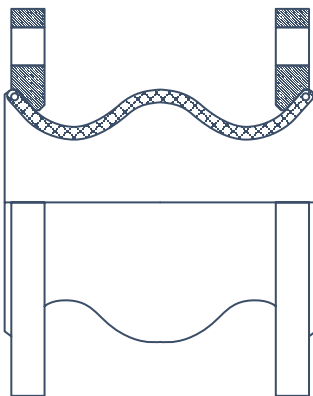

CROSS REFERENCE

Mason
MFNC
Metraflex
Metrasphere Style R

Proco
240-AV/NN
Unisource
U-301

Part-Number	Size Inches
RSE-150	1-1/2" x 6"
RSE-200	2" x 6"
RSE-250	2-1/2" x 6"
RSE-300	3" x 6"
RSE-400	4" x 6"
RSE-500	5" x 6"
RSE-600	6" x 6"
RSE-800	8" x 6"
RSE-1000	10" x 8"
RSE-1200	12" x 8"
RSE-1400	14" x 8"
RSE-1600	16" x 8"
RSE-1800	18" x 8"
RSE-2000	20" x 8"
RSE-2400	24" X8"

STYLE # RDN

Dual Sphere Rubber Expansion Joint Neoprene

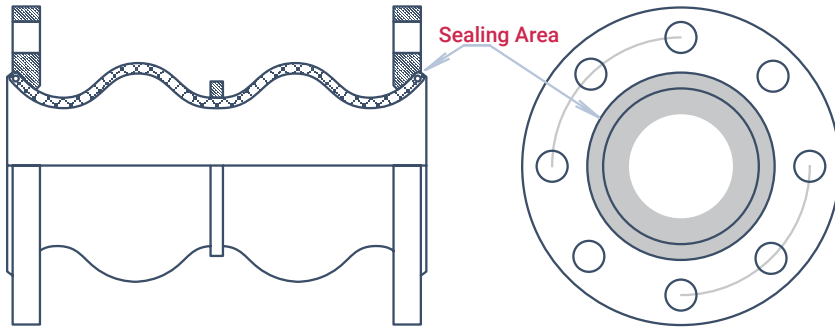

Part-Number	Size Inches
RDN-150	1-1/2" X 7"
RDN-200	2" X 7"
RDN-250	2-1/2" X 7"
RDN-300	3" X 7"
RDN-400	4" X 9"
RDN-500	5" X 9"
RDN-600	6" X 9"
RDN-800	8" X 13"
RDN-1000	10" X 13"
RDN-1200	12" X 13"
RDN-1400	14" X
RDN-1600	16" X
RDN-1800	18" X
RDN-2000	20" X
RDN-2400	24" X

CROSS REFERENCE

Mason
MFTNC
Metraflex
Twin sphere

Proco
242-EE
Unisource
U-302

STYLE # RDE

Dual Sphere Rubber Expansion Joint EPDM

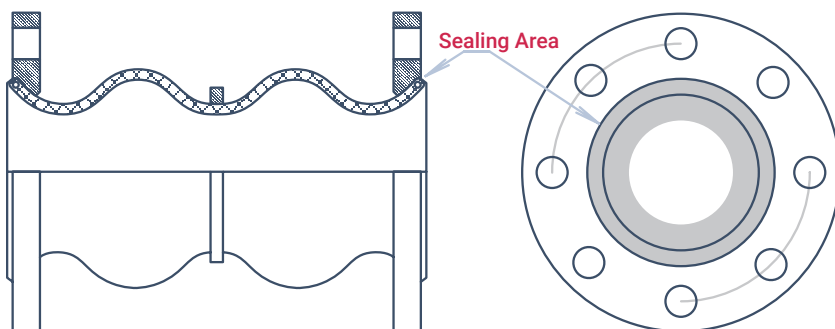

Part-Number	Size Inches
RDE-150	1-1/2" X 7"
RDE-200	2" X 7"
RDE-250	2-1/2" X 7"
RDE-300	3" X 7"
RDE-400	4" X 9"
RDE-500	5" X 9"
RDE-600	6" X 9"
RDE-800	8" X 13"
RDE-1000	10" X 13"
RDE-1200	12" X 13"
RDE-1400	14" X
RDE-1600	16" X
RDE-1800	18" X
RDE-2000	20" X
RDE-2400	24" X

CROSS REFERENCE

Mason
MFTNC
Metraflex
Twin sphere

Proco
242-EE
Unisource
U-302

STYLE # RUSN

Double Union Connector Neoprene

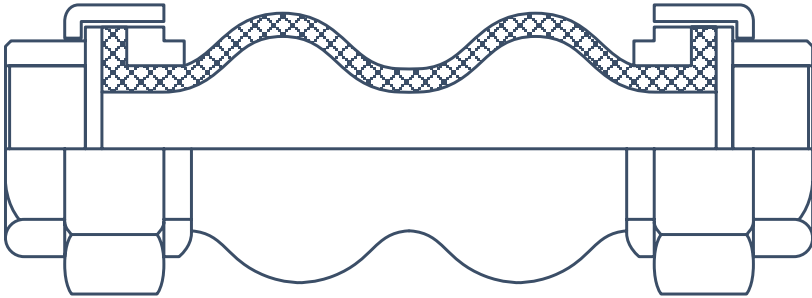

Part-Number	Size Inches
UN-075	3/4" X 8"
UN-100	1" X 8"
UN-125	1-1/4" X 8"
UN-150	1-1/2" X 8"
UN-200	2" X 8"
UN-250	2-1/2" X 8"
UN-300	3" X 8"

CROSS REFERENCE

Mason
MFTFU
Metraflex
Double Sphere Union

Proco
315-A/NN
Unisource
U-303

STYLE # REJM

Molded Rubber Expansion Joint L-Shape Back Up Rings

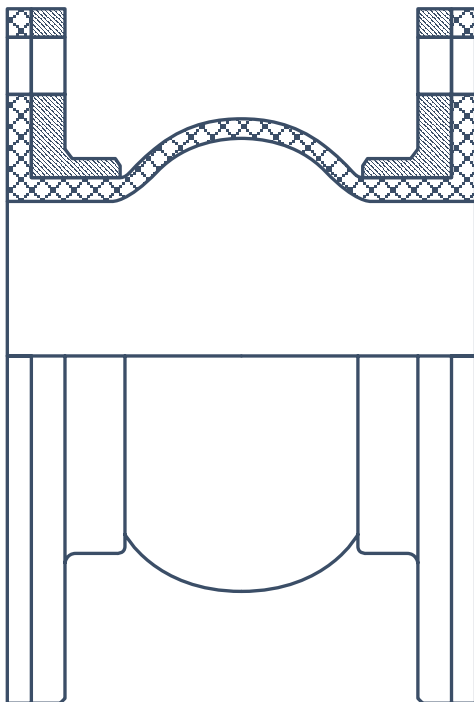

Part-Number	Size Inches
REJM200BB-6.0	2" x 6"
REJM250BB-6.0	2-1/2" x 6"
REJM300BB-6.0	3" x 6"
REJM400BB-6.0	4" x 6"
REJM500BB-6.0	5" x 6"
REJM600BB-6.0	6" x 6"
REJM800BB-6.0	8" x 6"
REJM1000BB-8.0	10" x 8"
REJM1200BB-8.0	12" x 8"

STYLE # CR

Control Rods

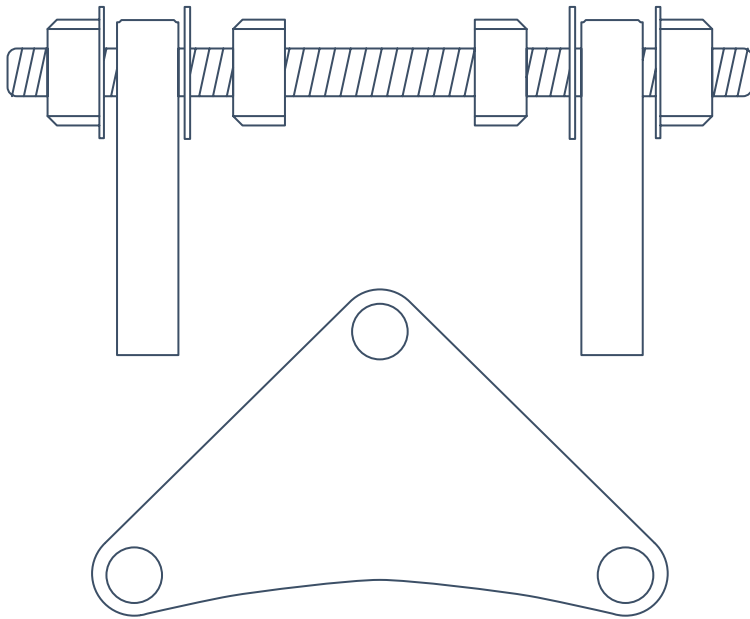

Part-Number	Size Inches
CR-150-CS	1-1/2" X 6"
CR-200-CS	2" X 6"
CR-250-CS	2-1/2" X 6"
CR-300-CS	3" X 6"
CR-400-CS	4" X 6"
CR-500-CS	5" X 6"
CR-600-CS	6" X 6"
CR-800-CS	8" X 6"
CR-1000-CS	10" X 8"
CR-1200-CS	12" X 8"
CR-1400-CS	14" X 8"
CR-1600-CS	16" X 8"
CR-1800-CS	18" X 8"
CR-2000-CS	20" X 8"
CR-2400-CS	24" X 8"

CONTROL UNIT				NOMINAL PIPE SIZE EXP JT ID INCH	MAXIMUM SURGE OR TEST PRESSURE OF THE SYSTEM				
PLATE THICKNESS INCHES	ROD DIAMETER INCHES	STANDARD CONTROL UNITS ASSEMBLY OF:			NUMBER OF CONTROL RODS RECOMMENDED				
		RODS	PLATES		2	3	4	6	8
.375	.500	2	4	.50	1328	--	--	--	--
.375	.500	2	4	.75	1106	--	--	--	--
.375	.500	2	4	1.0	949	--	--	--	--
.375	.500	2	4	1.25	830	--	--	--	--
.375	.500	2	4	1.50	510	--	--	--	--
.375	.625	2	4	2	661	--	--	--	--
.375	.625	2	4	2.5	529	--	--	--	--
.375	.625	2	4	3	441	--	--	--	--
.375	.625	2	4	3.5	365	547	729	--	--
.375	.625	2	4	4	311	467	622	--	--
.375	.625	2	4	5	235	353	470	--	--
.500	.625	2	4	6	186	278	371	--	--
.500	.750	2	4	8	163	244	329	--	--
.750	.875	2	4	10	163	144	325	488	--
.750	1.00	2	4	12	160	240	320	481	--
.750	1.00	2	4	14	112	167	223	335	--
.750	1.125	2	4	16	113	170	227	340	453
.750	1.125	2	4	18	94	141	187	281	375
.750	1.125	2	4	20	79	118	158	236	315
1.00	1.250	2	4	22	85	128	171	256	342
1.00	1.250	2	4	24	74	110	147	221	294

STYLE # PM

Stainless Steel Pump Connectors Carbon Steel MPT

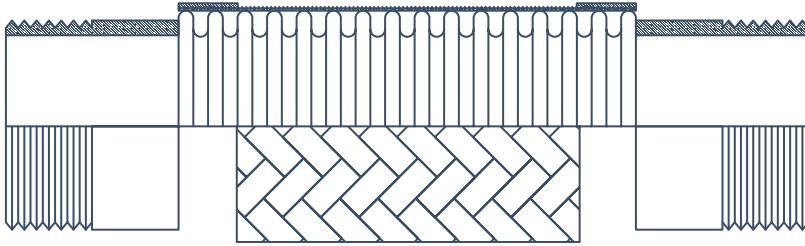

Part-Number	Size Inches
PM-050	1/2" X 6-1/2"
PM-075	3/4" X 7"
PM-100	1" X 8"
PM-125	1-1/4" X 8 1/2"
PM-150	1-1/2" X 9"
PM-200	2" X 10-1/2"
PM-250	2-1/2" X 12"
PM-300	3" X 14"
PM-400	4" X 16"

CROSS REFERENCE

Mason/Mercer
Style BSS PC-MN
Flex Metal Hose
MFC Series

Unisource
UPCS-MMT
Senior Flexonics
PCS-MMT

STYLE # PM-L

Stainless Steel Pump Connectors Carbon Steel MPT Long Length

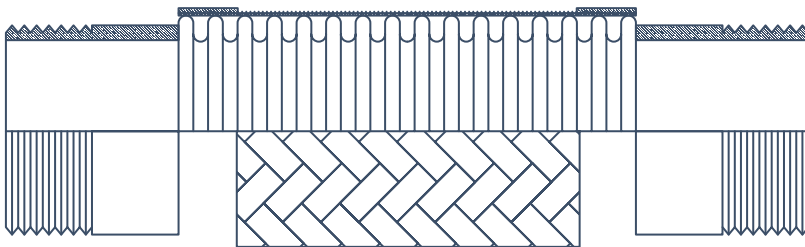

Part-Number	Size Inches
PML-050	1/2" X 10"
PML-075	3/4" X 11"
PML-100	1" X 12"
PML-125	1-1/4" X 13"
PML-150	1-1/2" X 14"
PML-200	2" X 15"

CROSS REFERENCE

Mason/Mercer
Style BSS PC-MN-L
Flex Metal Hose

MFC-L Series
Unisource
UPCS-MMT-L

STYLE # PF

Stainless Steel Pump Connectors Carbon Steel 150 LB Flange

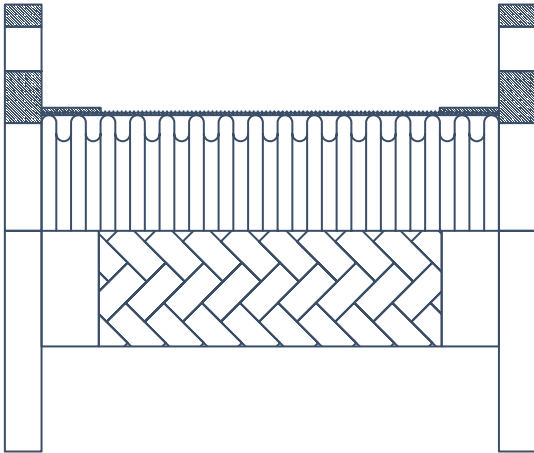

Part-Number	Size Inches
PF-150	1-1/2" X 9"
PF-200	2" X 9"
PF-250	2-1/2" X 9"
PF-300	3" X 9"
PF-400	4" X 9"
PF-500	5" X 11"
PF-600	6" X 11"
PF-800	8" X 12"
PF-1000	10" X 13"
PF-1200	12" X 14"

CROSS REFERENCE

Mason
 Style BSS PC-RF-150
 Metraflex
 Metra Mini

Senior Flexonics
 PCS-FLG
 Unisource
 UPCS-FLG

STYLE # PF-L

Stainless Steel Pump Connectors Carbon Steel 150 LB Flange Long Length

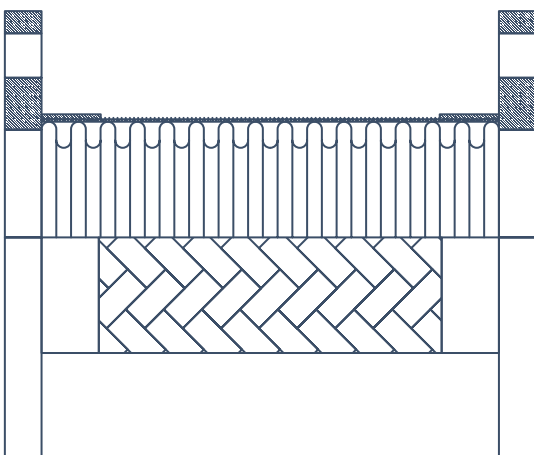

Part-Number	Size Inches
PF-200-L	2" X 12"
PF-250-L	2-1/2" X 12"
PF-300-L	3" X 12"
PF-400-L	4" X 12"
PF-500-L	5" X 18"
PF-600-L	6" X 18"
PF-800-L	8" X 22"
PF-1000-L	10" X 22"

STYLE # PG

Stainless Steel Pump Connectors Carbon Steel Grooved End

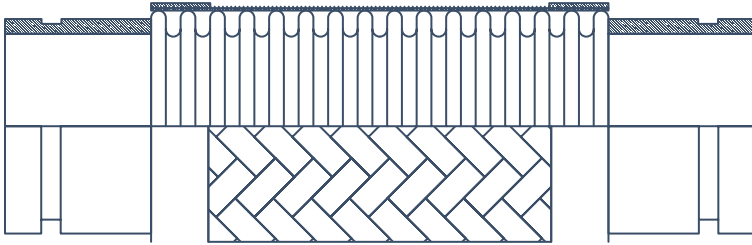

Part-Number	Size Inches
PG-200	2" X 12"
PG-250	2-1/2" X 14"
PG-300	3" X 14"
PG-400	4" X 15"
PG-500	5" X 16"
PG-600	6" X 16"
PG-800	8" X 17"
PG-1000	10" X 18"
PG-1200	12" X 19"

CROSS REFERENCE

Metraflex
Style GG

Unisource
UPCS-GG

STYLE # PGF

Stainless Steel Pump Connectors Carbon Steel 150 LB. Flange X Grv

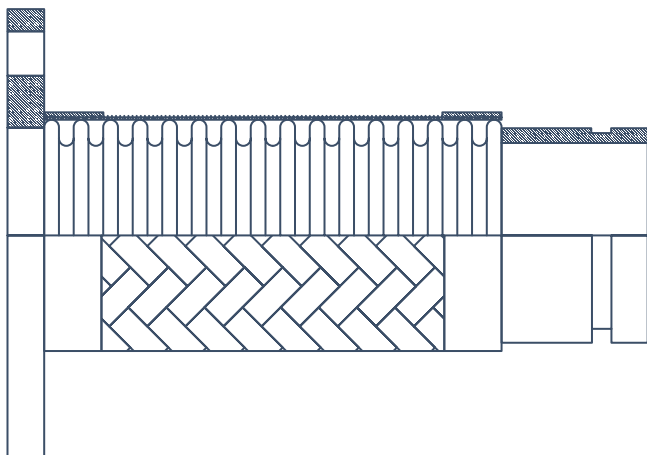

Part-Number	Size Inches
PGF-200	2" X 12"
PGF-250	2-1/2" X 12"
PGF-300	3" X 13"
PGF-400	4" X 13"
PGF-500	5" X 14"
PGF-600	6" X 14"
PGF-800	8" X 15"
PGF-1000	10" X 16"
PGF-1200	12" X 17"

CROSS REFERENCE

Metraflex
Style GF

Unisource
UPCS-GF

STYLE # SNR

Stainless Steel Hose Assembly Carbon Steel Reducer Flanged

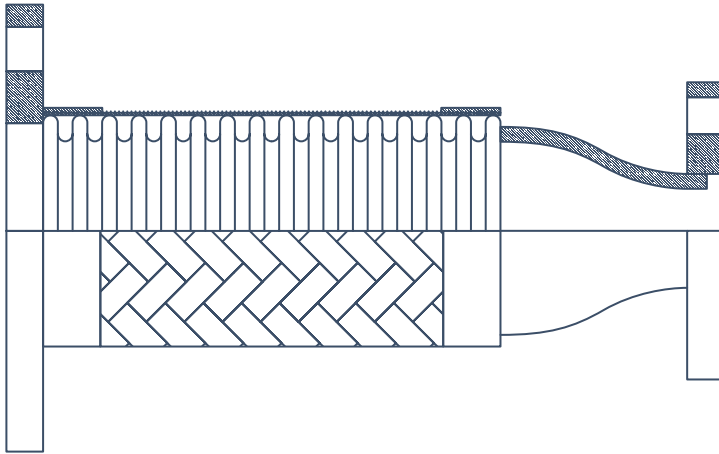

Part-Number	Size Inches
SNR-250200	2-1/2" x 2" x 13"
SNR-300200	3" x 2" x 13"
SNR-300250	3" x 2-1/2" x 13"
SNR-400200	4" x 2" x 13"
SNR-400250	4" x 2-1/2" x 13"
SNR-400300	4" x 3" x 13"
SNR-500250	5" x 2-1/2" x 16"
SNR-500300	5" x 3" x 16"
SNR-500400	5" x 4" x 16"
SNR-600300	6" x 3" x 17"
SNR-600400	6" x 4" x 17"
SNR-600500	6 x 5" x 17"
SNR-800400	8 x 4" x 18"
SNR-800500	8" x 5" x 18"
SNR-800600	8" x 6" x 18"
SNR-1000600	10" x 6" x 18"
SNR-100800	10" x 8" x 18"
SNR-12001000	12" x 10" x 20"

CROSS REFERENCE

Unisource

CRCPS

**Available in Longer Lengths and with Eccentric Reducer. Call Global-Flex for pricing information.*

STYLE # BS

Bronze Pump Connector Sweat Ends

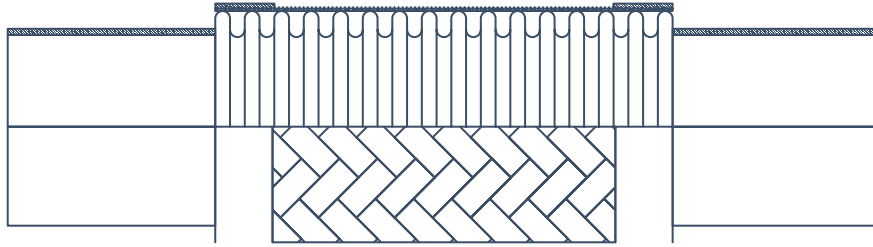

CROSS REFERENCE

Metraflex
Style GG

Unisource
UPCS-GG

Part-Number	Size Inches
BS-050	1/2" X 6-1/2"
BS-075	3/4" X 7"
BS-100	1" X 8"
BS-125	1-1/4" X 8-1/2"
BS-150	1-1/2" X 9"
BS-200	2" X 10-1/2"
BS-250	2-1/2" X 12"
BS-300	3" X 12"

STYLE # SB

Stainless Steel Hose Pump Connector Bronze Sweat Ends

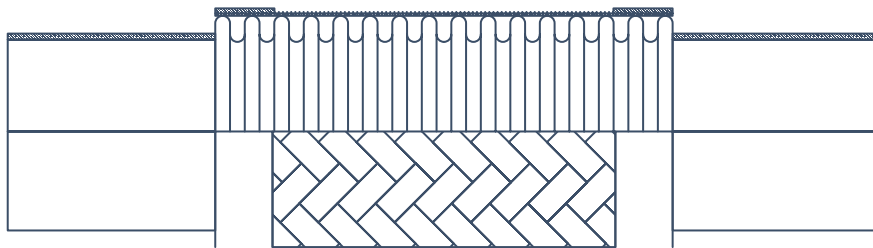

CROSS REFERENCE

Metraflex
Style GF

Unisource
UPCS-GF

Part-Number	Size Inches
SB-050	1/2" X 6-1/2"
SB-075	3/4" X 7"
SB-100	1" X 8"
SB-125	1-1/4" X 8-1/2"
SB-150	1-1/2" X 9"
SB-200	2" X 10-1/2"
SB-250	2-1/2" X 12"
SB-300	3" X 12"

STYLE # BM

Dual Sphere Rubber Expansion Joint Neoprene

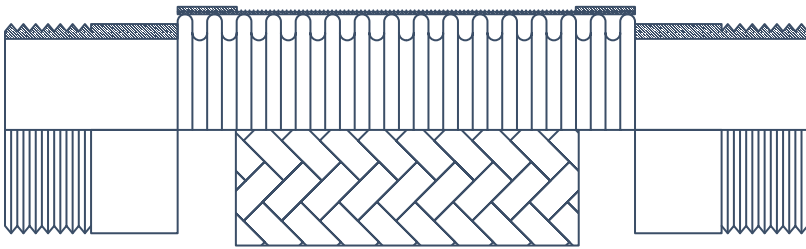

Part-Number	Size Inches
BM-050	1/2" X 6-1/2"
BM-075	3/4" X 7"
BM-100	1" X 8"
BM-125	1-1/4" X 8-1/2"
BM-150	1-1/2" X 9"
BM-200	2" X 10-1/2"
BM-250	2-1/2" X 12"
BM-300	3" X 12"

CROSS REFERENCE

Mason	Senior Flexonics
BBF	PCB-BRMT
Metraflex	Unisource
Style BBT	UPCB-BRMP

STYLE # BV

Bronze Vib – Female Copper Sweat Each End

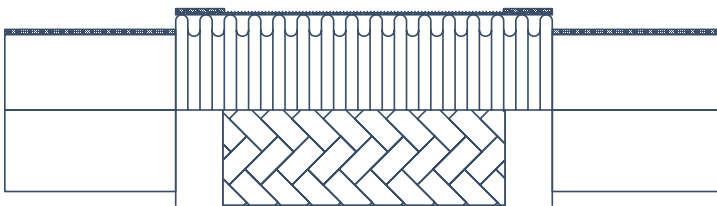

Part-Number	Size Inches
BV-2	1/4 X 7-1/2 to fit 1/4 OD tube
BV-3	3/8 X 8-1/4 to fit 3/8 OD tube
BV-4	3/8 X 9 to fit 1/2 OD tube
BV-5	1/2 X 9-3/4 to fit 5/8 OD tube
BV-6	1/2 X 10 to fit 3/4 OD tube
BV-7	3/4 X 11-1/4 to fit 3/4 OD tube
BV-8	3/4 X 11-1/2 to fit 7/8 OD tube
BV-9	1 X 13 to fit 1-1/8 OD tube
BV-10	1-1/4 X 14-3/4 to fit 1-3/8 OD tube
BV-11	1-1/2 X 17 to fit 1-5/8 OD tube
BV-12	2 X 20 to fit 2-1/8 OD tube
BV-13	2-1/2 X 24 to fit 2-5/8 OD tube
BV-14	3 X 27 to fit 3-1/3 OD tube
BV-15	3-1/2 X 32 to fit 3-5/8 OD tube
BV-16	4 X 33 to 4-1/8 OD tube

CROSS REFERENCE

Mason	Proco
MFTNC	242-EE
Metraflex	Unisource
Twin sphere	U-302

STYLE # PB

Multi Ply Bellows Pump Connectors Flange and Tie Rods

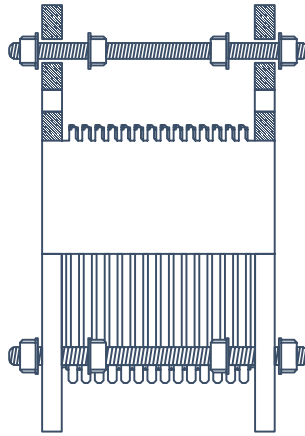
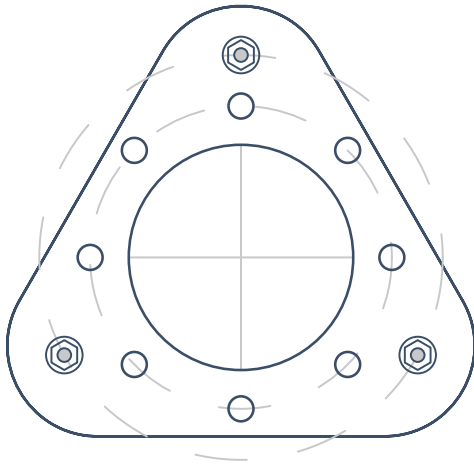

Part-Number	Size Inches
PB-200	2 X 4-3/8 FF
PB-250	2-1/2 X 4-3/8 FF
PB-300	3 X 4-2/8 FF
PB-400	4 X 4-5/8 FF
PB-500	5 X 4-7/8 FF
PB-600	6 X 5 FF
PB-800	8 X 5-7/8 FF
PB-1000	10 X 6-5/8 FF
PB-1200	12 X 6-5/8 FF

CROSS REFERENCE

Hyspan
Series 5500
Microflex
Style MBS

Senior Flexonics
Series TCS
Unisource
BPC

STYLE # PB-R

Multi Ply Bellows Pump Connectors Flange and Tie Rods

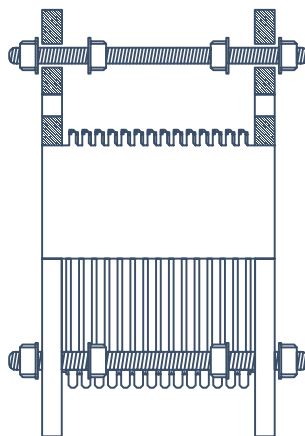
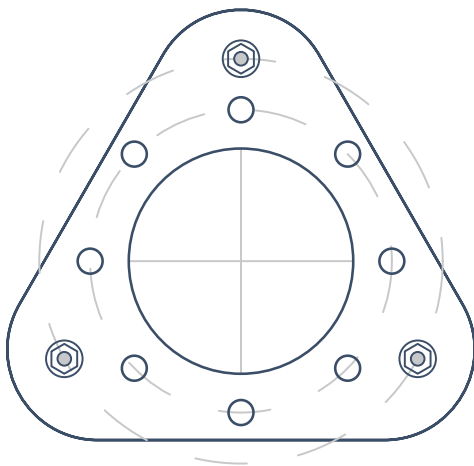

Part-Number	Size Inches
PB-R-200	2 X 6 FF
PB-R-250	2-1/2 X 6 FF
PB-R-300	3 X 6 FF
PB-R-400	4 X 6 FF
PB-R-500	5 X 6 FF
PB-R-600	6 X 6 FF
PB-R-800	8 X 6 FF
PB-R-1000	10 X 8 FF
PB-R-1200	12 X 8 FF

STYLE # CM

Compensators Male Pipe Thread

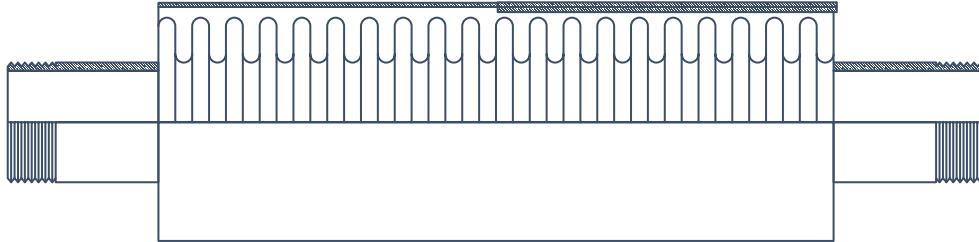

CROSS REFERENCE

Hyspan
8500
Metraflex
HP

Senior-Flexonics
H & HB
Unisource
EC-MMT

Part-Number	Size Inches
CM-075	3/4 X 12-1/8
CM-100	1 X 12-1/8
CM-125	1-1/4 X 14-1/8
CM-150	1-1/2 X 14-1/8
CM-200	2 X 14-1/8
CM-250	2-1/2 X 15-1/2
CM-300	3 X 15-3/16
CM-400	4 X 15-3/16

STYLE # CMS

Compensators Sweat Ends Bronze

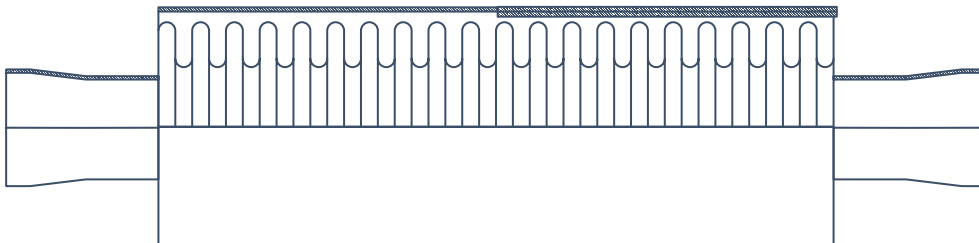

Part-Number	Size Inches
CS-075	3/4 X 12-1/2
CS-100	1 X 12-1/2
CS-125	1-1/4 X 13-13/16
CS-150	1-1/2 X 13-13/16
CS-200	2 X 13-13/16
CS-250	2-1/2 X 14-7/16
CS-300	3 X 14-7/16

STANDARD TERMS AND CONDITIONS

ALL ORDERS ACCEPTED WILL BE SUBJECT TO THE FOLLOWING TERMS AND CONDITIONS OF SALE UNLESS OTHERWISE SPECIFIED IN OUR PRICE LISTS OR QUOTATIONS:

1. Price and terms are subject to change without notice.
2. Minimum credit sale is \$50.00 per invoice. Cash minimum is \$25.00.
3. All prices are F.O.B. Sellers dock. Shipments will be made via cheapest and fastest way known to us unless otherwise specified by the Buyer.
4. All orders are taken subject to Sellers acceptance. Regular terms to approved credit are: due within 30 days
5. Seller shall be excused and not liable for delays caused by Buyers request, labor troubles, materials shortages, damage to plant, government regulations or any cause, similar or otherwise beyond Sellers control.
6. In filling orders Sellers shall be entitled to increase contract prices to conform with Sellers prices in effect at time of shipment. Such price increase subject to approval of Buyer prior to shipment.
7. Merchandise is warranted to be free from defect in material or workmanship. Liability under any express or implied warranty is limited to the purchase price of any merchandise proved defective, or at Sellers option, to replacement of the merchandise after making a pro-rata charge for service rendered if appropriate.
8. Prices quoted do not include charges for special packaging.
9. Seller warrants the goods will be produced in accordance with the Fair Labor Standards Act of 1938, as amended, and in compliance with regulations and orders of the U.S. Department of Labor issued thereunder. Seller further warrants that all prices comply with applicable price regulations.
10. Delivery of ten per cent (10%) over or under the quantity specified shall at the option of the Seller, constitute fulfillment of the order. An excess, not exceeding 10% shall be taken and paid for by the Buyer. Credit will be given the Buyer for any deficiency.
11. Goods returned without our permission will not be accepted for credit consideration. Orders for standard stock merchandise are subject to cancellation or return only on a basis that will compensate us for packing and other costs incurred prior to receipt of cancellation, (normally 15% of selling price). Orders for custom made items are not subject to cancellation once production has started nor may they be returned once shipped. Orders for standard line non-stock merchandise may be accepted for return with credit contingent upon the willingness of our supplier to accept the return and the subject to our suppliers restocking and freight charges.
12. Buyer agrees to indemnify and hold Seller harmless against loss, liability and expense resulting for infringement or claimed infringement of patents or trademarks on products made to Buyers specifications, blueprints or designs.
13. Information published in our catalogs, price lists and other schedules is based on manufacturers data and laboratory tests supplied to us which we believe to be reliable. Global-Flex Mfg. can not guarantee the suitability of the material for a users particular application; it is, therefore, recommended that each user make his own tests to determine the suitability. Applications requiring materials or physical properties, other than those listed in the catalogs, price lists or schedules should be referred to Global-Flex Mfg. for quotation.
14. Molds, tools and dies made for Buyer to produce a special product to Buyers specification become Buyers property. In consideration of the engineering service necessary in the design of molds, tools or dies, they may not be claimed by the Buyer unless an additional payment of 25% of the price charged for the mold, etc., is made to the Seller. Molds furnished by Buyer will be maintained by Seller at Buyers expense.
15. Seller does not agree to any terms and conditions except those set forth herein and its current price schedules or quotations. Shipment of any merchandise by Seller will be on said terms and conditions and no modification shall be effected by the acknowledgment or acceptance of any purchase order forms containing different terms and conditions from those set forth herein.
16. All items purchased on this invoice will be subject to our standard terms and conditions unless specified otherwise in our price lists and schedules or quotations. (See over). Merchandise returnable only with our consent 15% handling charge on all material accepted for return. Delivery of ten percent (10%) under or over the quantity specified shall constitute fulfillment of the order. Interest at 1 1/2% per month (which is 18% per annum) will be charged on all accounts 30 days past due from date of the invoice.
17. All of our products are sold for use by qualified industrial users in a manufacturing or processing plant environment and not intended for household consumers in home use.
18. No variation from these terms and conditions will apply to any sale or be binding upon the seller unless specifically stated in writing approved and signed by an authorized officer of the seller.

Global  Flex Mfg.

Your Success is Our Success.



Global  Flex Mfg.

Your Success is Our Success.

WWW.GLOBALFLEXMFG.COM

1580 CHARLES DRIVE REDDING, CA 96003 | 530-229-1320 | FAX 530-229-1329 | INFO@WWW.GLOBALFLEXMFG.COM