



US PATENT # 8,235,419 B

Installation Manual Generation II Harley Heritage Softail Models 2018-Present

**Copyright 2018, Pete Giarrusso, Inc.
D/B/A Chopper Design Services
All Rights Reserved**

Table of Contents

INTRODUCTION	4
WARRANTY	5
INSTALLATION INSTRUCTIONS	6
PREPARE FOR INSTALLATION	7
PREPARE LEFT SADDLEBAG	8
CONTROL SWITCH BOX	9
WIRING HARNESS	11
LEG & MOUNT ASSEMBLIES	15
RUNNING AIR LINES	16
INSTALL THE COMPRESSOR	19
INITIAL SYSTEM TEST	21
MOUNT PROXIMITY SENSOR	22
FINISHING UP	24
<i>FINAL ADJUSTMENTS & MAINTENANCE MODE</i>	<i>25</i>
<i>MAINTENANCE MODE</i>	<i>25</i>
<i>WHEEL ADJUSTMENT</i>	<i>26</i>
TEST RIDE	29
ILLUSTRATIONS	31
HARDWARE LIST	32

INTRODUCTION

This manual covers installation of the Generation II LegUp LandinGear system by Chopper Design Services. This system should only be installed by a qualified technician, or those with above average mechanical skills. If you are not **SURE** that you can perform this installation, please contact us and we will help you find a qualified shop to assist you.

While the Generation II System holds your bike upright very well, you are **STILL** responsible for balancing the bike! The system **WILL** relieve you of some of the weight of the bike and help you avoid balance problems as you approach a stop, maneuver at slow speeds, and back the bike up.

Improper installation will void your warranty, so please be very careful!

Thanks for choosing LegUp!

Warranty

Chopper Design Services warrants the LegUp system for a period of one year from date of purchase. This warranty covers replacement parts and/or manufacturer defects. Incidental damages or costs are the responsibility of the purchaser.

Defective parts are to be returned to Chopper Design at the address below. Purchaser must contact Chopper Design to receive a Return Material Authorization, prior to returning defective parts to Chopper Design.

Abuse, improper installation or use, collisions or accidents, are not covered under this warranty. Replacement parts for this type of damage are available through Chopper Design.

Users of the LegUp system agree that Chopper Design is **NOT** responsible for personal injuries or damage to property arising from the use of the system. While we believe this system to be safe and reliable, the user is advised that use of LegUp is done so at the users' own risk. Use of the system implies agreement to the above statements. If you can't agree with the above, Chopper Design and its dealers would be happy to refund your full purchase price, before you install the LegUp System.

Chopper Design Services
1365 Bennett Dr. #101
Longwood, FL 32750

407-834-5007
LegUp@LandinGear.com

Installation Instructions

The LegUp® system has many components. Please be sure you have them all before starting your installation.

COMPONENTS:

- 1) **Wire Harness W Switch Box**
- 2) **Leg and Mount Assembly (L/R)**
- 3) **On-board Computer Module**
- 4) **Proximity Sensor**
- 5) **Saddlebag Mounted Compressor System**
- 6) **Hardware Bag**

If you believe you are missing any parts, please contact Chopper Design at 407-834-5007, and we will rectify the situation. Some of the parts are shown below.

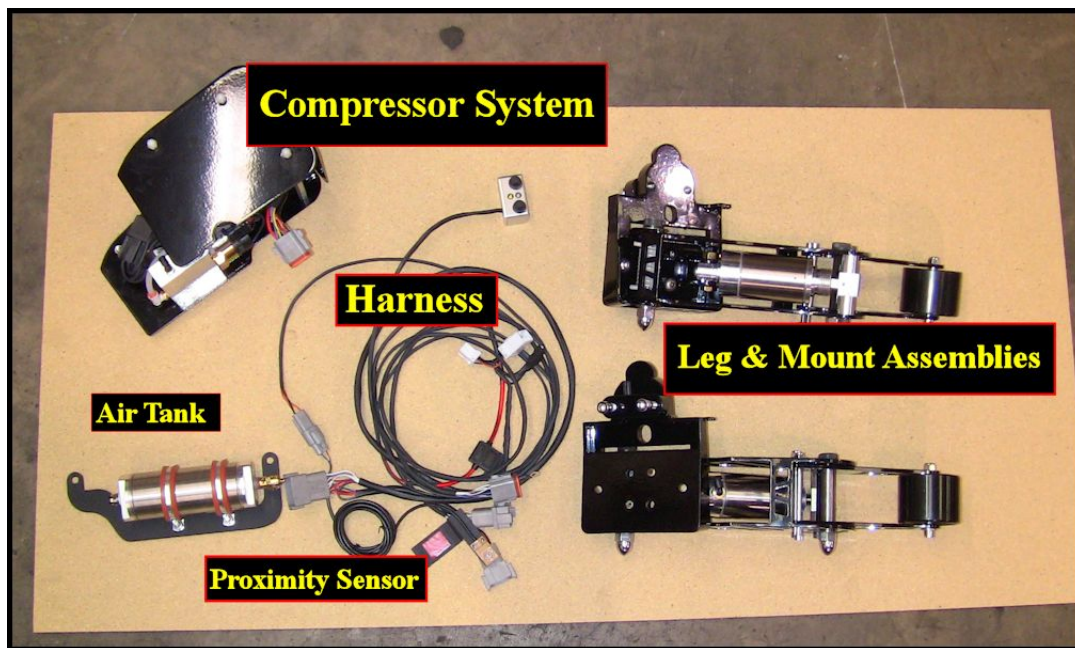

PREPARE FOR INSTALLATION

IMPORTANT! *Harley 2018-Up Heritage® must be at STOCK height in order to install LegUp. This system is designed to fit 2018-UP Heritage models only! While accommodations for other Softail models may be able to be made, we can only guaranty fitment to the 'STOCK' Heritage models. Please contact Chopper Design for help with fitment on anything but the above model in a completely 'STOCK' condition.*

We suggest that you read this **ENTIRE** manual before starting this installation. It will save you time and frustration!

Place the motorcycle on an acceptable bike lift. You will need to keep the bike on its wheels for most of the installation, and jack the rear wheel off the lift for some portion of the installation. Make SURE the motorcycle is secure on the lift!

Remove the seat. Remove the left saddlebag, both side covers under the seat; and the rear foot-pegs.

This manual is available at <http://landinggear.com/pdf/g2installmanuST18.pdf> . It may be easier to see some of the pictures in color there.

Let's begin!



PREPARE LEFT SADDLEBAG

One of the first things we want to do is to drill a small hole in the left saddlebag to allow the air lines to enter the bag.

Make note of the area we are showing you in the picture below. We want to drill a single 3/8" hole here. The back of the bag is very soft plastic so no pilot hole is needed. There are two things to watch for here. Make sure you have the left bag, and make sure you drill the hole where we show you.

We are going to run 2 small airlines through this hole. It is high enough and hidden enough that it should not allow any water infiltration. If you are still concerned, once we reinstall the saddlebag, you can use silicone to seal this hole.

Exact placement of the hole is not terribly critical. Once complete it should look like the bag below.

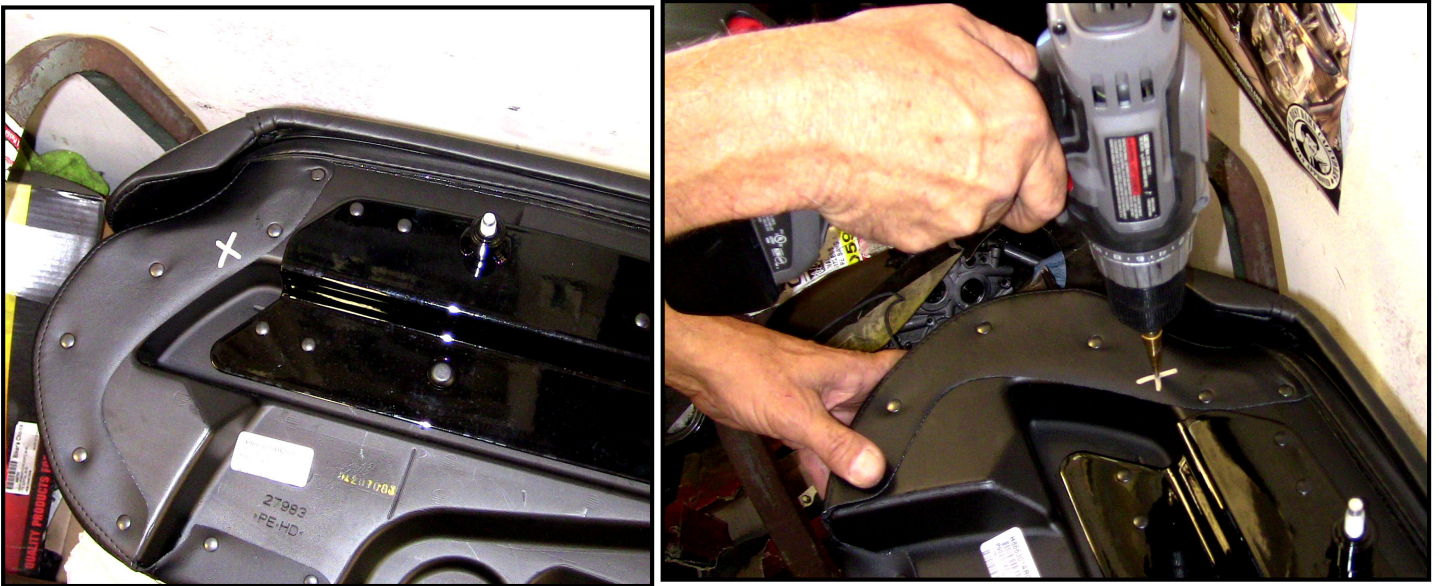

The next step is mounting the Control Switch Box.

CONTROL SWITCH BOX

Remove the bolt on the top of the left switch housing on the handlebar. Find the long chrome bolt, thread it through the Control Switch Box, insert the spacer on the bolt and (with a drop of Blue Loctite), and thread the bolt into the switch housing. Square the box before tightening the bolt (you may have to re-align the mirror for clearance).

Route the wire inside the clutch lever and down the clutch cable. Use wire ties to hold the wire to the cable. Run the wire through the hole in the middle of the top triple tree. The idea here is to get the wires neatly to the front of the tank and routed under the tank. (It may be easier to tape the silver plug ends together for this). We have some pictures below to give you an idea of what this looks like.

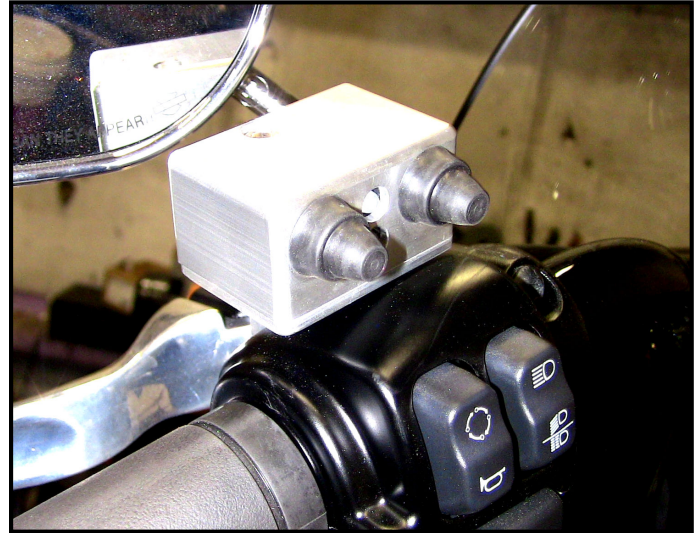

We don't loosen or remove the tank; we just run the wire tight to the bottom of the tank and find a wire to tie it off to. Make sure the wires do not interfere with anything under the tank, and that there is nothing that would scuff the wires. Put the wire through the high frame hole on the left side as shown in the picture below. Notice how we ran the end under the metal flange in the picture to keep it away from the shock.

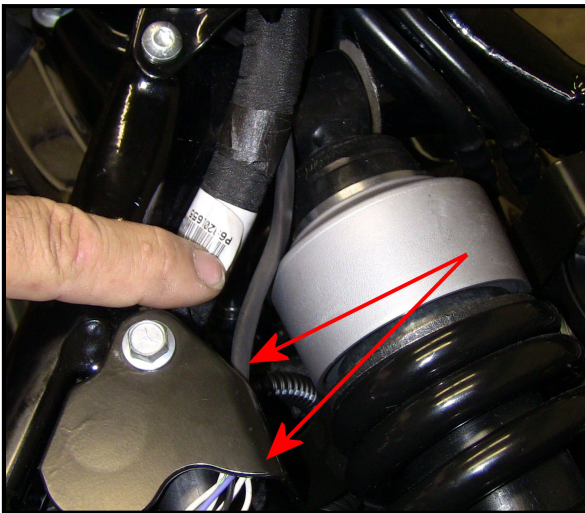

Once the wires are under the seat area, you can assemble the plug, according to the diagrams on the next page.

More mistakes occur putting these plugs together than anything else. The pins are pushed through the rubber holes into the plug until they click. The pins need to be completely flush with the edge of the plug. Then the orange insert is pushed into the opening. The wiring details are found on the next page. Be VERY careful to get the wires in the correct hole; all the colors match to the mating plug!

Pin Out for Handlebar Control Box Plugs

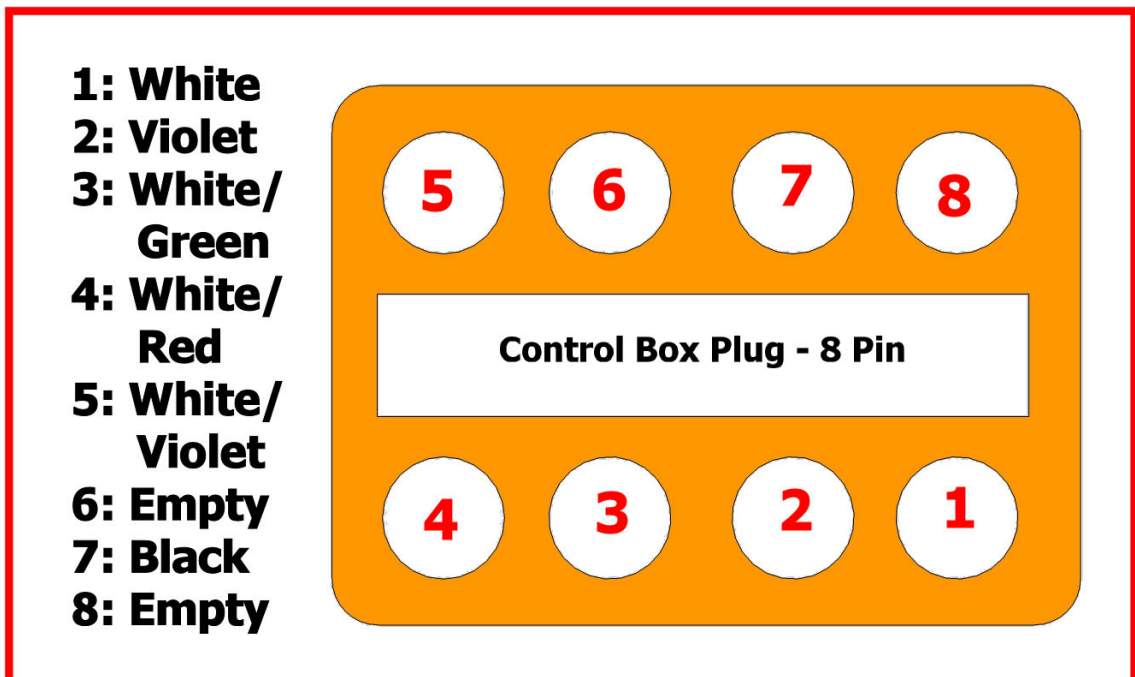
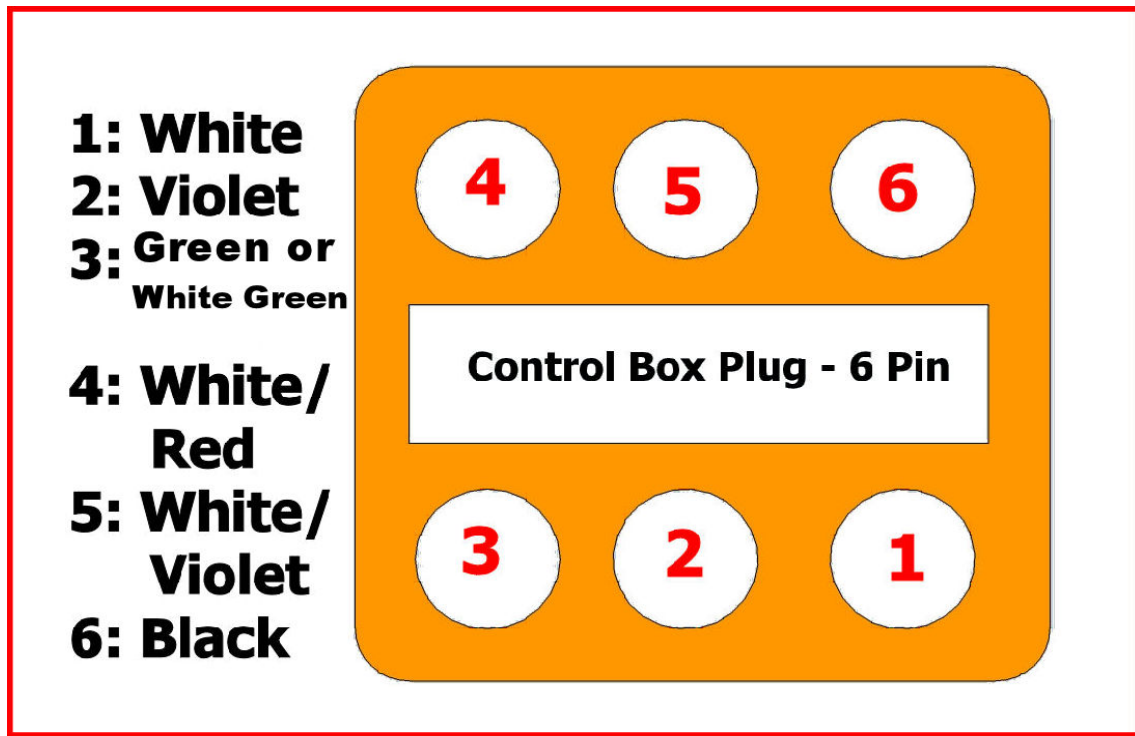

WIRING HARNESS



The harness and the plugs are routed mostly under the seat. Different models have different amounts of space in this area, and all the wires are long enough to allow you to place the connectors in the best place for your bike. What you need to do is get the (2) six pin plugs to the area under the seat. The large 12 place plug and the connected 8-Pin plug attach to the Computer and Compressor respectively, and they need to land near the left saddlebag. Push the 12-pin/8-pin wire through the hole shown here between the

fender support and the rear fender. We are going to tie this wire up under the fender support, so pull most all of the slack toward the back of the bike, until you have 16" of wire past the end of the fender support as shown below.

We loosened the two remaining bolts on the fender struts to allow us to slide the 3 wire ties you see here under the strut. You can see the plugs hanging off the signal here.

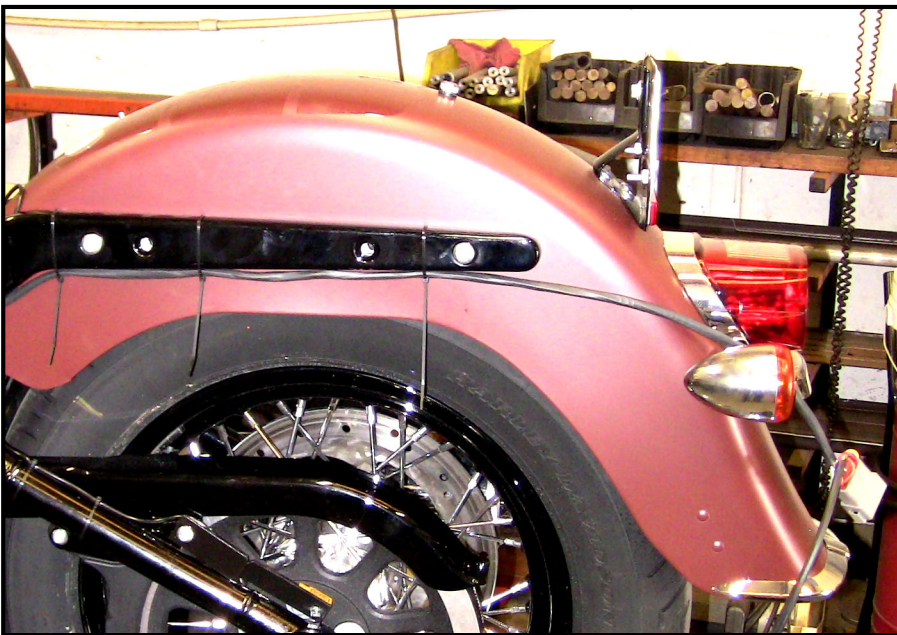

Find the proximity sensor and its three pin plug. Run the wire (plug first) through the same spot you ran the 2 plugs through, but from the fender into the area under the seat, so you can plug the 3-pin plug into its mate under the seat. Leave the sensor and its mount dangling for now; it will be mounted later.

The most difficult part of the wiring is getting the connection to the battery (Whodathunkit?).

With both side covers off, from the right side of the bike we need to get the cover off the battery so we can get to the positive terminal and make a connection there. You need to remove the oil dipstick to allow you to remove the small plastic cover and the wires seen in the picture below left.

Next, using a 10mm wrench, remove the negative battery strap from the battery. Then, snap the metal clip back, as seen in the right picture below. There are two other plastic clips holding this cover that need to be moved to allow the cover to slide back.

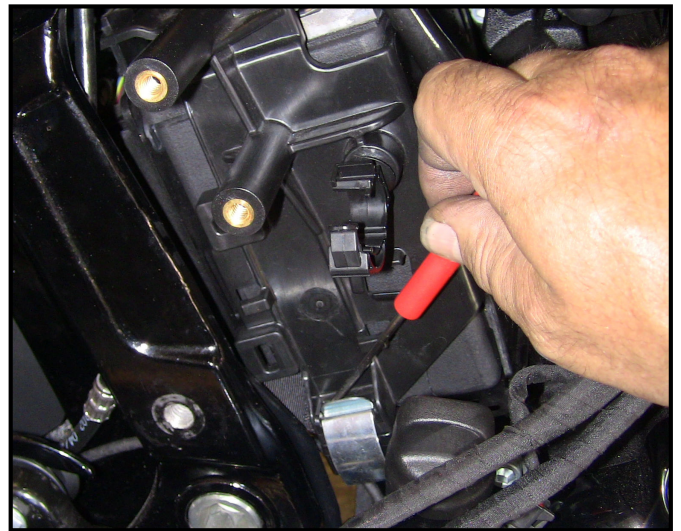
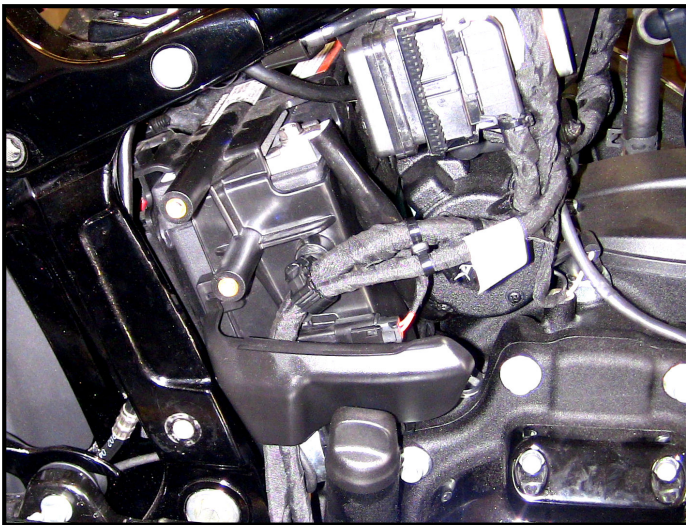

Assuming you got the cover loose, slide out the left side just a bit, so we can finally see the positive battery terminal. Carefully remove this screw from the battery. Find the 2 hoop connectors on the wire harness.

We need to run the battery bolt through the connector on the wire that has the fuse holder on it, then carefully through the battery cable, and re-attach this to the battery.

Once this is attached, find the bolt on the frame shown by the top arrow below, remove the nut, and capture the other hoop connector on the harness to the bolt and reinstall the nut (10mm).

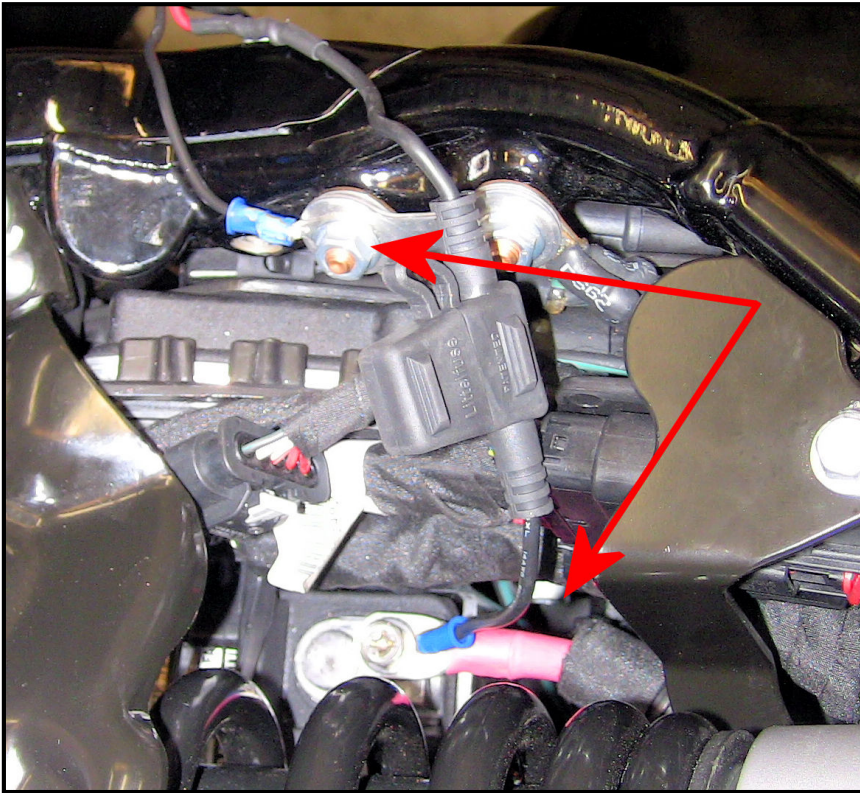

The attachment to the battery and frame are now complete and should look like the picture above. Make sure there is a fuse in the holder, and you can get the battery cover reinstalled. Don't reconnect the negative battery terminal just yet.

Let's plug some things together!

If you have a 21 or later model, you will find a single orange wire that will need to be connected to a 12 volt switched power supply and we have no plugs to fit these models. We supply you with a quick connect device to help you with this. Feel free to call if you don't understand.

Otherwise (2018-2020 models) there is a six pin connector with just 2 wires on it that needs to go to the area that would be under the left side cover. We need to get this plug and wire under the frame rail and find the six-pin diagnostic connector in the area shown here. The connector on the bike will likely have a rubber plug in it. Remove the plug and plug the harness plug (1 or 2 wires, orange and maybe black; later harnesses have no black) into the connector, and tuck it back where it was. Make sure the wire is safe, and use wire ties to be certain it can't hit the belt or any other moving parts.

Connect the Control Switch Box plug (six pin with 6 wires) to its mating connector under the seat, and plug the proximity sensor plug (3 pin) to its matching connector.

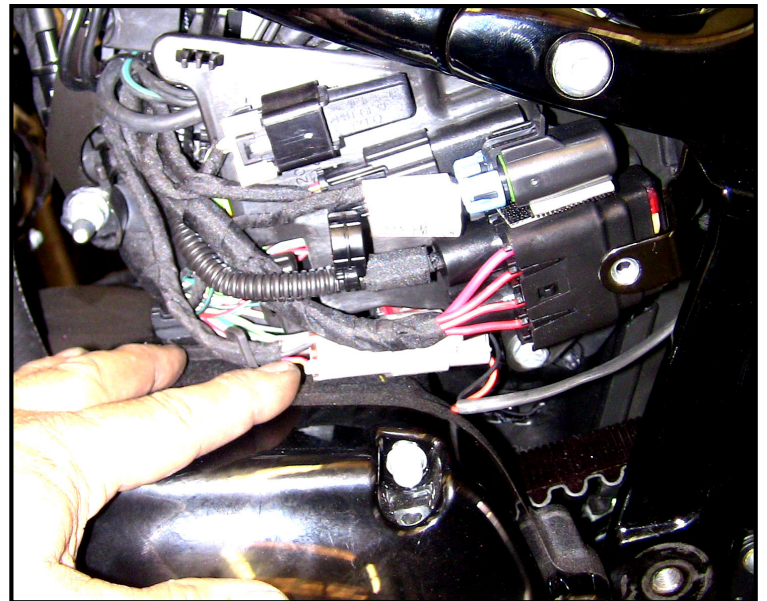

If everything went according to plan, you should have all plug connectors under the seat plugged to their matching plugs, the positive battery lead (with fuse holder) should be connected to the positive battery terminal, there should be a wire attached to the frame for ground, and on the left side you should have two big plugs waiting for a home (hanging off the fender strut), and the proximity bracket and sensor, with no place to go quite yet!



Next, if not done already, we need to secure the wires that go into the saddlebag to the left fender rail, and leave enough wire for the plugs to reach the computer and the compressor. What we want to do here is take three wire ties and carefully thread them between the fender strut and fender as shown here. It may be necessary to loosen the two fender strut bolt to get the ties through.

Run the wire under the fender support and tie it off. Make sure you have 16 inches of wire sticking out from the end of the saddlebag rail,

and that the wire is tight to the support. You can now pull the extra wire back into the under seat area. Later we will be securing air lines to this wire, so make sure that will be possible with your choice of how to attach this wire!

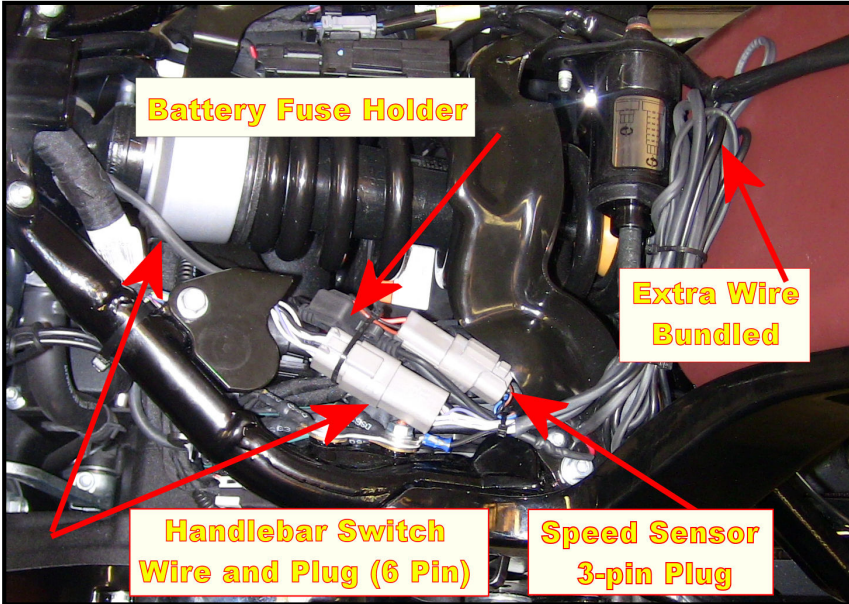

The only wires left dangling should be the 2 big plugs at the back and the proximity sensor and mount, which we will handle soon. While we are not going to tie up all the wires yet, below is a picture of how to do so when you are ready.

Just make sure that the seat goes on without crushing anything and all wires are tied up out of the way and safe.

Let's mount the legs!

LEG & MOUNT ASSEMBLIES

IMPORTANT! *The GEN II LegUp system replaces your rear foot pegs. We will ship your system with Touring-bike style floorboards installed. Your existing rear pegs/floorboards MUST be removed!*

Now we need to mount the Legs to the bike. As previously described, we need to remove your rear pegs. We also need to remove the rearmost bolt from the fender struts. We will hang the mounts from these two bolt holes.

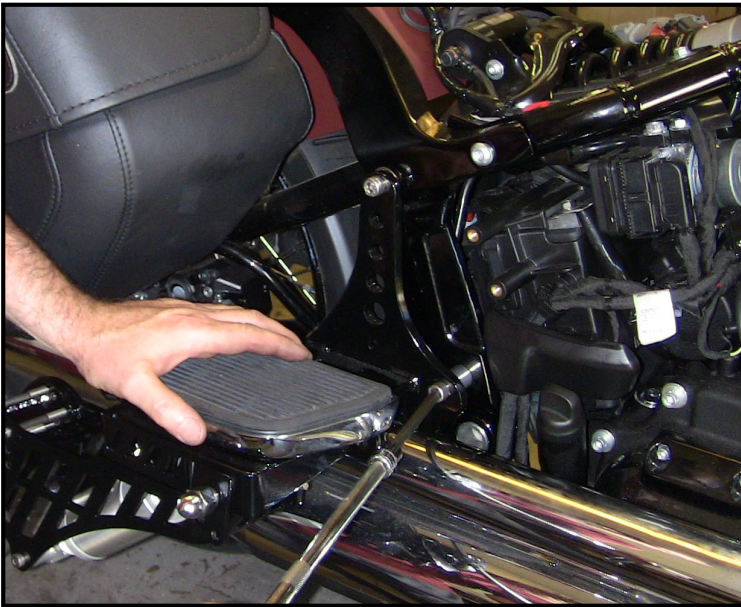

Find the right side leg assembly shown here. Find (2) 3/8-16 X 2.25" Allen bolts, (2) 3/8" flat washers and (1) 3/4" aluminum spacer.

Offer the mount up over the exhaust pipe. Run the top Allen bolt through the mount, then through the 2 washers and through the stock washer removed when the bolt was removed from the fender strut and start threading into the fender strut hole. Leave the bolt loose for now. You should use some Blue Loctite on these bolts.

Next install the lower bolt through the mount then through the 3/4" spacer into the hole vacated by the rear foot-peg you removed. Alternately tighten both bolts until the mount is VERY snug!

The left mount requires (2) washers, a 3/8" spacer and a 3/4" spacer. The top bolt goes through the mount, then the 3/8" spacer, then the stock washer and into the fender strut.

The Bottom bolt goes through the mount, then (2) 3/8" washers, then the 3/4" spacer into the foot-peg mount hole. Again, Blue Loctite, and tighten the bolts snugly.



Both Legs should be very tight to the bike; give them a tug to be sure! Let's run the air lines!

RUNNING AIR LINES

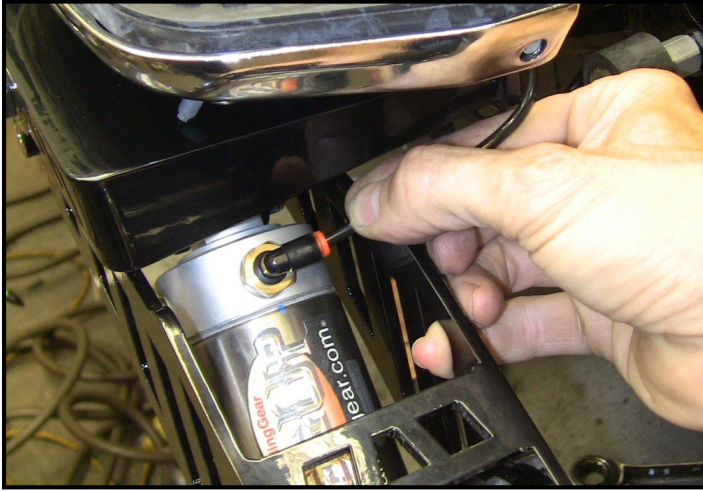

We need to route the air lines from the cylinders to the area near the left saddlebag. You should find 2 long air lines of identical lengths. On the right side of the bike, press one end into the fitting on the back of the air cylinder. These press in relatively easy, but a small tug will make sure the line is seated.

On the right side, guide the line above the mount toward the front of the bike. We need to use 2 wire ties to hold the line where we need it before it goes into the battery area. Don't over

tighten the wire ties. Once in place, manually push the leg down and allow it to retract a few times making sure the line stays away from the pipes.

Once you are sure the line is safe and not binding, one more wire tie through the top hole on the mount will keep the line out of the way just before we guide it up into the area under the seat.

This line needs to get to the left side of the bike safely; we ran it just under the wire that runs to the rear lights to keep it in place without any ties.



On the Left side, install the line through the hole in the mount, then into the cylinder as shown at left.

This will give us a good start on running the line forward and keeping it away from the drive belt. Move the leg up and down to make sure you have enough hose before the next steps.



Look at the pictures below for the best way to run this line safely!

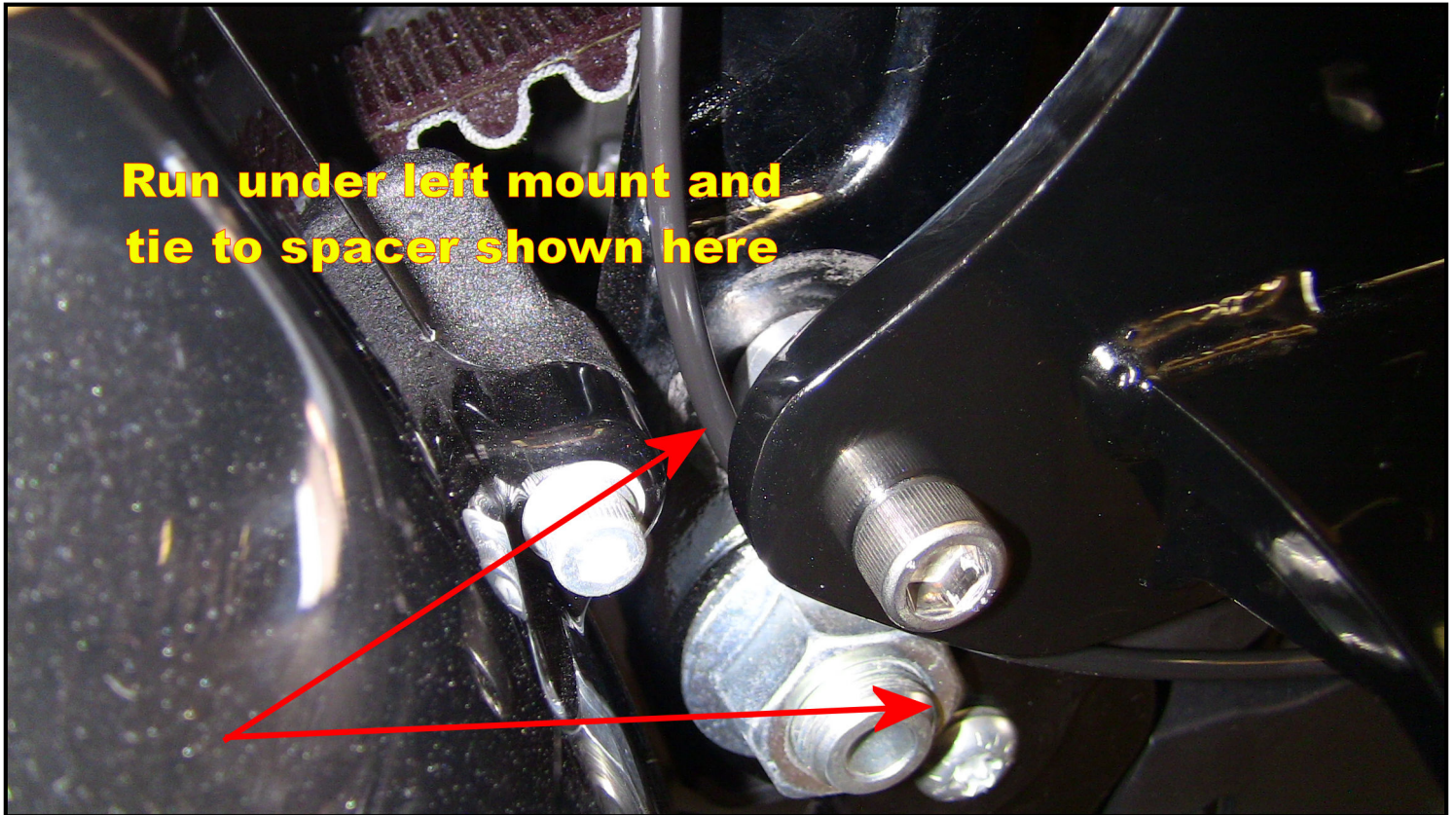

Once the lines are run as shown we want to get both sides under the left fender strut to be tied loosely to the harness wires running there. This will allow us to get the lines safely into the saddlebag.

(NEXT PAGE)

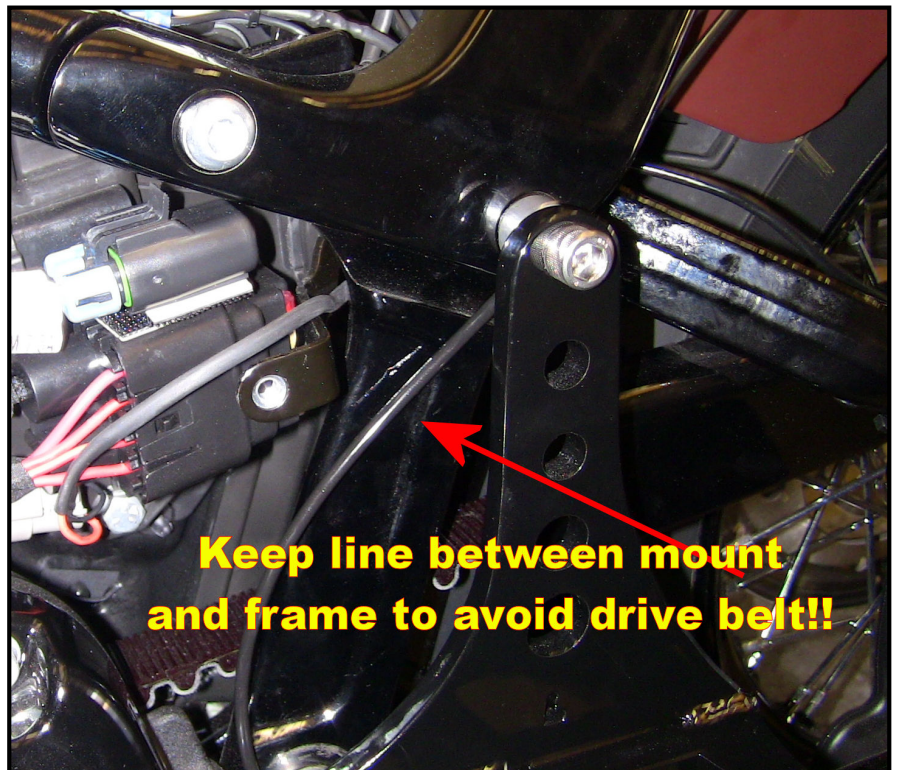

See how we have lightly tied both lines to the harness under the fender strut. Again, don't tie these too tightly as to restrict air flow through the lines.

Notice the excess line is hanging at the back, soon to be installed into the saddlebag.

At this point, let's push down and let go of each leg in turn to make sure they return smoothly and that the lines allow the legs to move freely.

on the swingarm. Once everything is tied in place, try to see if the hose can reach the belt. If it can, you must adjust the ties until the hoses are safe. Whatever you do, it is critical that the lines can't get burned or scuffed. A little extra patience here will relieve tons of frustration later from holes in the air lines.

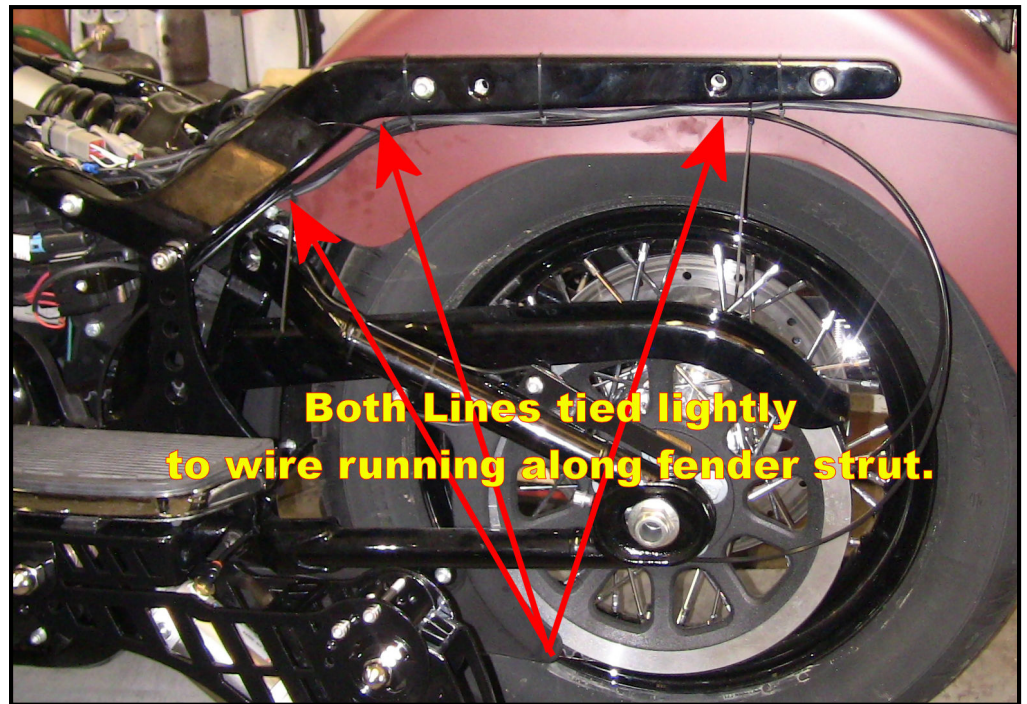

INSTALL THE COMPRESSOR

Now that the air lines and wire harness are ready, we need to re-mount the left saddlebag and install the compressor. While mounting the bag, run the two air lines into the hole you drilled earlier. We like to place the forward mount on the rubber mounting isolator so it is supported, and tilt the bag to get the lines in as seen here.

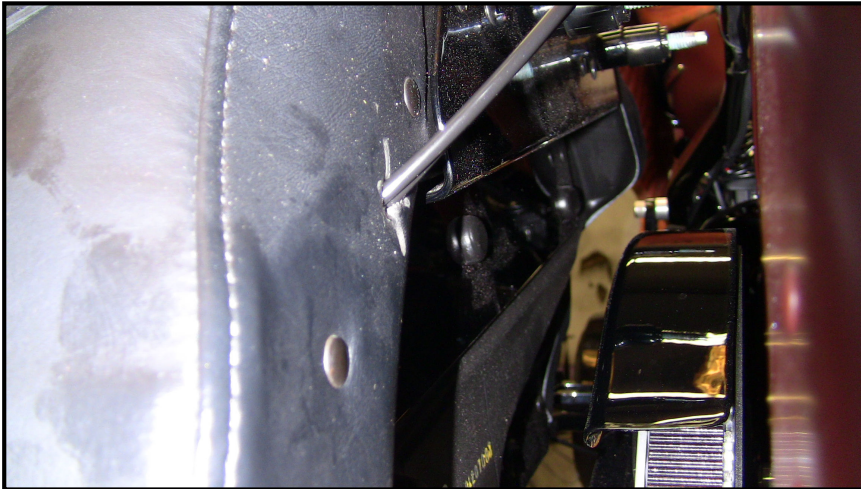

Install and tighten the mounting bolts inside the bag, Make sure the bag mounts are tight!

Next we want to attach the air lines to the compressor. On the compressor should be two short air lines with fittings on the ends. You may want a bit of help here to keep the saddlebag open.

Perch the compressor on the top ledge of the open bag. Notice that the tank goes toward the front of the bike as you can see below. Attach the air lines from the bike to the connectors attached to the compressor (red arrows). These lines simply push into the in-line connectors as they did on the cylinders on the legs.

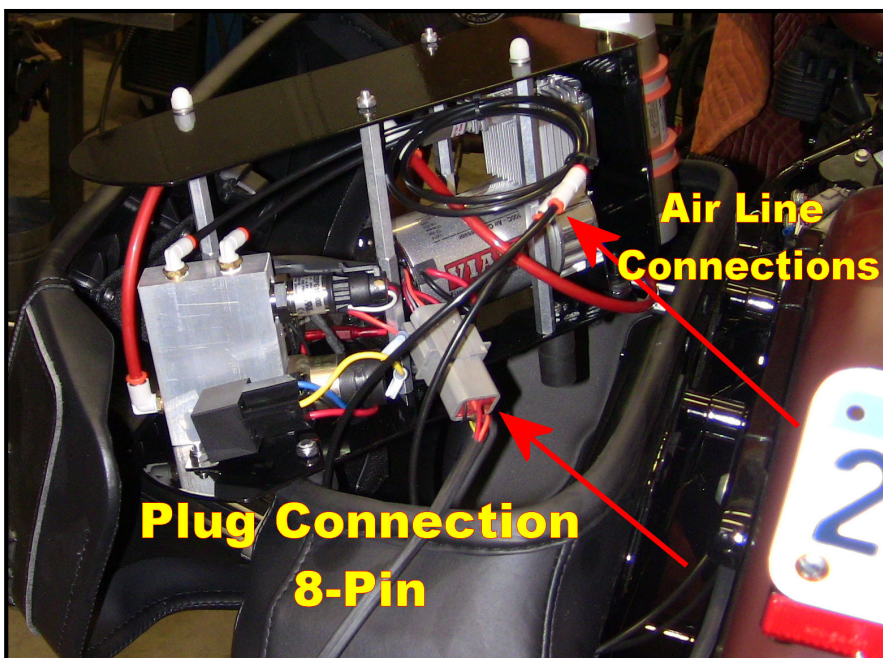
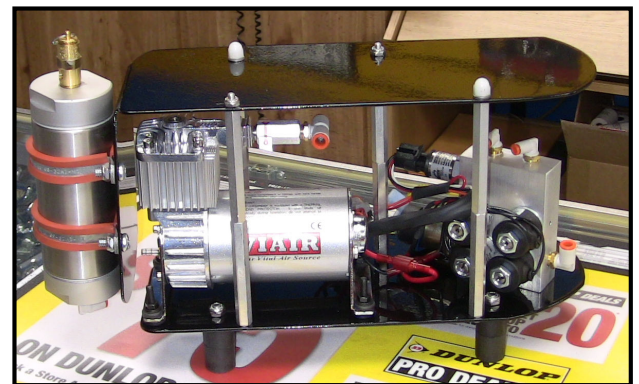

Once the air lines are attached, plug in the 8-pin connector to the connector on the compressor. It only attaches one way; make sure it is solidly attached. At this time, make sure you keep the 12-pin plug above the top of the compressor, so you won't have to fish for it once the compressor is in the bag.

Tilting the front of the compressor system toward the outside of the bike, carefully lower it into the saddlebag, allowing it to settle into a spot as far back as it can go. The compressor should feel secure where it sits; it sits on Rubber feet so it will move a bit.

Assuming you are happy with its placement, find the computer and plug it into the 12-pin plug you kept above the top of the compressor while installing.

Attach the computer to the top using the supplied Velcro, with the wire facing rearward.

Pull all extra slack from the harness into the bag (make sure the bag closes easily!). You want all the plugs, extra wire and air lines pushed toward the back and below the level of the top. Once complete, you should be looking at something like the picture below. Next we will tidy some things up.

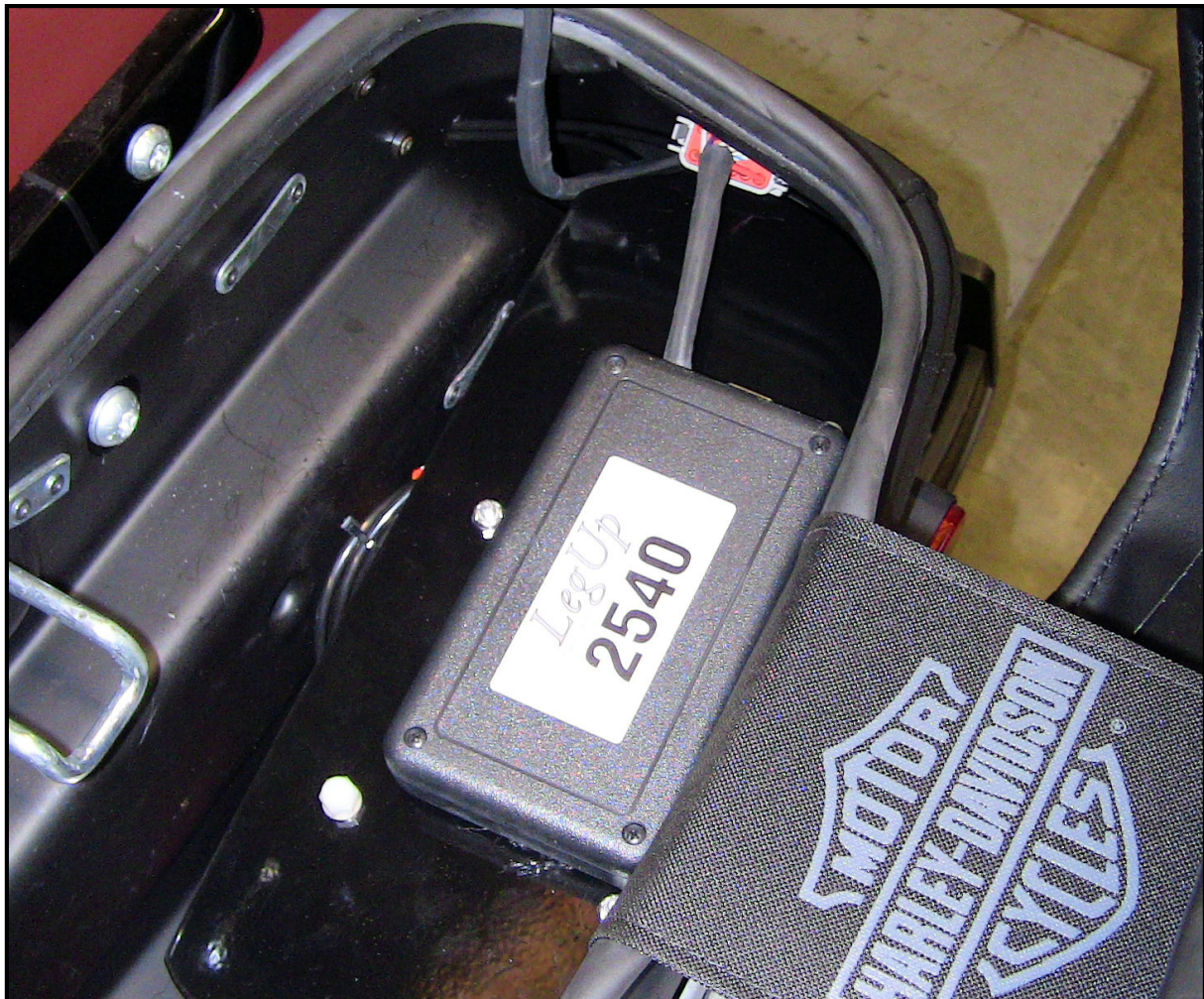

INITIAL SYSTEM TEST

For the time being, assuming all the plugs under the seat are plugged in, we need to plug the computer into the 12-pin plug hanging off the left fender strut. If you did not attach the negative cable to the battery, this would be the time to do so! Find the compressor and put it somewhere stable (on the lift is what we do), and plug the 8 pin plug into it. We just want to make sure everything is working!

Turn on your bike. If everything is working properly, the compressor should turn on for about 6 seconds to fill the onboard air tank. At this point, have a look at the yellow proximity sensor.

PLEASE NOTE: Immediately after turning on your bike (within 5 seconds), the top light on the handlebar control will flash for a few seconds. This is the system either making sure that no air is in the legs if they are up (for safety it makes sure air does not build up when the legs are in the up position), or that the proper amount of air is in the system if they are down (again for safety to make sure the legs stay pumped completely!). This test occurs once a minute for all the time the bike is powered up, whether you turn the LegUp system on or not!

The **RED LED** (ON The Sensor) *Should Not Be Lit*. Take a metal object (screwdriver, wrench, etc.) and hold it on the flat face of the sensor (it has a circle embossed in it). The LED should light up, and go out when you move the metal away. If not, check all your connections.



Next, press the rightmost pushbutton on the handlebar switchbox, and hold it for at least 3 seconds. Both LEDs on the switch panel should light up; green means the legs are up and yellow means the bike is traveling under 6MPH. If this occurs, you are doing well.

The next step requires some care. If the bike is still on the lift, have a helper hang on to it as you touch the left button for just a split second. The legs should move down, likely until the wheels hit or miss the lift, and they do this **VERY** quickly! The compressor will likely start and run for about 10 seconds. Press the left button again and they should move up.

If all of the above has occurred, great! Turn the ignition switch off, the test is complete!

Let's move on to mounting the Proximity Sensor.

MOUNT PROXIMITY SENSOR

This step is crucial!! Understand it before starting. The proximity sensor tells the system how fast the bike is traveling. The proximity sensor mounts to the swing-arm at the rear pulley. It will mount 5MM from the pulley. You need to jack up the rear wheel so we can spin it to test the sensor and its placement. Make sure the bike is in neutral.

With the bike up as described above, turn the bike on. The LED on the sensor should be out. Bolt the proximity bracket to the rear-most bolt on the belt guard, so the sensor aligns near the pulley bolts. Adjust the bracket so the main part of the sensor is aiming at a pulley bolt and is centered on it (you may have to turn the wheel to do this). What we are looking for is for the LED to go bright and OFF as a pulley bolt passes the sensor. Play with this by rotating the wheel back and forth while holding the bracket in place. Once you feel you have the right place,



hold the bracket steady and slowly rotate the wheel. Every time a bolt passes the sensor, the light should get bright, and turn off after it passes.

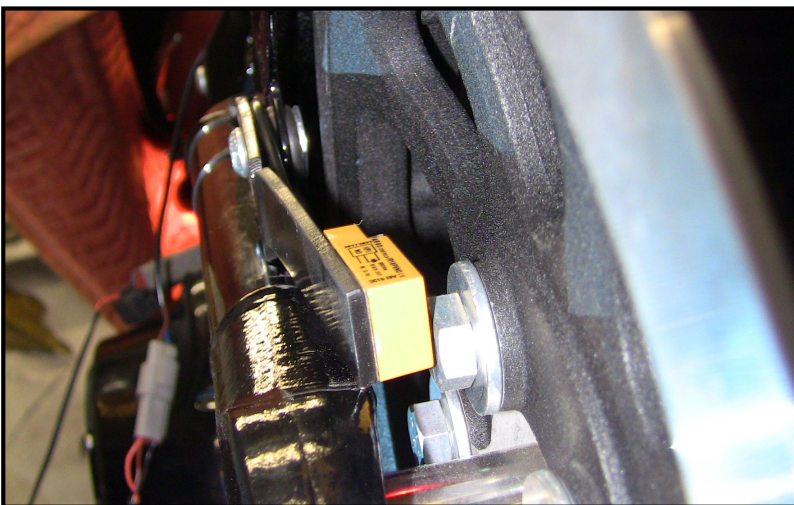

If this is not happening, you may need to get the sensor a bit closer to the bolts (5MM is a very small distance!). If you have to move the sensor closer, you may have to bend the bracket a bit. No matter what you need to do, you **MUST** make sure that as the wheel turns, the light works as described above! Once you are certain, tighten the bolts and test again! The automatic retraction of the legs as well as their deployment **RELIES** on this sensor being placed perfectly!

Once satisfied with the mount, route the wire up the swingarm making sure it is clear and safe. The arrows below show where it is tied and the plug in the area under the seat. You will need to leave a little slack as it joins the other wires under the seat; the swingarm moves and we need this slack so the wire is not broken as the wheel goes up and down. Now we can mount the compressor.

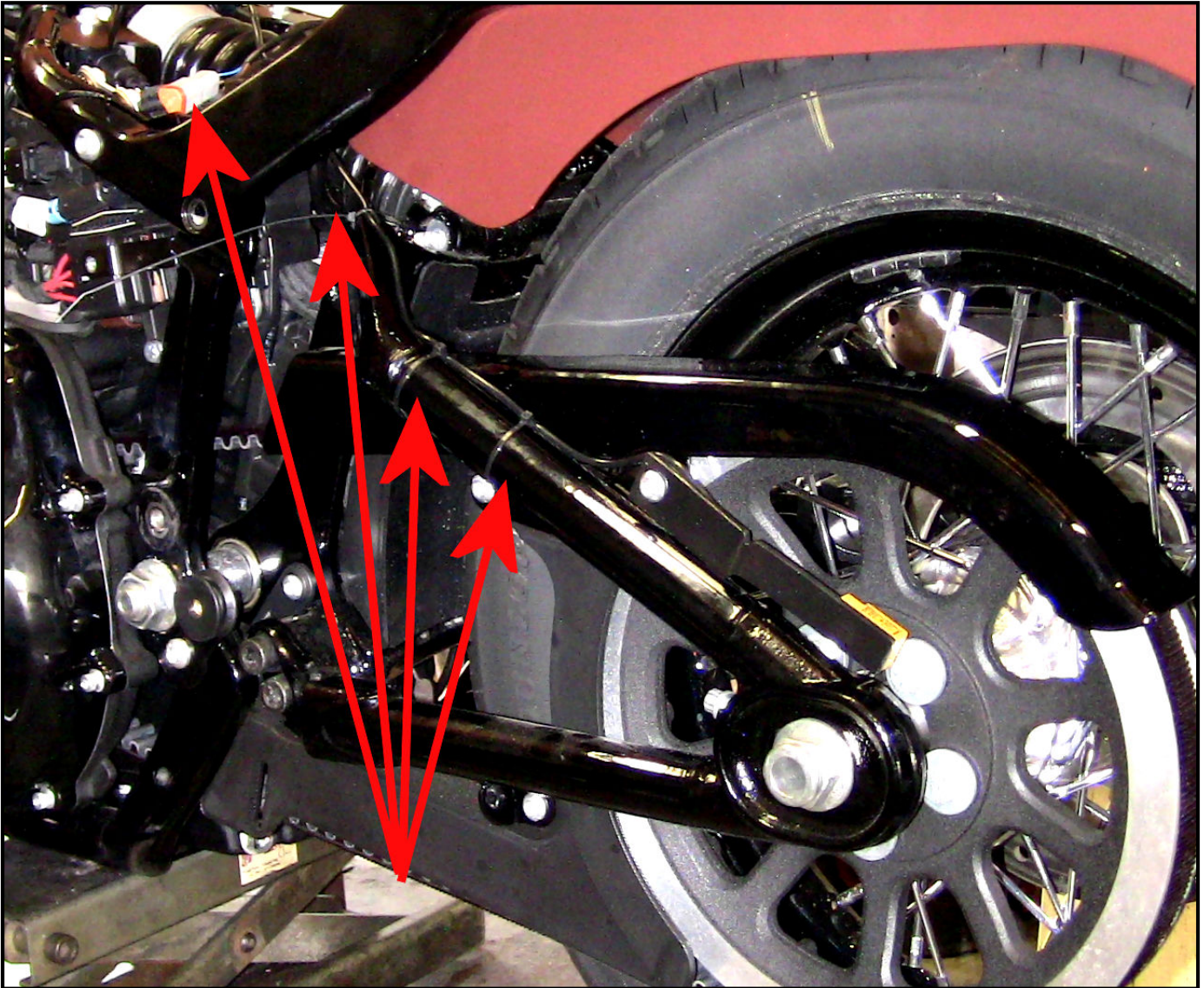

FINISHING UP

Now it is time to reinstall everything you took off, and do a final check of everything! Install the right saddlebag, then reinstall the seat making sure all your wires are routed neatly, tied off nicely and don't interfere with the seat installation.

Once all of this is accomplished, we should get the bike on the ground, and with a helper, cycle the wheels up and down a few times, having your helper make sure the air lines are not being scuffed or are over tight, and that the wires are out of the way of anything that could damage them.

Double-check all your bolts for tightness. Now we can dial in the legs, and adjust the wheels if needed.

LEAKS!

This system uses air, and air loves to leak! The fittings we use are tested for leaks before shipping, but we have a few simple tests to make sure you have no leaks or just insignificant ones if any.

Set the wheels down and leave the system on. Put the kickstand down, and turn the bars all the way left.

If the compressor makes noise more than once every two minutes, you may have a leak at the lines that connect to the compressor or the tank fittings. Some soapy water will tell you where (you will need to remove the compressor top to test for these leaks).

Assuming the compressor doesn't lose enough air to kick on after 2 minutes, you should be fine.

You can turn the bike off, and wait to see if in 5 minutes the bike is not as stable as it was when the wheels were first lowered. If it lasts the 5 minutes and is still very stable, you could still have a leak, but not one that would be a problem on the road!

Leave the bike on its wheels overnight (again kickstand down, bars full left in case the legs lose a lot of air; the bike will land on its stand). If in the morning, the bike is still stable you have no leaks.

If there are leaks, the fittings on the air cylinders would be the first for the soapy water check, with the two small line fittings on the compressor next! If you need help with these, please feel free to call us at (407) 834-5007.

FINAL ADJUSTMENTS & MAINTENANCE MODE

The next two sections are typically **NOT** needed. We include them to document your system thoroughly, but **MOST** people will never need to use either section.

MAINTENANCE MODE

NOTE: Maintenance mode is a procedure that ‘TEACHES’ the computer how much pressure to use when it lowers the wheels and how much pressure to release when raising the wheels. We always set this at the factory; ALWAYS!! We include this procedure in case it is ever needed in the future. Please skip this section unless you have been instructed to reset the system by Chopper Design.

Turn the ignition to Accessory and start the LegUp System (hold right button for 3 seconds). The system should be set at the factory for proper pressure, but some wheel adjustment may be needed. If it has been determined that ‘**Maintenance Mode**’ is needed, Sit on the bike, and hold it level. If both lights on the switch box are flashing, the system is in maintenance mode. If not, **PRESS & HOLD** both buttons until all lights flash. ***(Do your best to press both buttons at the same time so the system doesn’t respond to what it thinks is a request to lower the legs)*** Once flashing, hit both buttons for an instant to get the system in the ‘**DOWN**’ setting mode (lower, yellow LED flashing). Touch the left button briefly; the wheels should go down immediately. ***(This is VERY quick, don’t be startled!)*** Using very short pushes of the left button, press and then feel the stability of the bike. If it feels firm enough, try leaning the bike a bit. If the wheels return the bike to upright, there is likely enough pressure. Put your feet on the floorboards; the bike should stand on its’ own. Rock the bike a bit left and right, being prepared to put your feet down. If the bike continues to come back to upright, the **DOWN** stop is now set and we can move on.

Hit both buttons for a moment to get into the ‘**UP**’ stop mode (Usually hitting the left button just before the right assures that air is not released!) The top LED should now be blinking. Press and hold the right button to raise the legs. Listen as the air evacuates; once it is quiet, let go of the right button. The **UP** stop is now set! Hit both buttons when complete, Both LEDs should light, and you are done with these adjustment.

Now press the left button and the legs should lower; again this is fast and loud. The bike should be held up firmly! Hit it again and the legs should retract. If you are satisfied with these limits, you have successfully installed the LegUp System.

WHEEL ADJUSTMENT

*The LegUp GEN II system is typically set up at the factory for the height of your bike. The system is **VERY** height dependent! If after testing the initial installation, the bike does **NOT** feel stable, the wheel system **MAY** need to be adjusted to the height of your bike. **AGAIN**, we normally ask at order time if your bike is at stock height and we set the system up for whatever height you have furnished us. **DO NOT** make any changes unless the stability we expect is **NOT** present! If you feel you need to adjust the height/length of the wheel holders, please read this **ENTIRE** section before starting the process. If you need help, please contact Chopper Design at 407-834-5007.*

If you are happy with how stable the bike feels, you can skip this section, and move on to a test ride! If you are not sure, a good test is to bring the wheels down, put the kickstand down, and lean (or try to) the bike on its kickstand while sitting on the bike. If you can't lean it onto the kickstand without significant effort, you should not touch it; move on to the next section (Test Ride), the wheel settings are fine!



The stability of the GEN II LegUp system, relies on the pneumatic actuator, when deployed, being at an angle that is forward of perpendicular for best results! Different bikes are at different heights, and Chopper Design uses an ingenious method to adjust the length of the supporting legs to maximize the stability it affords.

Typically, we will send the 'Leg Assemblies' set up for the bike you told us you had. We have three different 'Standard' setups for the Harley Touring bikes. Standard FL Height, Street Glide and other bikes using the Harley lowered shocks, and the new 'Ultra Low' models. The Softail setup is just a bit lower than the standard touring bike.

The first picture (above) shows the setup for standard height Softails. The wheel holder is set with the strap facing up and the small bolts set in the 3rd and 5th hole from the back of the leg (Notice curve of wheel holder) with the bolt in the second hole on the wheel holder (wheel rotates a bit extra toward the back). The axles are set in the higher of the two holes on the wheel holder. I know this sounds confusing, but it is all part of the fine tuning of the height of length of the legs. This is how we should have sent the legs to you.

This picture at right shows the tools we have at our disposal to adjust the wheels if needed. The big bolt (#2) can be placed in 2 positions, the small bolts (#3 we have 2 of these) can be used to rotate the wheel holder a bit, and the axle (#1) can be placed in 2 different positions.

Another option you have which will shorten the leg length is to remove the wheel holder (axle and 2 small bolts out), turn it over and install it on the other side of the bike. This keeps the wheels in the correct position, and avoids you having to remove the wheels and turn them around as well.

If the bike, with its normal passenger load is not stable enough with the wheels down or it drops more than 1/2" when transitioning from wheels down to wheels up, you may wish to try some small adjustments, using the above tools.

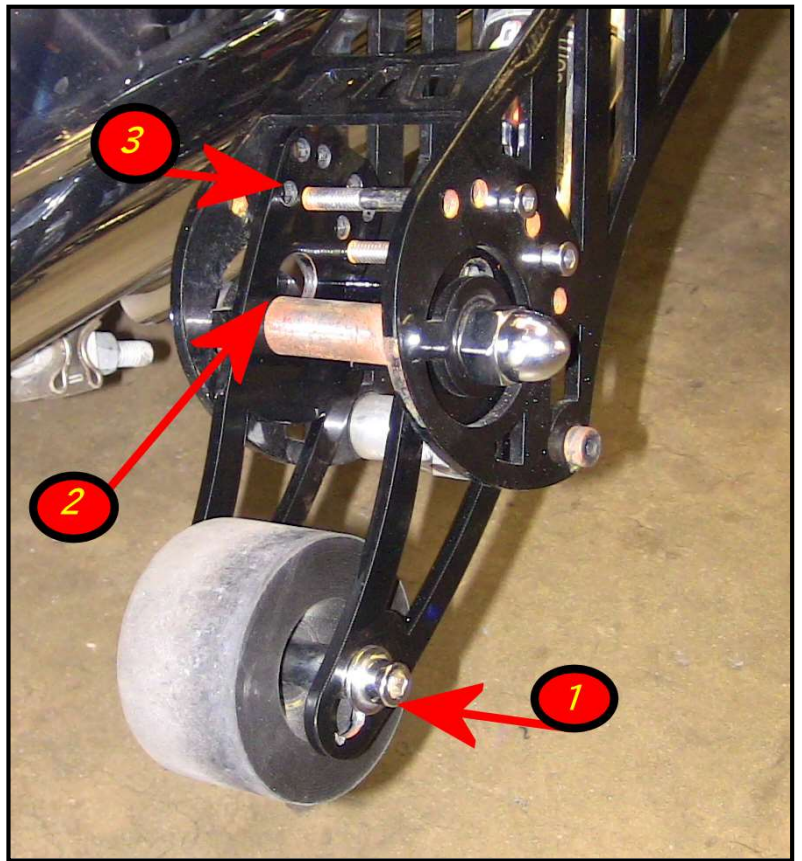

Whatever you do, try to keep the wheel holder under the leg when the legs are extended as much as possible. Rotating the wheel holder too far back lends leverage, and makes the system much less stable.

As we have said before, the system should be close if not perfect the way we send it to you. Shock condition and bike loading are the two main reasons you may wish to make these adjustments. In many cases you can contact us and send us a picture with the wheels down and rider(s) up, and we can recommend what changes to make, to get the system the BEST it can be for you. Be patient and call us for help if you are having any trouble.

On the next page we have some pictures to help you understand what we have tried to show and explain here.

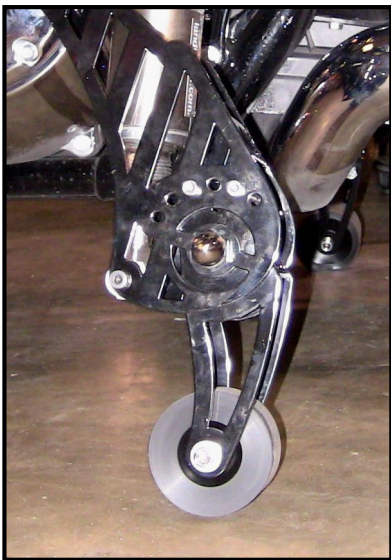
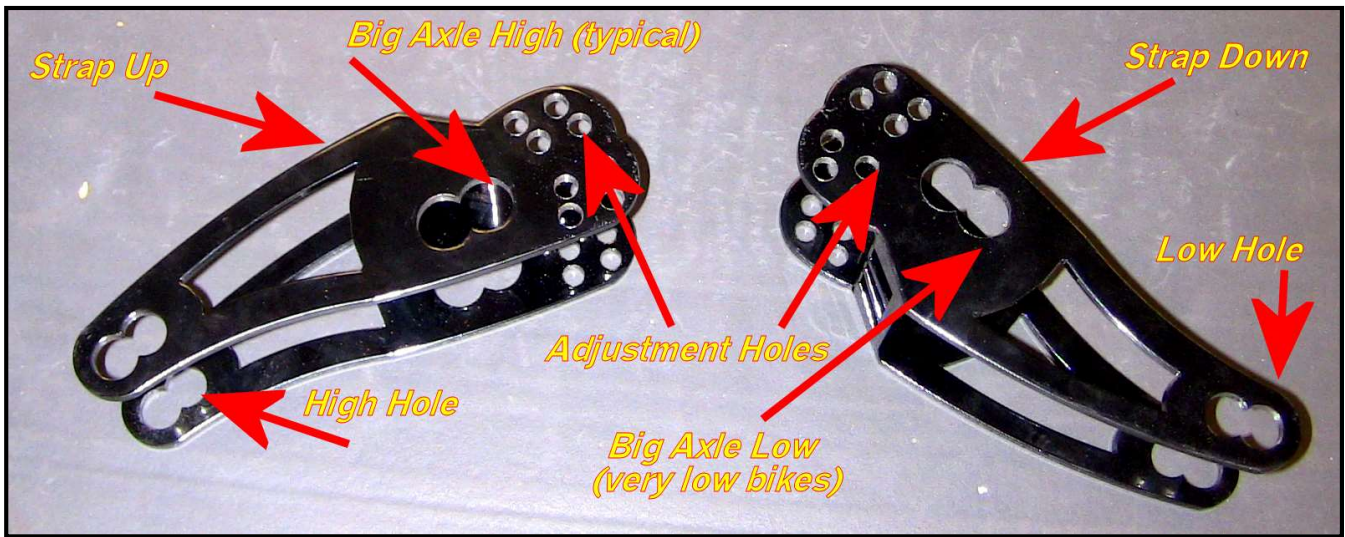

Above you can see the wheels reversed from the left picture to the right. Notice the curve is different. The right one is shorter than the left (shorter is what bikes that are a bit lower require!).



At left is a picture that shows the angle of the actuator when the wheels are set properly. Notice the bottom of the cylinder (silver, inside the black legs) is further forward than the top! Yours should look like something like this.

If you are still not getting the stability we describe here, please call us, and we will try to determine why not (407-834-5007).

TEST RIDE

PLEASE NOTE: Immediately after turning on your bike (within 5 seconds), the top light on the handlebar control will flash for a few seconds. This is the system either making sure that no air is in the legs if they are up (for safety it makes sure air does not build up when the legs are in the up position), or that the proper amount of air is in the system if they are down (again for safety to make sure the legs stay pumped completely!). This test occurs once a minute for all the time the bike is powered up, whether you turn the LegUp system on or not!

Get the bike to a clear paved mostly level area where you can test ride it. Start the bike, turn on the LegUp system and lower the legs. The first test should be done in a straight line. Put the bike in gear and slowly accelerate. You may notice that the bike tends to want to steer a small amount left or right. This is normal unless it is severe. Effectively, you are driving a trike, and steering is done with the handlebars **NOT** by leaning. Once underway, (we recommend you keep your thumb near the left button, and press it to raise the wheels if there are any surprises) the top LED should flash at around 6 MPH, meaning the legs are retracting. It is difficult to lean on one wheel or the other as you leave, so you may wish to raise the wheels manually if the bike is steering due to uneven pavement.

Assuming the legs are retracted, you should try to deploy the wheels. As you come to a stop, the Green LED should be on. As you slow down (**almost stopped**), the Yellow LED should illuminate at the proper speed. Once it does (sometimes hard to see), hit the left button and put your feet down near the ground. The top LED should flash and the wheels should deploy almost instantly underneath you! Make sure you are ready to balance the bike, though you likely won't have to! Immediately after the wheels touch the ground, the bike should be supported reasonably, but the cylinders can take up to 6 seconds to get completely filled. Make sure you balance the bike as this occurs. The slower you are going when deploying the wheels, the smoother the transition will be from wheels up to wheels down. Practice these maneuvers until you are comfortable with the wheel adjustments and the system operation.

NOTE: With the system on or off, if the legs are up, the computer will dump the air from legs once every minute that the bike is turned on! This is a safety feature to make sure pressure does not build inside the legs, causing them to deploy! The top light will flash once a minute for a few seconds. This is completely normal, and the left button will be inoperable while this occurs.

SEMI-AUTOMATIC DEPLOYMENT: Another way to deploy the legs is semi-automatically. First we must be **SURE** that the proximity sensor is working properly or the wheels could come down at higher speeds than we wish. If you are travelling at a speed over 10 MPH, AND the yellow light (bottom) on the handlebar control is out, hit the left button. The bottom or yellow LED should start to flash. When you slow down to around 5MPH the wheels will deploy (see the red/green flash on top LED). Again prepare to put your feet down. IF the lower LED is lit at a speed over 10 MPH, don't hit that button; see caution below!

NOTE: The bottom LED Should not be LIT SOLID if the bike is travelling over 10MPH! In the event it is, the wheels will deploy instantly if you try to set them as above; this is dangerous! You MUST re-visit the sections on testing the proximity sensor. You should always be aware that this light should NOT be on if you are traveling at speed, and 'Arming' the system for deployment should only be attempted if the lower LED is Not Lit! Please see the User Manual for more information on Proximity Sensor Failure!

The next thing to try is to make a turn from a dead stop with the wheels down. As soon as you start the bike moving, turns can only be made by using the handlebars. The LegUp system is too strong to allow a great deal of lean with the wheels down! If you need to make a turn shortly after departing from a stop, raise the wheels manually (left button) and you will get complete control again.

The next thing to try is slow speed maneuvering with the wheels lowered. If you keep your speed down, most slow speed maneuvers can be accomplished with your feet up, keeping in mind that at about 6 MPH the wheels will come up automatically! You can try full lock turns in both directions and the bike should stay upright with your feet up.

Understand; it is always a good idea to keep your feet near the ground during these maneuvers if you can. A mechanical failure or a wheel in a pothole could upset the bike.

Because the wheels are right behind your legs when they are down, we recommend not trying to push with your feet to move the bike forward. Use the engine and keep your feet out of the way; this way the legs don't bite at your heels as the floorboard always have! Backing up using your feet works fine and the chore of balancing the bike is taken care of for you.

Practice, practice, practice!! Enjoy your LegUp System!

ILLUSTRATIONS

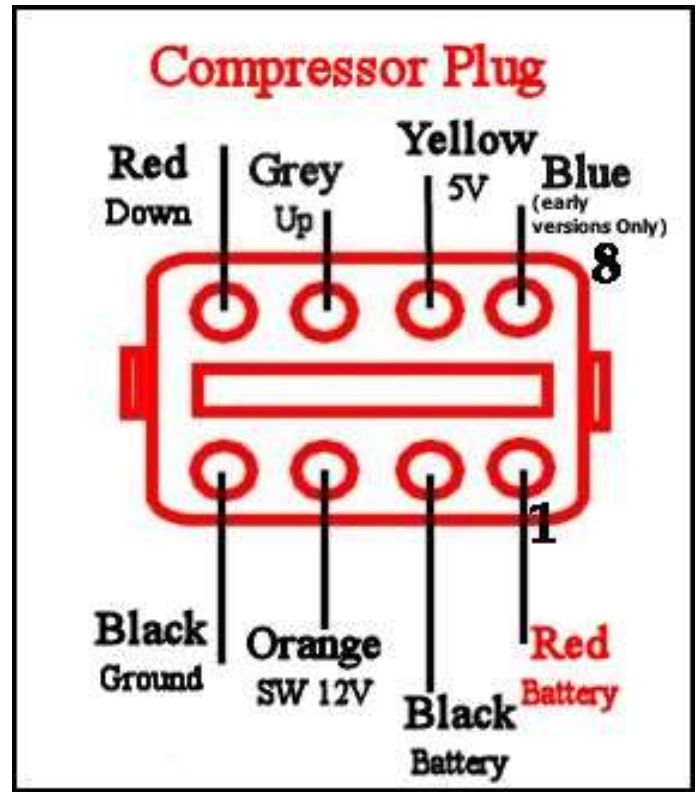
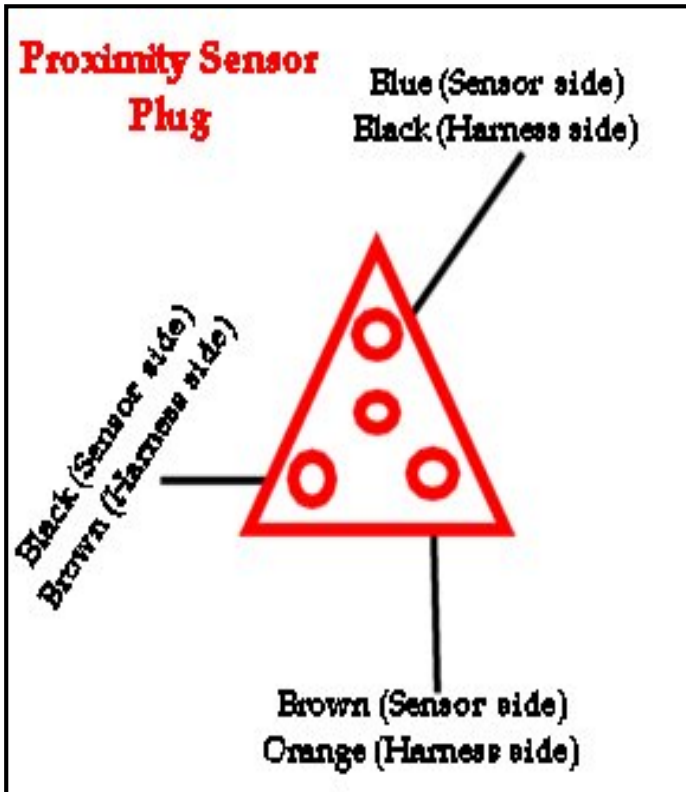

Due to global distributions problems, we may have to use a four pin plug instead of a 3 pin plug. The colors still need to be the same across the plugs with pin 4 empty!

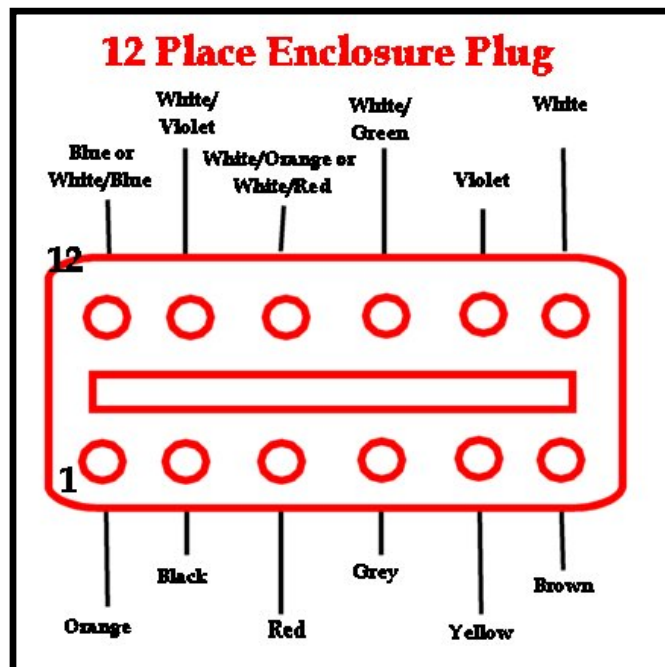

HARDWARE LIST

(4) 3/8-16 X 2 1/4" Allen Head Bolts (Mount Legs)

(4) 3/8 Flat Washers (For Spacing)

(2) 3/8" X .75" Aluminum Spacers (Mount Legs)

(1) 3/8" X 3/8" Aluminum Spacer (Mount Legs)

(1) Softail Chrome Floorboard Kit

(1) 10-24 X 2 1/4" Stainless Allen with Spacer (7/8"X3/8", Mount for Handlebar Switch no Bracket)

(2) 5/32" Black Air Line, 5 Foot Long (cylinders to saddlebag)

(2) 5/32" Black Air Line, 2 Foot Long (valves to unions)

(2) 5/32" Union Fittings

Big & Small Wire Ties, self-adhesive clips.

***** Use Long Wheel Holders set like FL with Wheel on High Hole. *****