



**US PATENT # 8,235,419 B**

**Installation Manual  
Generation II Harley  
Touring Models  
1988-Present  
REV B**

**Copyright 2016, Pete Giarrusso, Inc.  
D/B/A Chopper Design Services  
All Rights Reserved**



# Table of Contents

<b>INTRODUCTION .....</b>	<b>4</b>
<b>WARRANTY .....</b>	<b>5</b>
<b>INSTALLATION INSTRUCTIONS .....</b>	<b>6</b>
<b>PREPARE FOR INSTALLATION .....</b>	<b>7</b>
<b>CONTROL SWITCH BOX .....</b>	<b>8</b>
<b>WIRING HARNESS .....</b>	<b>10</b>
<b>SWITCHED POWER FOR 2021-UP .....</b>	<b>13</b>
<b>LEG &amp; MOUNT ASSEMBLIES.....</b>	<b>14</b>
<b>RUNNING AIR LINES.....</b>	<b>17</b>
<b>SADDLEBAG PREP (HARD BAGS).....</b>	<b>19</b>
<b>EXTENDED SADDLEBAG SPACER.....</b>	<b>21</b>
<b>SADDLEBAG PREP (SOFT BAGS).....</b>	<b>21</b>
<b>INSTALL THE COMPRESSOR (HARD BAGS).....</b>	<b>23</b>
<b>INSTALL THE COMPRESSOR (SOFT BAGS).....</b>	<b>24</b>
<b>MOUNT PROXIMITY SWITCH.....</b>	<b>27</b>
<b>BIKES WITH PULLEY BOLTS.....</b>	<b>27</b>
<b>BIKE WITH NO PULLEY BOLTS (CUSH-DRIVE).....</b>	<b>28</b>
<b>WIRE ROUTING.....</b>	<b>30</b>
<b>FINISHING UP.....</b>	<b>32</b>
<b>FINAL ADJUSTMENTS &amp; MAINTENANCE MODE .....</b>	<b>33</b>
<b>MAINTENANCE MODE.....</b>	<b>33</b>
<b>WHEEL ADJUSTMENT .....</b>	<b>34</b>
<b>TEST RIDE .....</b>	<b>39</b>
<b>GENERATION I UPGRADE INSTRUCTIONS.....</b>	<b>41</b>
<b>ILLUSTRATIONS .....</b>	<b>42</b>
<b>SADDLEBAG DRILL TEMPLATE (HARD BAGS) .....</b>	<b>43</b>
<b>SADDLEBAG DRILL TEMPLATE (SOFT BAGS).....</b>	<b>43</b>
<b>HARDWARE LIST.....</b>	<b>45</b>

# Introduction

This manual covers installation of the Generation II LegUp LandinGear system by Chopper Design Services. This system should only be installed by a qualified technician, or those with above average mechanical skills. If you are not **SURE** that you can perform this installation, please contact us and we will help you find a qualified shop to assist you.

While the Generation II System holds your bike upright very well, you are **STILL** responsible for balancing the bike! The system **WILL** relieve you of some of the weight of the bike and help you avoid balance problems as you approach a stop, maneuver at slow speeds, and back the bike up.

Improper installation will void your warranty, so please be very careful!

Thanks for choosing LegUp!

# Warranty

Chopper Design Services warrants the LegUp system for a period of one year from date of purchase. This warranty covers replacement parts and/or manufacturer defects. Incidental damages or costs are the responsibility of the purchaser.

Defective parts are to be returned to Chopper Design at the address below. Purchaser must contact Chopper Design to receive a Return Material Authorization, prior to returning defective parts to Chopper Design.

Abuse, improper installation or use, collisions or accidents, are not covered under this warranty. Replacement parts for this type of damage are available through Chopper Design.

Users of the LegUp system agree that Chopper Design is **NOT** responsible for personal injuries or damage to property arising from the use of the system. While we believe this system to be safe and reliable, the user is advised that use of LegUp is done so at the users' own risk. Use of the system implies agreement to the above statements. If you can't agree with the above, Chopper Design and its dealers would be happy to refund your full purchase price, before you install the LegUp System.

Chopper Design Services  
1365 Bennett Dr. #101  
Longwood, FL 32750

407-834-5007  
[LegUp@LandinGear.com](mailto:LegUp@LandinGear.com)

# Installation Instructions

The LegUp® system has many components. Please be sure you have them all before starting your installation.

## COMPONENTS:

- 1) **Wire Harness W Switch Box**
- 2) **Leg and Mount Assembly (L/R)**
- 3) **On-board Computer Module**
- 4) **Proximity Sensor**
- 5) **Saddlebag Mounted Compressor System**
- 6) **Hardware Bag**

If you believe you are missing any parts, please contact Chopper Design at 407-834-5007, and we will rectify the situation. Some of the parts are shown below.

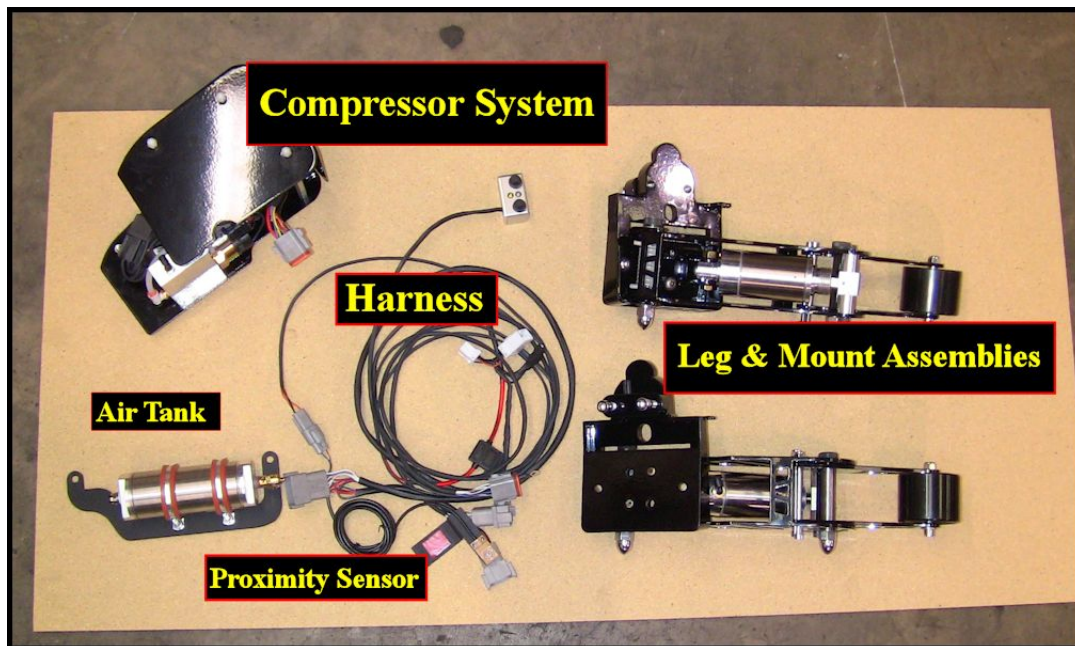

# PREPARE FOR INSTALLATION

***IF YOU ARE UPGRADING FROM A GENERATION I SYSTEM, PLEASE READ THE ADDENDUM TOWARD THE END OF THIS MANUAL ON THIS SUBJECT FIRST!***

*Please do not let the size of this manual intimidate you. We cover many different bikes and circumstances here, and we feel that more pictures and more detail can only help someone trying to install our systems. Better to have the details than want for them!*

Place the motorcycle on an acceptable bike lift. You will need to keep the bike on its wheels for most of the installation, and jack the rear wheel off the lift for some portion of the installation. Make SURE the motorcycle is secure on the lift!

Remove the seat and disconnect the negative cable on the battery.

This manual is available at <http://landingear.com/pdf/g2installhdf1-REVB.pdf> . It may be easier to see some of the pictures in color there!

We are now ready to begin!

# CONTROL SWITCH BOX

***NOTE: ON pre 1996 models as well as 2014 and up models, you will need a bracket to mount the switch housing, which we should have supplied. In this case, remove the bolts that secure the clutch perch clamp on the left side, install the supplied bolts through the bracket that has the box mounted to it, through the supplied spacers, and into the clutch perch (Blue Loctite here). Once tightened, follow the rest of these instructions.***

If your bike requires no bracket as mentioned above, remove the bolt on the top of the left switch housing on the handlebar. Find the long chrome bolt, thread it through the Control Switch Box, insert the spacer on the bolt and (with a drop of Blue Loctite), and thread the bolt into the switch housing. Square the box before tightening the bolt (you may have to re-align the mirror for clearance).

Route the wire inside the clutch lever and down the bar. Use wire ties to hold the wire to the bar. Run the wire through the top triple tree if you can to control it. The idea here is to get the wires neatly to the front of the tank and routed under the tank. (It may be easier to remove the plug end and tape the silver plug ends together for this). We have some pictures below to give you an idea of what this looks like.



On some bikes it is easier to loosen or remove some of the tank mounting bolts. Make sure the wires do not interfere with anything under the tank, and that there is nothing that would scuff the wires.

Once the wires are under the seat area, you can assemble the plug, if disassembled, according to the diagrams on the next page.

Some folks will have a 6-pin plug and others will have the 8-pin version. More mistakes occur putting these plugs together than anything else. The pins are pushed through the rubber holes into the plug until they click. The pins need to be completely flush with the edge of the plug. Then the insert is pushed



into the opening. The wiring details are found on the next page. Be VERY careful to get the wires in the correct hole; all the colors match to the mating plug!



# Pin Out for Handlebar Control Box Plugs

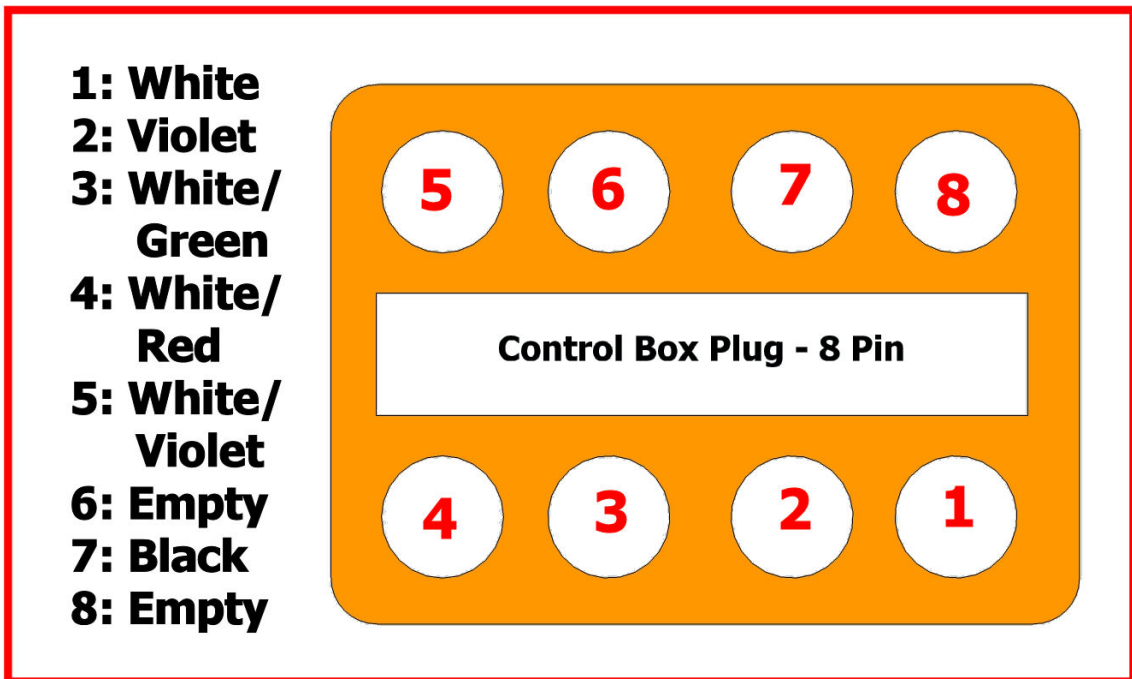
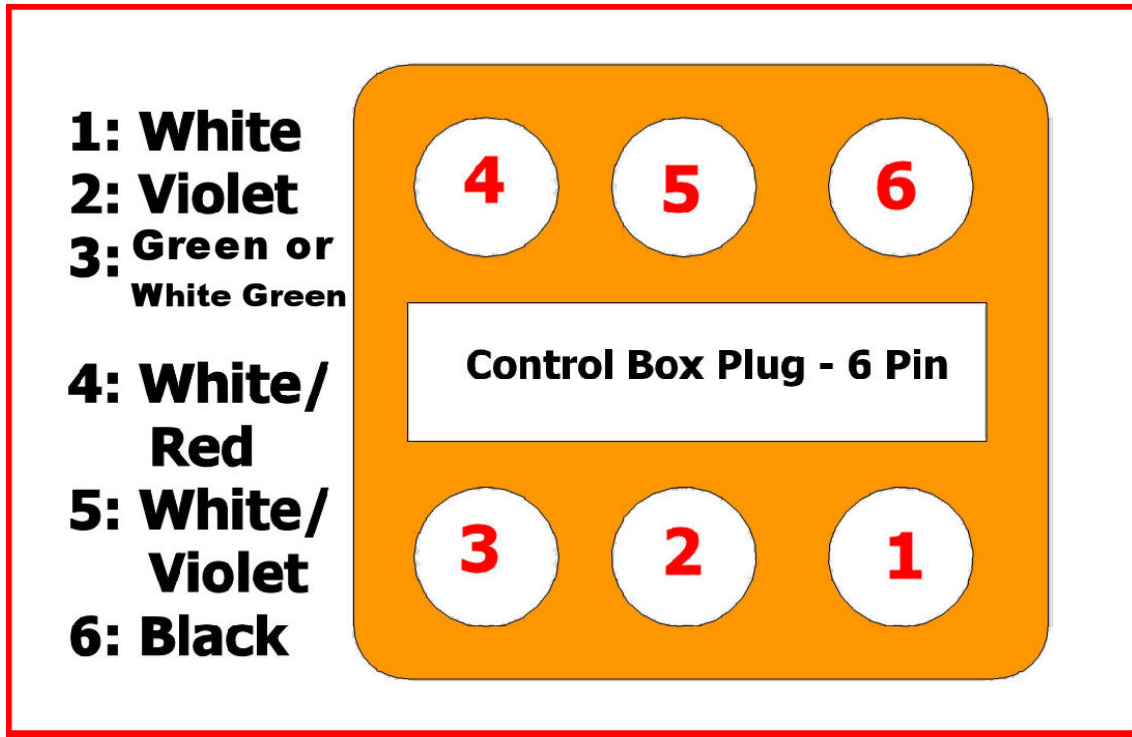

# WIRING HARNESS

***NOTE: If you are upgrading your existing Generation 1 system, please read the addendum on this upgrade at the end of this manual, before continuing with the wiring harness.***

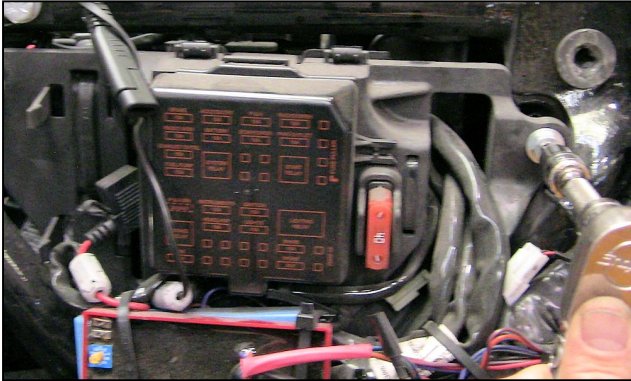

The next step is to route the wiring harness. The harness and the plugs are routed mostly under the seat. Different models have different amounts of space in this area, and all the wires are long enough to allow you to place the connectors in the best place for your bike.

Remove the left side cover & saddlebag. We need to make room for two big plugs to come through the seat area toward the left saddlebag. On later model

bikes, this means removing the Torx bolt that holds the fuse box under the left side cover. On earlier bikes there is more room in this area and nothing needs to be removed.

Find the two BIG plugs on the harness (12 pin with an 8 pin pigtail attached), and slide them through the seat area, and out just below the left fender support. Leave the remainder of the wire harness under the seat for now. Once both plugs are through, you can pull most of the slack out. We will be pulling these plugs back toward the rear of the saddlebag, behind the shock.

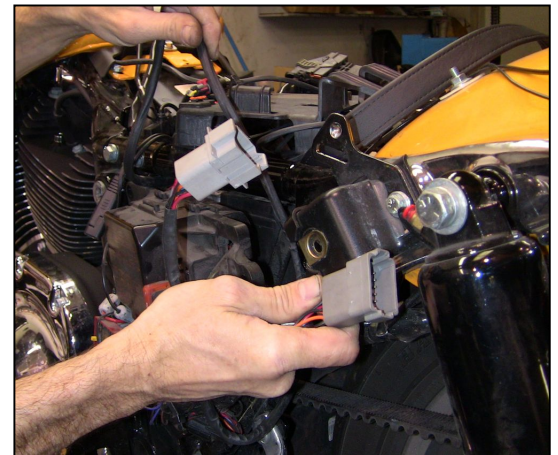

The plug from the Proximity Sensor (3-wire) needs to be routed under the seat as well. If you have Pulley bolts on the drive pulley (07-earlier) bring the plug up on the left side (where the big plugs just went through). If you have a Cush-Drive bike (08-later), bring the wire up through the right side cover and under the seat. At this point just route the wires into the general area and plan where you would like to tie them up safely. The Proximity sensor is not mounted yet because we need to have power to make sure it is placed perfectly, so just route the wire for now. You can collect any excess wire under the seat area, when the time comes.

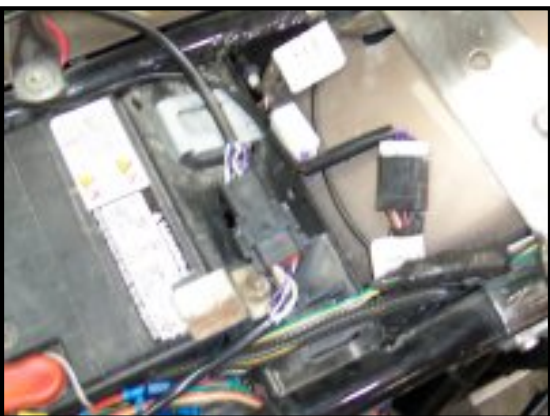

On 08-earlier bikes, Disconnect the fender plug under the seat, and plug the double white plug in-between the plugs from the bike.

On 2009 – 2013 bikes, some of the fender plugs are not like the one shown here, so we plug into the 4 pin Deutsch accessory connector instead, found under the seat, in front of the battery. Remove the rubber plug and plug the harness plug (with just two wires; orange/black) into this connector. The double white plugs we talked about above will NOT be found on your harness.

***NOTE: If you have something plugged into this connector already, you will need to get a ‘Y’ connector from Harley (Part #70264-94A).***

Similarly, 2014-Up bikes don’t have the same fender plug either, so we supply a 6 pin Deutsch plug to mate with the Diagnostic Plug under the left side cover. If you have this 6-pin plug with an orange and maybe a black wire, great. If instead you have a double black plug (like the 2021-up), refer to the next chapter ‘***Switched Power for 2021-Up***’.

***NOTE: This 6-pin plug has 2 wires (sometimes just one... Orange!); don’t confuse it with the 6-pin plug that connects to the handlebar plug you recently assembled that has 6 wires in it!!!***

We will supply you with the plug for your bike; you just have to find where the factory hid its mate.

***NOTE: If you have a pre-1996 bike, you will have two wires (no white plug) and will need to connect these to switched 12-volt (orange) and ground (black). If there is no black, no worries; we have some harnesses that have 2 black wires attached to the battery, eliminating the black wire on the branch that has the orange wire. If this is the case, you only have to attach the orange wire to a switched 12 volt source.***

***NOTE: 2021 need special handling; please see the next chapter titled: ‘Switched Power for 2021-Up’***

Connect the Control Switch Box plug to its mating connector under the seat (8 pin or 6 pin as previously discussed), and plug the proximity sensor plug into its’ matching connector.

We need to find the fuse holder and the black wire with the hoop ends and get them to the battery. These two wires run direct power to the compressor when it needs it.

This wire should already be under the seat area. We want to connect the wire with the fuse holder to the positive terminal of the battery (the battery cable should attach closest to the battery with this connector and any others attached after the battery cable, as shown here). Plan where you want the fuse holder so you can get to it if it is ever required!

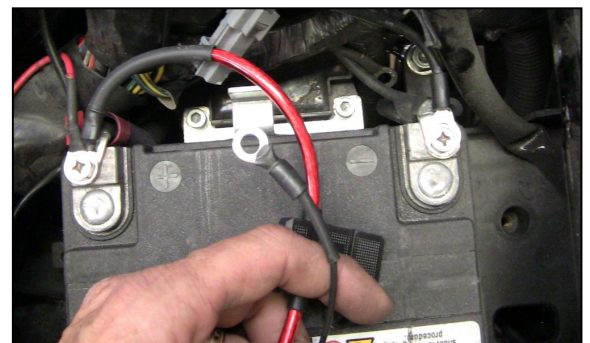

Don't connect the black wire to the negative post yet! We will when we are ready to test the system. Depending on the year of your bike, it may look very different than the picture here.

Don't tie down the wires just yet; we will clean up everything later. Also, leave the left electrical box loose (if applicable) until later as we will need to run air lines in this area.

Next, we need to secure the wires that go into the saddlebag to the left fender rail, and leave enough wire for the plugs to reach the computer and the compressor.

Start by getting the wire with the 2 big plugs on it, run inside the left shock toward the back of the bike. Next, measure 10 inches back from the 12 pin (biggest) plug and mark the wire. We are trying to make sure we have all the wire we need but not too much extra.

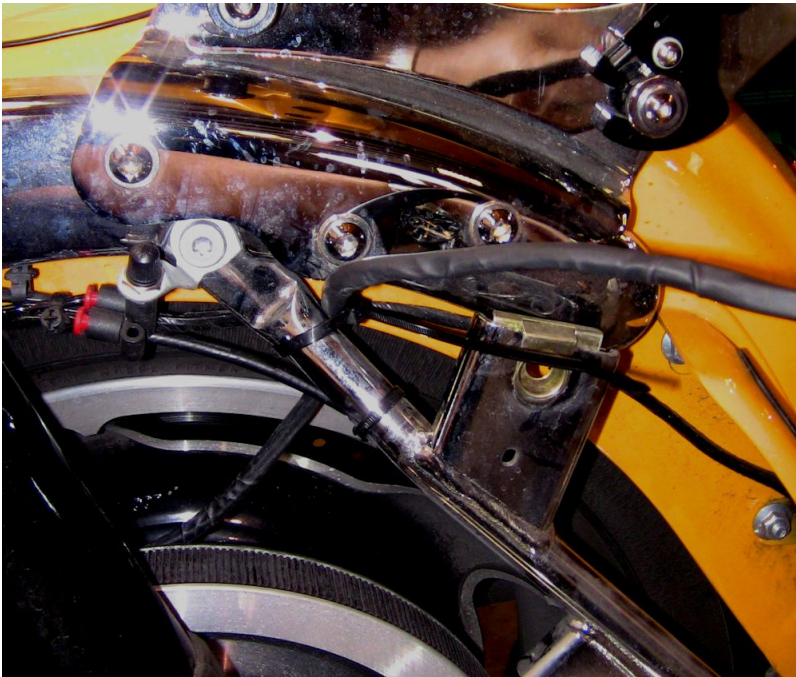

Run the wire under the chrome fender support and tie it off to the two fender supports. 2009 and later bikes look like the picture at left, on others it will look a bit different; just make sure you leave the wire needed, and tie it off securely and out of the way of anything that moves or could hurt the wire.

No Matter how you need to secure the wire, make sure you have 10 inches of wire sticking out from the end of the fender support, to allow us enough wire to get what we need into the saddlebag.

You can now pull the extra wire back into the under seat area. Later we will be securing air lines to this wire, so make sure that will be possible with your choice of how to attach this wire!

The only wire left dangling should be the proximity sensor and mount, and we will handle that soon.

# SWITCHED POWER FOR 2021-UP

Harley, in 2021 eliminated the plug we used for the last 10 years to supply power to our systems. We have had to resort to grabbing power from the Fender plug for 2021-Up models.

***NOTE: Due to supply chain problems, we have had to supply this plugs for some 2014-2019 models as well!***

First, find the double black plug under the seat near the fender. It should look something like the picture at right, although some models may have a pair of plugs, one tan, and one black. You will need to unplug the black plugs and find our double black plug on the end of a thin wire on the harness.

Plug both ends of our harness plug into the black plugs. This will pass all circuits through to the fender and allow us to have the switched 12 Volts we need on the accessory circuit.

Plug both ends of our harness plug into the black plugs. This will pass all wires through to the fender and allow us to have the switched 12 Volts we need on the accessory circuit.

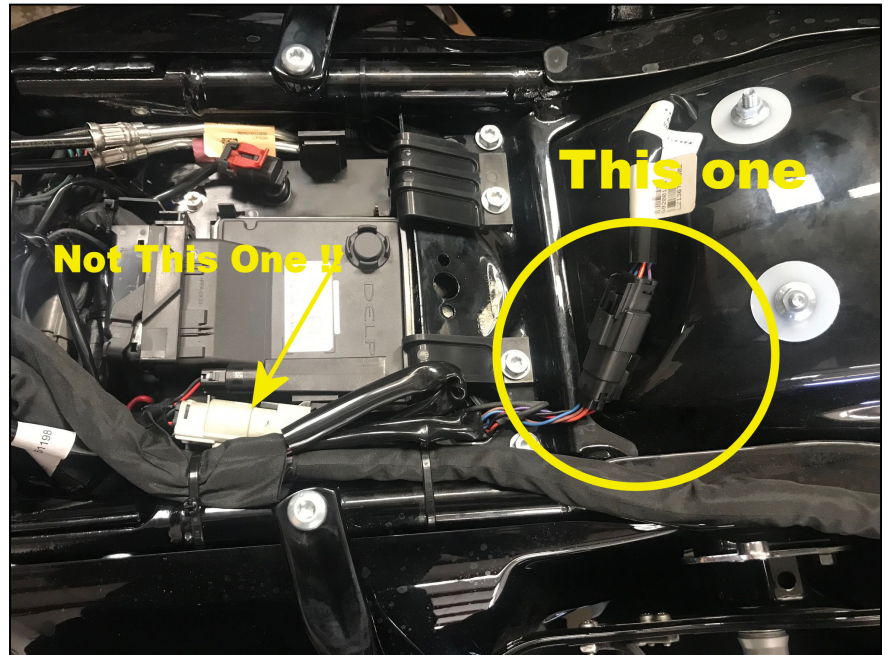

When you are finished it should look something like the picture here; just make sure placement does not interfere with the seat when reinstalled.

Now back to our regularly scheduled install!!

# LEG & MOUNT ASSEMBLIES

**IMPORTANT!** *This manual covers our Rev B Mounting system, which replaces the stock passenger single bolt design with our own, two bolt mounts. If you have the earlier mounting system that clamps to existing floorboards, please see the link below for the correct manual for your application:*

<http://landingear.com/pdf/g2installhdf1.pdf>

First we want to remove the passenger floorboards (if installed). If your bike had pegs, you can buy floorboards from Harley or we can supply them to you (skip to the next page!). If you have floorboards, it is easier to remove these while the mount is still on the bike!

As shown at right, lift the inboard part of the floorboard cover, which exposes (2) pins, and soon a ball-bearing and a spring. The arrow shows Ben pushing one of the pins toward the center. Do this on both sides, but keep pressure downward on the board to maintain the ball-bearing and spring that is beneath it in the middle. Once this is done, carefully raise the board off the mount, catching said spring setup, and set the board & hardware aside for installation later.

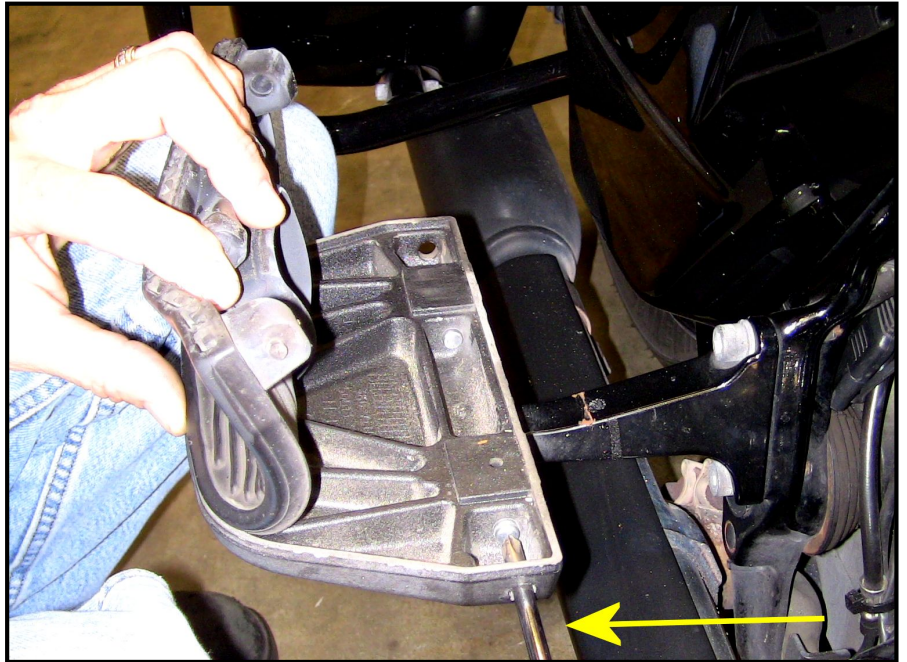

In order to mount the legs in place of the passenger floorboards/pegs, we must remove the existing rear floorboard or pegs mounts, whichever the bike is using. Depending on the year, the bike will have one or two Allen bolts holding the now exposed mount to the bike. Once these are removed, make sure the top and the 3<sup>rd</sup> hole from the top do **NOT** have any plastic plugs in them.

We are now ready to mount the Legs.

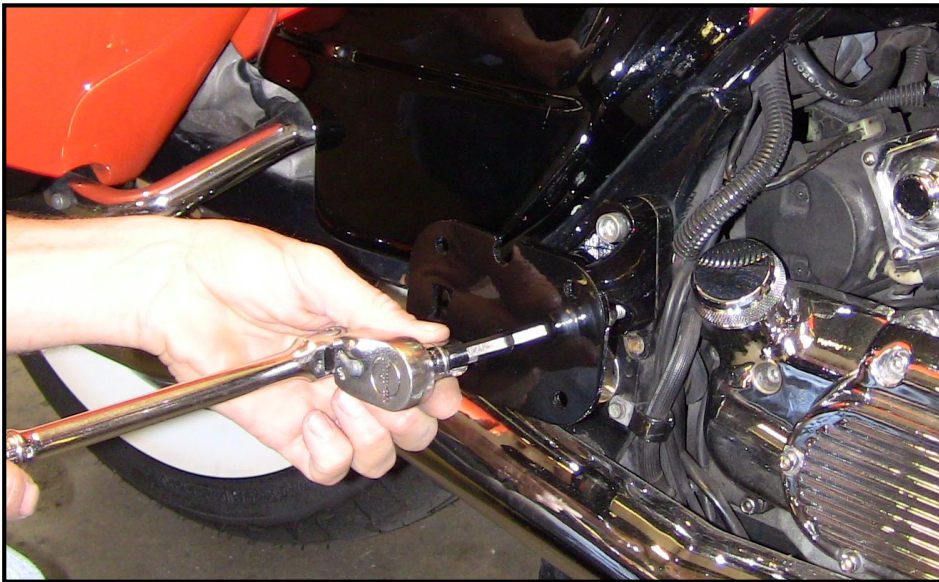

Each leg has two pieces; we have a mount that attaches directly to the bike and a leg that mounts to this piece. This new mounting system is **MUCH** stronger than Harley's floorboard mounts.

Find the mount as shown at left, and (2) 3/8X1" Allen head screws. Put a touch of Red Loctite on the threads of the screws and mount the bracket to the bike (**The letter 'L'**

**should be readable, not upside-down... The 'L' is on BOTH Pieces... The two parts are identical... The 'L' does NOT stand for 'LEFT'**). We are using a long, ball-end Allen bit through the holes in the plate, but a hand Allen wrench can work just as well. These bolts need to be very tight, because it is difficult to get to them once the leg system is installed.

Next we want to attach the leg system. First gather 2 5/16-18 X 7/8" button-head bolts with Nylock nuts and (2) 5/16 X 7/8" Hex Head bolts with Nylock nuts. Make sure you have the correct leg, raise it up to the plate you just mounted and insert the button-head bolts into the top holes. This should support the heavy leg system. Install the two Nylock nuts to these bolts (Ben is shown tightening the top bolts at right). Do NOT get these very tight quite yet!

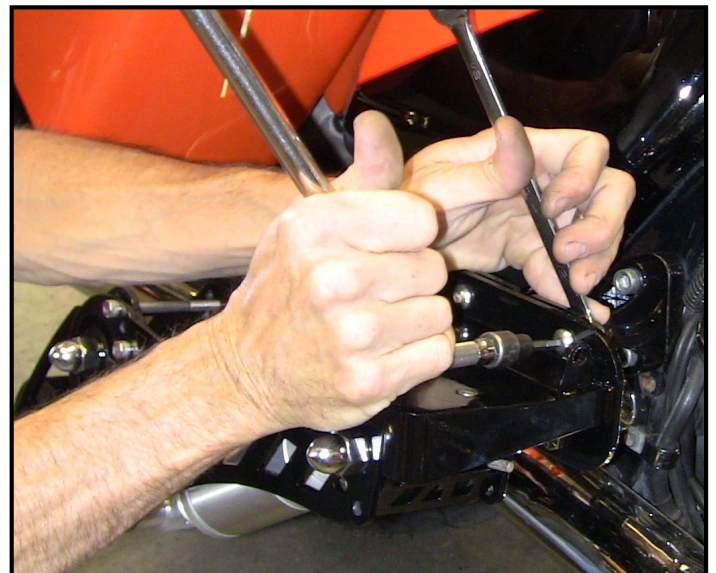

Now install the two hex heads into the lower holes. If you have trouble getting to the back

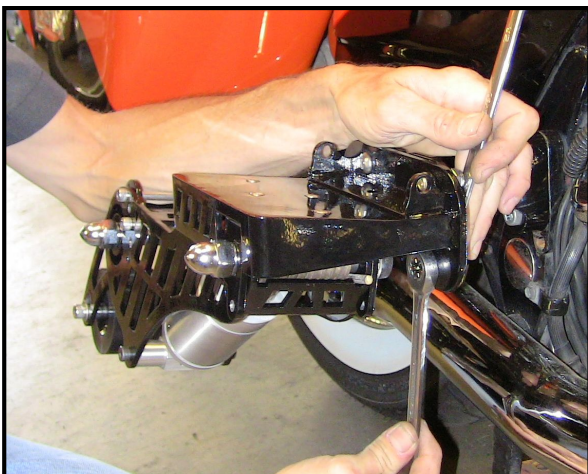

hole, get the front one in place first, with its nut attached, then you should be able to pull the leg down to line up the back bolt. Once all the bolts and nuts are in place, slowly snug them all down. Two 1/2" wrenches are used on the bottom bolts as shown here.

Once you have the bolts completely tight, give the leg a good tug; it should be one with the bike!

Let's mount the floorboard!

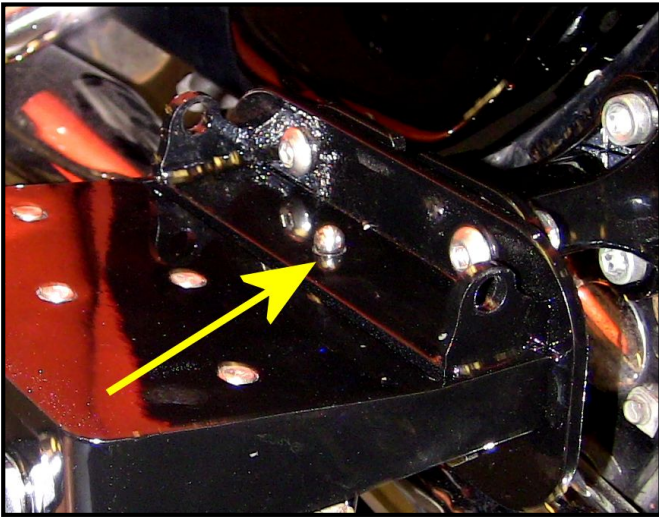

At left, you can see the leg system mounted. The arrow points to the installed spring and ball-bearing. Make sure this is in place and offer up the floorboard carefully to this mount.

Just like when we removed the floorboard, we want to slide the pins in to hold it in place. Have a small screwdriver or something that will allow you to push these toward the middle, through the holes on the outside.

Carefully lower the board onto the mount, being careful not to disturb the spring or ball-bearing.

Once in place, push each of the pins through the board and the mount holes on the leg system until they have about  $\frac{1}{4}$ " showing on both sides of the floorboard casting. You will know you have the correct amount if the floorboard cover can fall back into place. If not, make small adjustments to the pins to center them, and make sure the floorboard cover sits back down nicely.

Please Note: The floorboards on our mount only flip a small amount. This allows cleaning if/when needed. We would have had to make the mounts a bit wider and higher to allow the boards to flip up. We felt this was unnecessary due to the fact that our leg mounts are fixed in the same spot the floorboards occupy when they are down.



Make sure the rubber is flat and stuck in the down position. Let's run the air lines.



# RUNNING AIR LINES

We need to route the air lines from the cylinders to the area near the left saddlebag. You should find 2 long air lines of identical lengths. On the right side of the bike, press one end into the fitting on the back of the air cylinder. These press in relatively easy, but a small tug will make sure the line is seated.

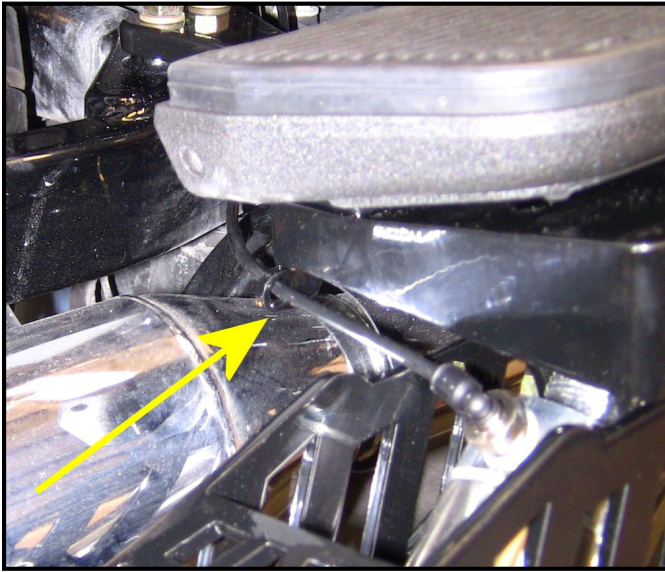

Guide the line through the hole in the mount as shown by the arrow at left (all styles have a hole for the line); picture may not show your style board. We now need to guide that line over to the left side of the bike as we will be running it with

the other line, away from anything that might damage it!

At right we have a picture of the line running under the right floorboard mount, tied lightly to the floorboard mount (Notice Ben is extending the leg, so he gets the needed slack from the line) and run under the right side cover area to get to the other side of the bike and joining the left line. Get the line there any way you can, just be sure that it is secure, and cannot be damaged by anything hot or moving. Once run, you should mark the end with masking tape as **'RIGHT'**.

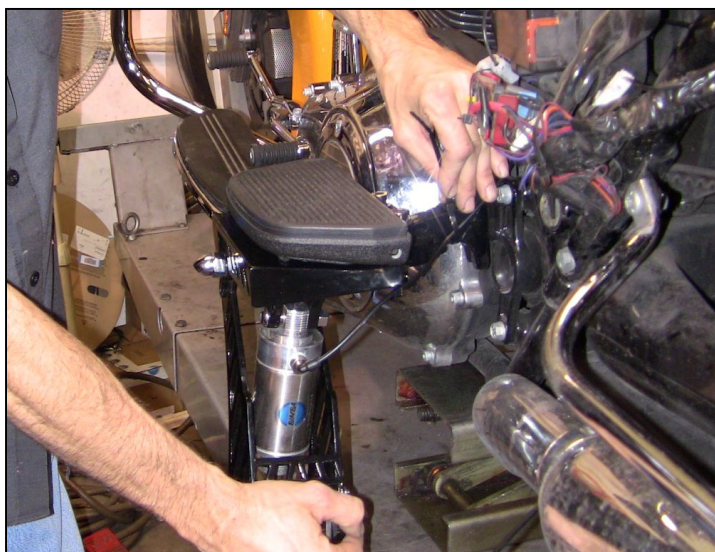

Take the other line; insert it into the left cylinder as you did on the other side. Mark the far end as **'LEFT'** and tie the marked ends together with masking tape, so we can run them together.

Check Both Sides before we move on that by lowering and raising the legs, there is plenty of slack for the lines. Readjust your wire ties if need be, but make sure they work properly to avoid headaches later!

We want to run the lines behind or through the area under the left side cover. Here Ben ties the two together on their way toward the back. We want to guide these up to where the wire running along the fender support is. We like to tie two loose wire ties to that wire, and run the air lines through them. We will adjust and tighten everything a bit later.

The main concern here is to make sure the lines are run where they will be safe from the belt, exhaust pipes, or anything that could hurt them.

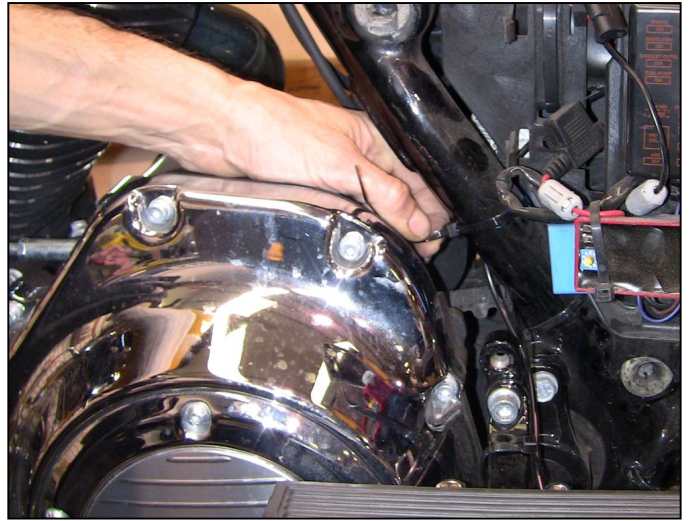

Here is a picture of the lines running along the bottom of the fender support, being tied off to the big wire running toward the back. You can tie them to anything you like, as long as they are safe and out of the way! Then you can start working back tying off the lines. Tighten the lines under the fender strut, and just leave the end wild for now!

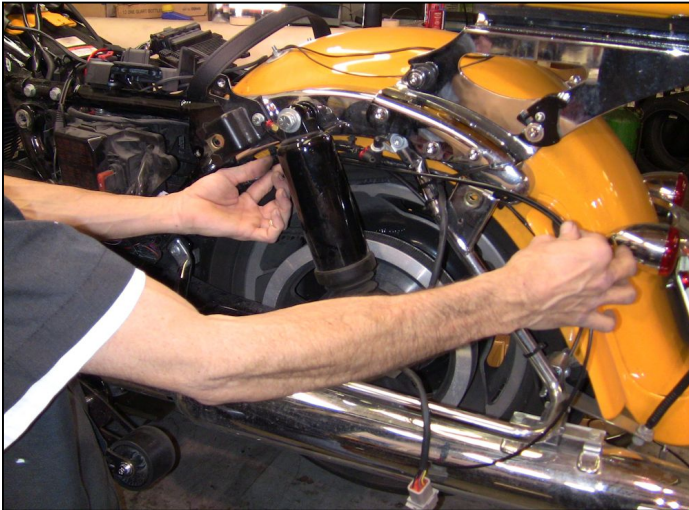

**These are air lines, so tie them off snugly. Careful though; too tight could restrict the air flow.**

Once we have everything tied up, we want to make a loop with the extra line. This will keep the lines the same length (which allows the wheels to come down evenly) and makes it

easier to remove and install the bags. Just take the lines as shown here, make a nice loop, and tie them off to each other. Not too tightly as we want the loop to be able to move as you try to remove or install the bags.

Next we want to prepare the saddlebag. This requires us to drill a few small holes to allow lines or fittings to travel through the bag to get to the compressor system.

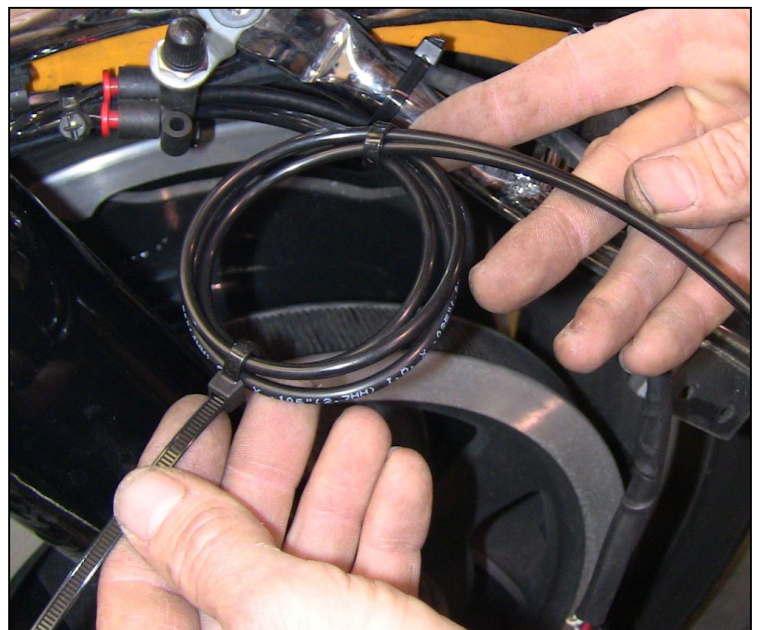

# SADDLEBAG PREP (HARD BAGS)

**NOTE: If you have soft bags (Road King Classics and Customs), skip to the next section; 'Saddlebag Prep (Soft Bags)'.**

On one of the last pages of this manual, you will find a drilling template for Hard Bags. Carefully cut the template out (making sure it is to scale), and tape it to the inside of the left saddlebag as shown. The saddlebag is curved, so just bring the straight lines to the edges where they start to curve and you will be fine. There is a margin of error here, so don't worry!

Use a small bit to start (1/8" or so) and drill through the pilot hole on the template. Once these are done, the final drill size is 3/8" or 1/2" depending on the fittings (we supply 2 different sizes from 2 different vendors). If you are unsure, drill a 3/8" hole, if it is too small, move up to 1/2".

Once the holes are in place, find the bulkhead fittings. The 90 degree part stays on the outside of the bag with the straight part inside.

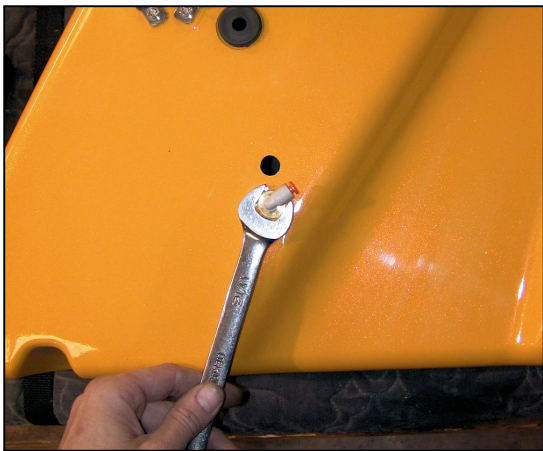

Start with the lower hole, and tighten the fitting. No reason to make it too tight; there is no chance for leaks here, and the elbow spins to make it easier to attach the lines.

Once the bottom fitting is in place, install and tighten the top fitting. Now the bag is ready!

It is time for a test fit! Put the saddlebag on the rail and lean it out as shown here. Find the line you marked as

right, and insert it in the bottom fitting; the other in the top fitting. Now attach the bag, and make sure the lines are in no sort of bind or in danger of being damaged by anything!



The last thing we need to do is create a small notch for the wires to get through when the bag is closed. We use a rotary burr, but you could use a file or a small saw, to cut the notch you see here.

What we want to have is a notch about 3/8" wide by about 3/8" deep. This small slot will have no negative bearing on the weather-tight nature of the bag, but it will keep the wire from being hurt as you open and close the bag over time.

At the top of the bag, about 1" to the left of the bail nut (the bolt that holds the bag on) is where you want to place the relief. A bit left or right makes little difference, but this wire goes down into a relief cut in the top of the compressor cover, so the more accurate you are here, the better!

Make sure that the wire, when placed into the notch, is at or below the top surface of the bag, and you are good to go!

Unless you have Extended bags, skip the next 2 sections and go to **'Install the Compressor (Hard Bags)'**.



# EXTENDED SADDLEBAG SPACER

***NOTE: If you have the new extended bags, the rearmost portion gets longer toward the back. We now offer a spacer that will allow your compressor to sit level without having to stuff tee shirts under it!***



Shown here is the optional 'Extended Bag Spacer'. This spacer has 2 feet (right) and a tab (left) that sits in the bag to allow the compressor to sit just as it does in non-extended bags.

The spacer is just placed as shown here where it basically is wedged lightly in place. No fasteners are required; just place the spacer as shown, and install the compressor as shown in the picture below.

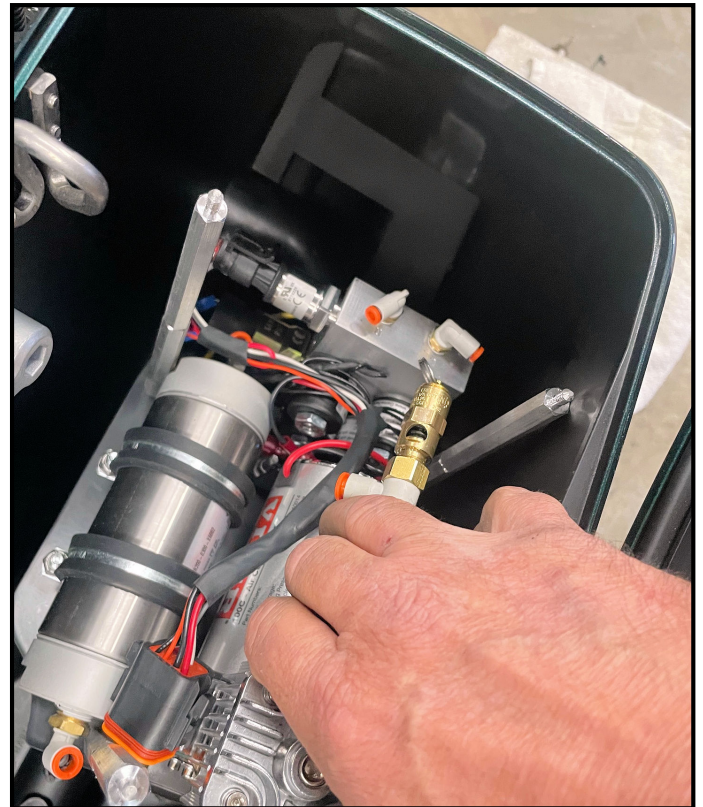

# SADDLEBAG PREP (SOFT BAGS)

**NOTE: If you have hard bags (all but Road King Customs & Classics), skip to the next section; 'Install Compressor (Hard Bags)'.**

On bikes with Harley® soft bags (Road King Customs & Classics), we used to mount the air tank outside the saddlebags, due to how narrow the soft bags are. Recently, we decided to use the compressor from the Softail® system, which has the air tank mounted above the compressor as you see here.

If you have the older setup, you can find the documentation at:

<http://landinggear.com/pdf/g2installhdf1.pdf>.

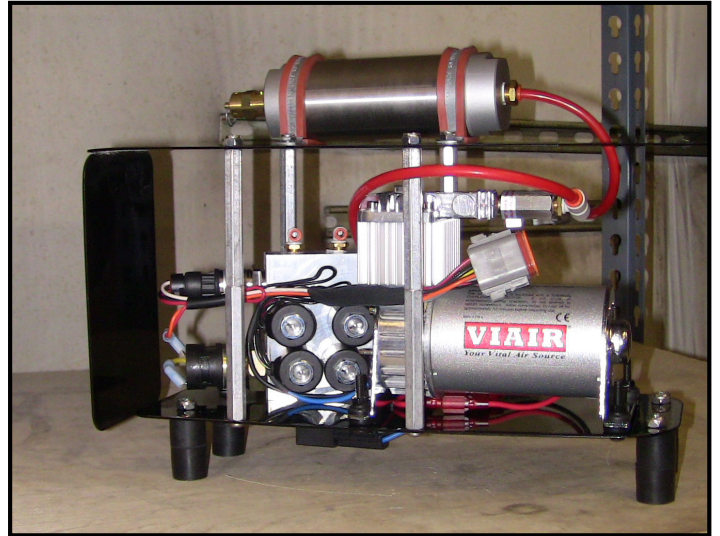

The only thing we need to do to prepare the saddlebag is to drill a required hole in the saddlebag back. The hole allows the air lines to get in and out of the saddlebag, and also allow easy removal of the bag.



First we need to find, near the end of the manual, the drilling template for soft bags. Carefully cut this template out, and tape it to the inside of the left saddlebag, as seen in the next picture. The flat bottom of the template lines up with the bottom of the bag, just before it turns under, while the curve should fit nicely as seen here. The upper left angle should fit inside the line where the leather meets the hard back.

There is a margin for error here so be careful but not paranoid. Once placed, drill using a 5/16" bit, **ONLY THE TOP** hole of the template. We used to use both holes when the tank was outside. Now skip to the section on installing the compressor (Soft Bags).

# INSTALL THE COMPRESSOR (HARD BAGS)

**NOTE: If you have soft bags (Road King Customs & Classics), skip to the next section; 'Install Compressor (Soft Bags)'.**

Find the compressor, as shown here. We need to remove the top, as it won't be needed until the very end! We do this by removing the three nylon nuts on the top of the plate. These are only hand tight and they will be reinstalled without any tools as well.

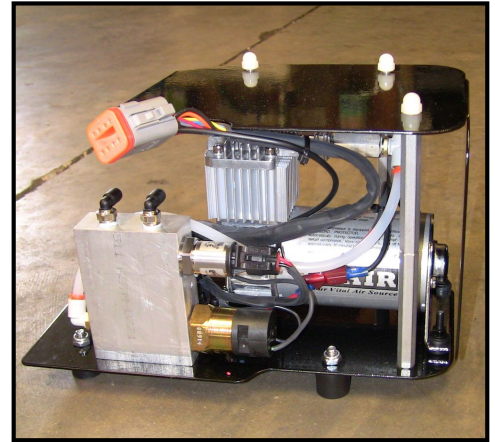

Once the top is off the compressor should look something like the picture below. We want to slowly install the compressor in the bag. The silver valve system goes toward the back, and the compressor is slid back as far as it can go. It is mounted on rubber feet to avoid damage to the bag, and to reduce vibration. The picture here shows the compressor plugged in, with lines attached.

**NOTE: We supply you with some black rubber edging. It may be used if after installing the compressor you find the metal edge touches the hard bag somewhere causing a vibration. If once the compressor is on, you need to, cut pieces of the rubber and slide it on the metal where needed to keep the vibration down.**

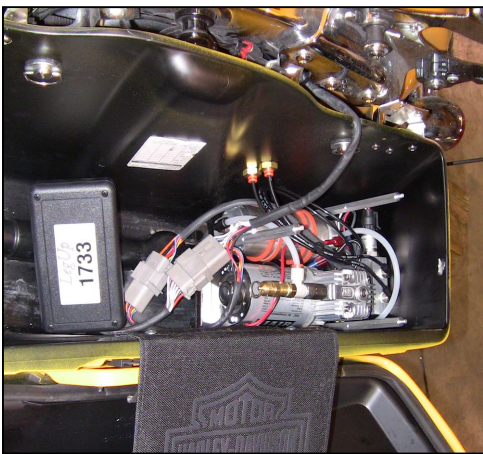

Once the compressor is in place, the air lines should be attached to the fittings you mounted in the saddlebag.

The compressor should feel very stable in its new home. Assuming it does, this would be a good time to run the big wire into the bag, and connect the computer (seen left with the label on it) to the 12 pin plug, and connect the compressor to the 8 pin plug.

These plugs can only be attached one way, and we are going to leave the computer and wires just loose in the bag for now.

I promise we will make it all pretty before you are done.

In preparation for testing the system, if you haven't already, hook the negative battery terminal and the lead from our power connection, up to the negative battery terminal (don't worry that the proximity sensor is still lying on the lift!).

Skip the next section on 'Soft Bags' and jump to 'Initial System Testing'!

# INSTALL THE COMPRESSOR (SOFT BAGS)

**NOTE:** *If you have hard bags (all but Road King Customs & Classics), skip to the next section; 'Initial System Test'.*

Now we need to install the compressor into the bag. The fit is tight and the bag is flexible, so take your time here.

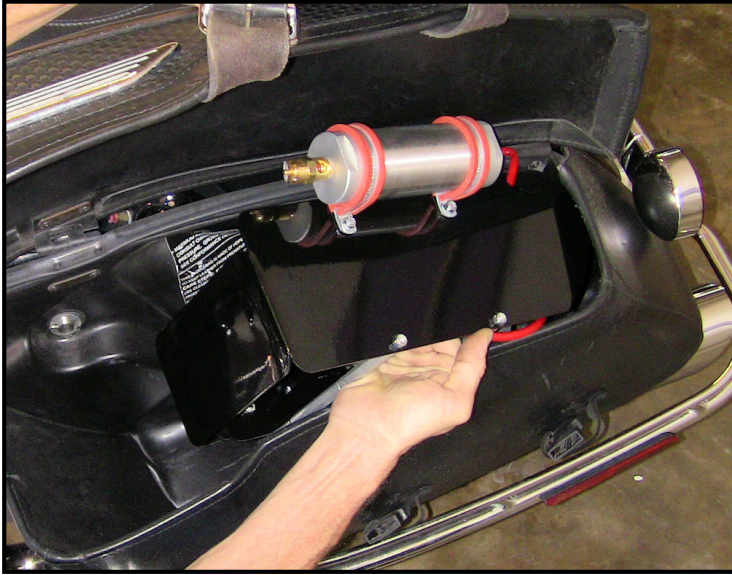

The picture at left shows us starting the compressor into the bag. As we do this, we take the two air lines with male-male fittings attached and start it through the hole you drilled into the bag.

When we install the wire harness, you will need to tilt the compressor forward to reach the plug under the top!

Once the compressor is nestled into the bag, it should look like the picture below. Make sure the system is pushed all the way to the back of the bag, and feels sturdy in its new home.

Next we will install the bag, and attach the lines.

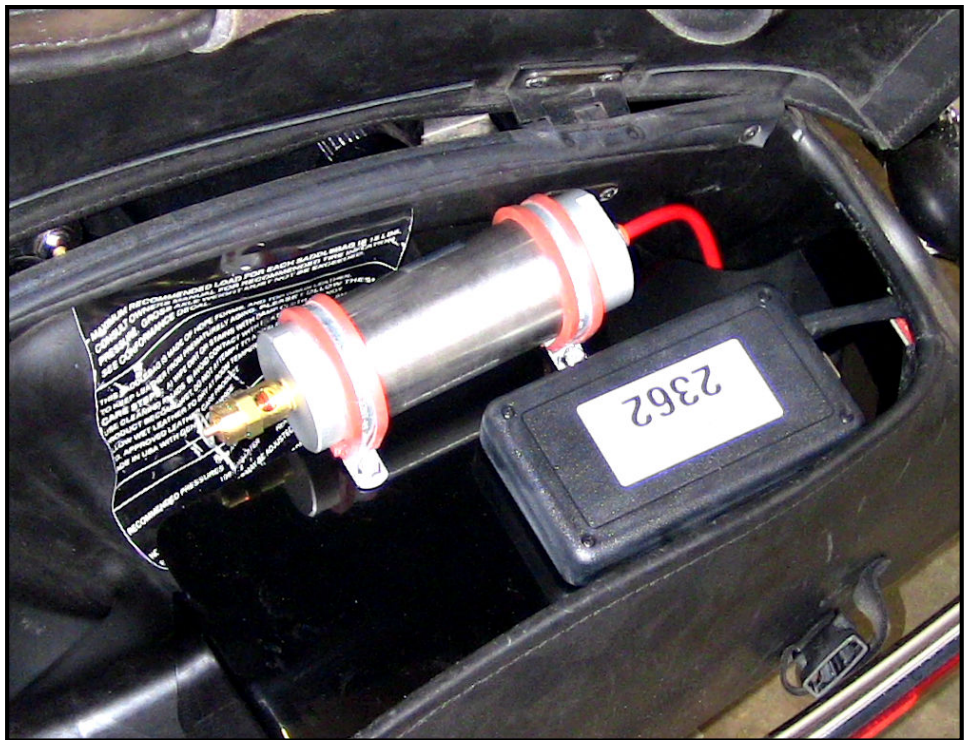





We need to find the inline connectors (white in this picture, could be a different color) and attach them to the end of the lines you ran toward the back of the saddlebag.

Next, put the bag on the support rail, tilted out toward you as shown here. Attach the two small lines to the connectors from above. Give a tug to make sure they are snug. At this point, it is helpful to push the extra small line back into the bag. Again, make sure the connections are tight!

Now attach the bag to the bike. ***NOTE: Once the system is operational, in order to remove the bag, you will make sure the wheels are up, pull the ring on the safety valve of the tank to let the air out, tilt the compressor forward to disconnect the plugs, and remove the rear bail nut, then disconnect the hoses at the white connectors and remove the bag!***

Run the wire with the two plugs into the bag all the way toward the back; just behind the end of the rubber gasket. Find the computer and plug it into the big plug, then plug the small plug into the plug from the compressor (you will likely need to tilt the compressor forward to get to the plug under the cover), guide the wires neatly so as seen at left.



In preparation for testing the system, if you haven't already, hook the negative battery terminal and the lead from our power connection, up to the negative battery terminal. On to Initial Testing (don't worry that the proximity sensor is still lying on the lift!).

# INITIAL SYSTEM TEST

Turn your bike to Accessory Mode (counter clockwise on Road Kings, all the way right on other models). Your speedometer should illuminate, and if everything is working properly, the compressor should turn on for about 6 seconds to fill the onboard air tank. At this point, have a look at the yellow proximity sensor.

***PLEASE NOTE: Immediately after turning on your bike (within 5 seconds), the top light on the handlebar control will flash for a few seconds. This is the system either making sure that no air is in the legs if they are up (for safety it makes sure air does not build up when the legs are in the up position), or that the proper amount of air is in the system if they are down (again for safety to make sure the legs stay pumped completely!). This test occurs once a minute for all the time the bike is powered up, whether you turn the LegUp system on or not!***

The **RED LED** (ON The Sensor) ***Should Not Be Lit***. Take a metal object (screwdriver, wrench, etc.) and hold it on the flat face of the sensor (it has a circle embossed in it). The LED should light up, and go out when you move the metal away. If not, check all your connections.



Next, press the rightmost pushbutton on the handlebar switchbox, and hold it for at least 3 seconds. Both LEDs on the switch panel should light up; green means the legs are up and yellow means the bike is traveling under 6MPH. If this occurs, you are doing well.

The next step requires some care. If the bike is still on the lift, have a helper hang on to it as you touch the left button for just a split second. The legs should move down, likely until the wheels hit or miss the lift, and they do this **VERY** quickly! The compressor will likely start and run for about 10 seconds. Press the left button again and they should move up.

If all of the above has occurred, great! Turn the ignition switch off, the test is complete!

Let's move on to mounting the Proximity Sensor.

# MOUNT PROXIMITY SWITCH

**This step is crucial!!** Understand it before starting. The proximity sensor tells the system how fast the bike is traveling. The proximity sensor mounts to the swing-arm at the rear pulley. Depending on the year of the bike, it will mount 5MM from the pulley bolts or we will be attaching metal squares to the face of the pulley. No matter what type of pulley is on your bike, you need to jack up the rear wheel so we can spin it to test the sensor and its placement. Make sure the bike is in neutral.

## BIKES WITH PULLEY BOLTS

With the bike up as described above, turn the ignition switch to the accessory position. The LED on the sensor should be out. Place the mounting bracket on the swing-arm and line it up up to where the main part of the sensor is aiming at a pulley bolt and is centered on it (you may have to turn the wheel to do this). What we are looking for is for the LED to go bright and OFF as a pulley bolt passes the sensor. Play with this by rotating the wheel back and forth while holding the bracket in place. Once you feel you have the right place, hold the bracket steady and slowly rotate the wheel. Every time a bolt passes, the light should get bright when the bolt is nearby and off after it passes.



If this is not happening, you may need to get the sensor a bit closer to the bolts (5MM is a very small distance!). If you have to move the sensor closer, you may have to shim the back of the bracket. No matter what you need to do, you **MUST** make sure that as the wheel turns, the light works as described above! Once you are certain, attach the bracket permanently with the 2 sided tapes and test it again! If all is perfect, you may optionally fasten this more permanently by drilling a hole in the swing-arm and attaching a sheet metal screw to keep it in place if you choose (mine is not screwed on and has held in place for years!). The automatic retraction of the legs as well as their deployment **RELIES** on this sensor being placed perfectly!

Once satisfied with the mount, skip down to the wire routing instructions below.

## BIKE WITH NO PULLEY BOLTS (CUSH-DRIVE)

With the bike on the lift, the rear wheel off the lift and the bike in Neutral, remove the bottom bolt from the right shock at the rear of the bike. Insert the top of the bracket shown at left, behind the shock and in front of the hole in the swing-arm, so the bolt will pass through it when reinserted.

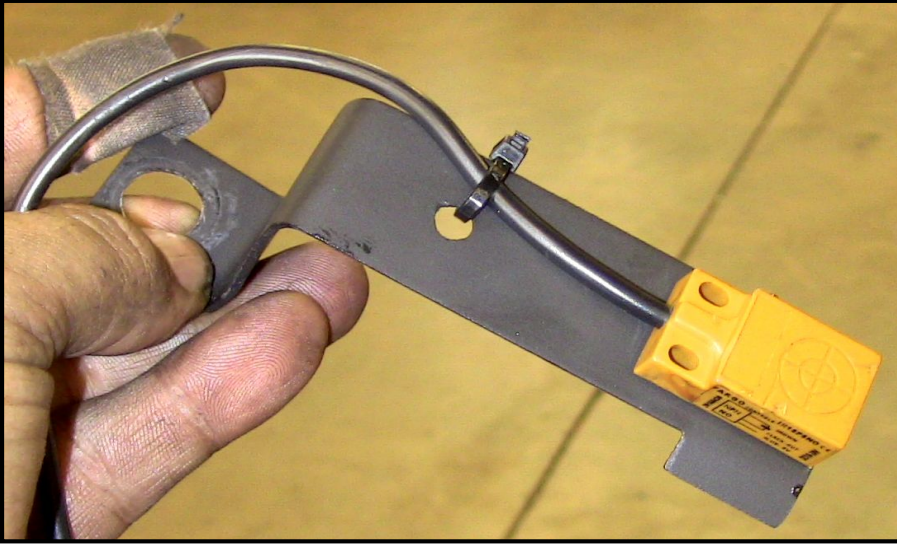

**NOTE:** the yellow sensor seen here will be close to the brake rotor and below the shock bolt (see below).

Reinsert the shock bolt and tighten the nut, while holding the bracket forward against the swingarm as seen here.

Get the shock bolt snug!

We next have to set the sensor so it finds the spokes of the brake rotor (not the bolts as in the past!) at a distance of 5MM (about 1/4").

Be prepared to bend the bracket to get to the sensor in the correct position.

When you think you have it, turn the ignition to Accessory position, and roll the wheel to make the spokes of the rotor pass by the sensor. Each time one passes the sensor, the LED on the sensor should go bright then off.

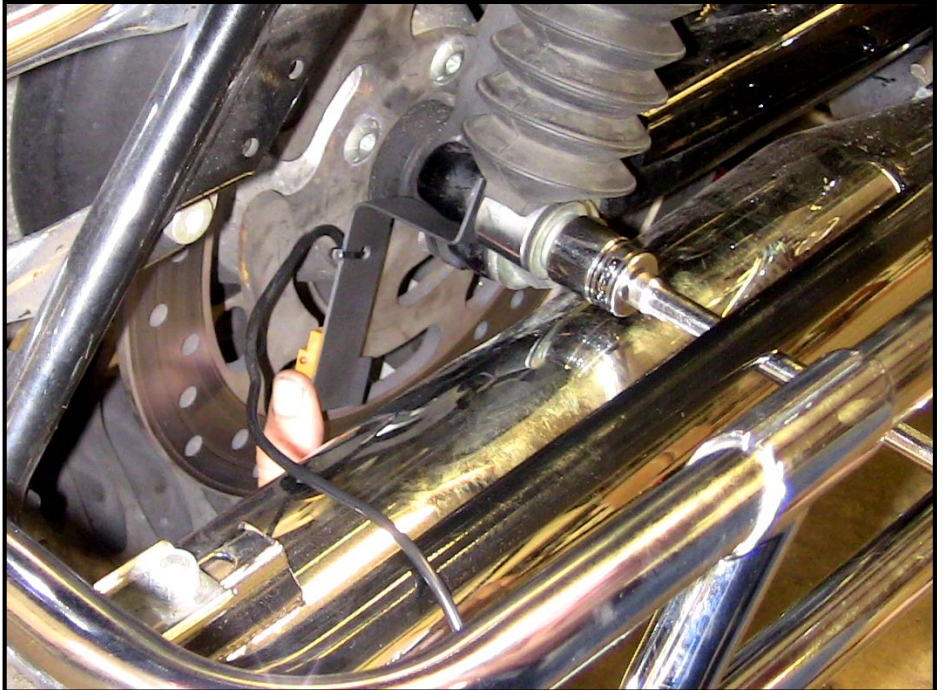



If this is not happening, you may need to get the sensor a bit closer to the brake rotor (5MM is a very small distance!). If this is not happening, you may need to get the sensor a bit closer to the brake rotor (5MM is a very small distance!). If you have to move the sensor closer, you may have to bend the bracket just a tad (you may even need to loosen or remove it to bend it as you need to). No matter what you

need to do, you **MUST** make sure that as the wheel turns, the light works as described above! Once you are certain, tighten the shock bolt and test it again! Rotate the wheel past all 5 spokes on the brake rotor and make sure the light blinks and goes out each time. If all is perfect, you are done! The automatic retraction of the legs as well as their deployment RELIES on this sensor being placed perfectly! Now we can route the wire.

# WIRE ROUTING

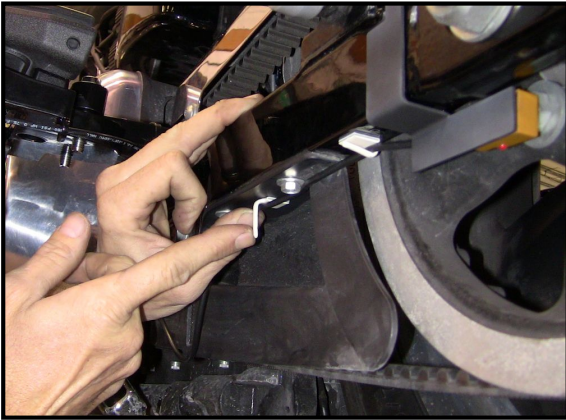

Tie the Proximity sensor wire down the left side of the swing arm for pulley bolt bikes, or the right for Cush drive bikes. Use the supplied self-adhesive tabs, to secure the wire snugly to the swing arm. Just make sure you route this safely and tie it off securely! Finally pull all the extra wire under the seat area.

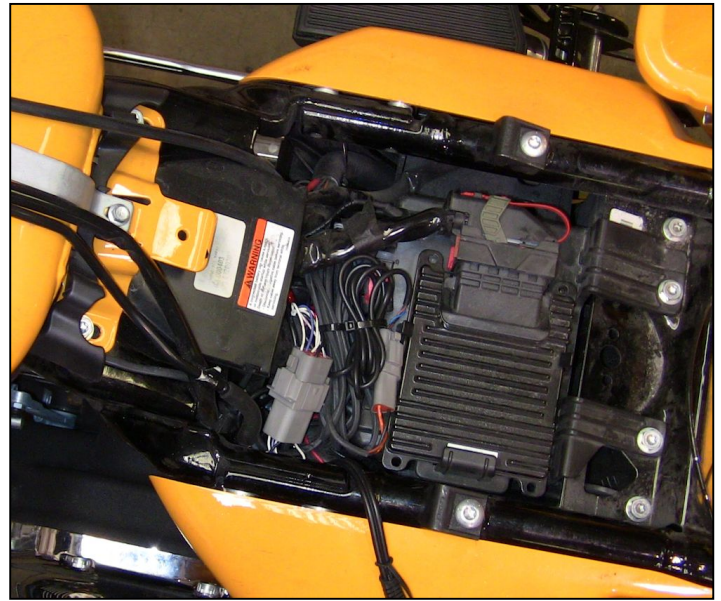

Your wire from the handlebar should already be under the seat, tied off to the handlebar neatly from the switch to the triple tree, and secured safely under the tank. Now is a good time to tie up all the wires under the seat. First make sure you have all excess slack pulled under the seat. We loop our wires, tie the excess as a bundle, make sure they don't interfere with the seat, and tuck them in as shown here.

We need to make sure the compressor plug is attached and tucked in as we install the top. Find the L-shaped metal top that you removed from the compressor earlier. The top mounts with the two holes toward the back of the bag, with the single hole toward the front. It is a tight fit, so slanting it into the bag is best.

As you work the top over the 3 aluminum standoffs, make sure the computer and plug (sometimes it is easier to unplug the computer until the top is set) are coming through the curved cutout (Hard Bags only) , as the plug and computer will sit on top of the compressor system. Once the top is fitted, find the 3 nylon nuts and screw them on the three posts to secure the cover. These are plastic nuts so no wrench is required here.

When complete, you want to Velcro the computer onto the top and make sure the plug (*the compressor plug stays UNDER the top*) and wires look something like this. The top picture shows a hard bag, while the bottom shows a soft bag. Our main concern here is to give you as much of the saddlebag as possible, and make sure the wires and components are not going to be chaffed or damaged.

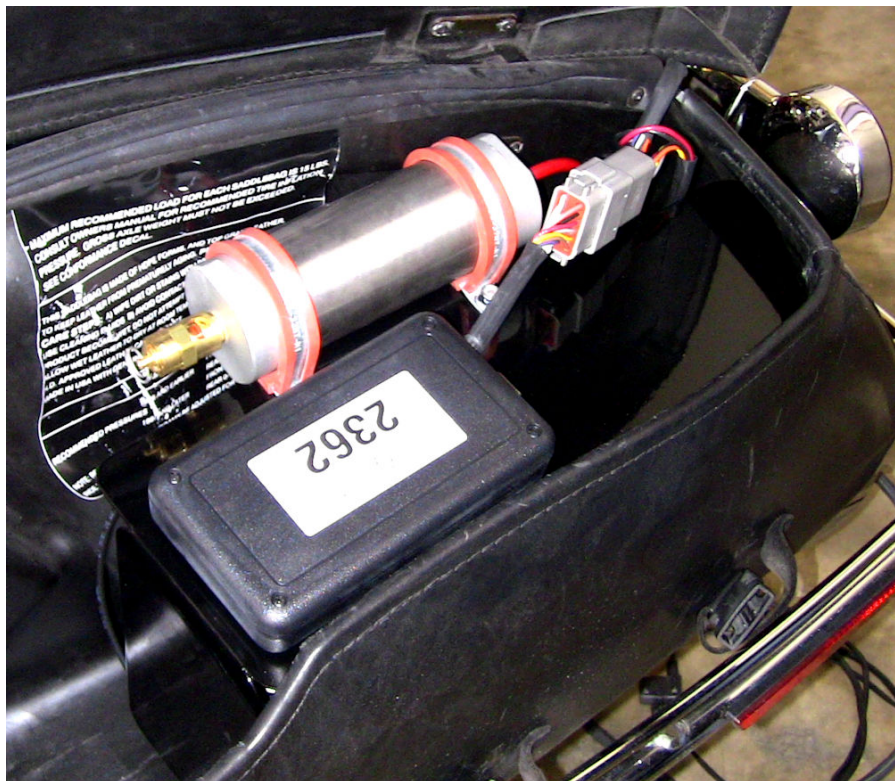
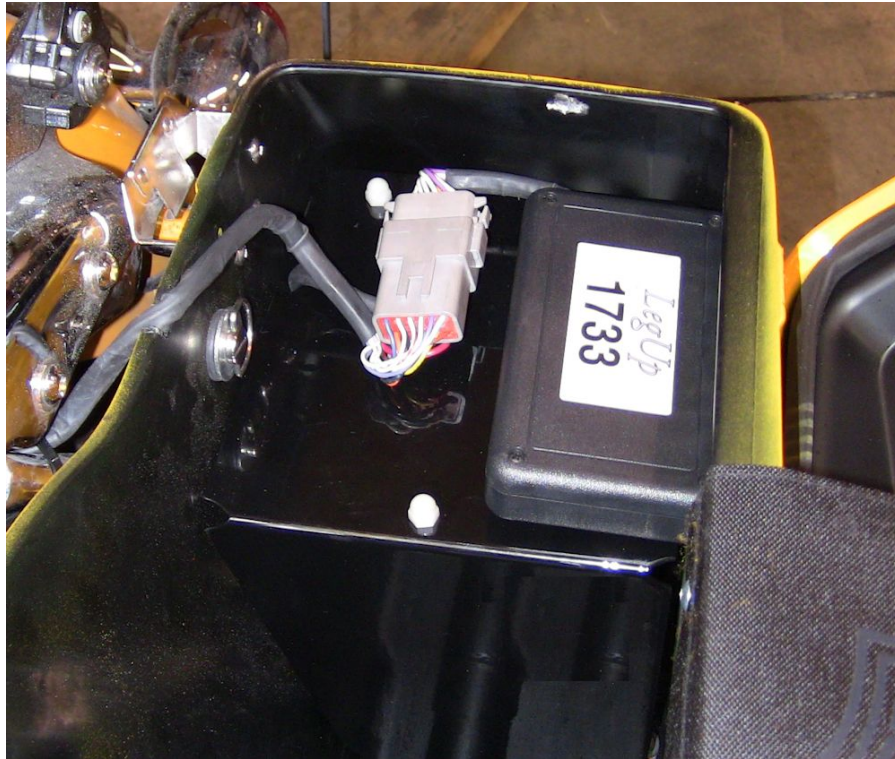

# FINISHING UP

Now it is time to reinstall everything you took off, and do final checking of everything! Reinstall the seat making sure all your wires are routed neatly, tied off nicely and don't interfere with the seat installation.

Once all of this is accomplished, we should get the bike on the ground, and with a helper, cycle the wheels up and down a few times, having your helper make sure the air lines are not being scuffed or are over tight, and that the wires are out of the way of anything that could damage them.

Double-check all your bolts for tightness. Now we can dial in the legs, and adjust the wheels if needed.

## LEAKS!

This system uses air, and air loves to leak! The fittings we use are tested for leaks before shipping, but we have a few simple tests to make sure you have no leaks or just insignificant ones if any.

Set the wheels down and leave the system on. Put the kickstand down, and turn the bars all the way left.

If the compressor makes noise more than once every two minutes, you may have a leak at the lines that connect to the compressor or the tank fittings. Some soapy water will tell you where (you will need to remove the compressor top to test for these leaks).

Assuming the compressor doesn't lose enough air to kick on after 2 minutes, you should be fine.

You can turn the bike off, and wait to see if in 5 minutes the bike is not as stable as it was when the wheels were first lowered. If it lasts the 5 minutes and is still very stable, you could still have a leak, but not one that would be a problem on the road!

Leave the bike on its wheels overnight (again kickstand down, bars full left in case the legs lose a lot of air; the bike will land on its stand). If in the morning, the bike is still stable you have no leaks.

If there are leaks, the fittings on the air cylinders would be the first for the soapy water check, with the two small line fittings on the compressor next! If you need help with these, please feel free to call us at (407) 834-5007.



## FINAL ADJUSTMENTS & MAINTENANCE MODE

The next two sections are typically **NOT** needed. We include them to document your system thoroughly, but **MOST** people will never need to use either section.

### MAINTENANCE MODE

***NOTE: Maintenance mode is a procedure that ‘TEACHES’ the computer how much pressure to use when it lowers the wheels and how much pressure to release when raising the wheels. We always set this at the factory; ALWAYS!! We include this procedure in case it is ever needed in the future. Please skip this section unless you have been instructed to reset the system by Chopper Design.***

Turn the ignition to Accessory and start the LegUp System (hold right button for 3 seconds). The system should be set at the factory for proper pressure, but some wheel adjustment may be needed. If it has been determined that ‘**Maintenance Mode**’ is needed, Sit on the bike, and hold it level. If both lights on the switch box are flashing, the system is in maintenance mode. If not, **PRESS & HOLD** both buttons until all lights flash. ***(Do your best to press both buttons at the same time so the system doesn’t respond to what it thinks is a request to lower the legs)*** Once flashing, hit both buttons for an instant to get the system in the ‘**DOWN**’ setting mode (lower, yellow LED flashing). Touch the left button briefly; the wheels should go down immediately. ***(This is VERY quick, don’t be startled!)*** Using very short pushes of the left button, press and then feel the stability of the bike. If it feels firm enough, try leaning the bike a bit. If the wheels return the bike to upright, there is likely enough pressure. Put your feet on the floorboards; the bike should stand on its’ own. Rock the bike a bit left and right, being prepared to put your feet down. If the bike continues to come back to upright, the **DOWN** stop is now set and we can move on.

Hit both buttons for a moment to get into the ‘**UP**’ stop mode (Usually hitting the left button just before the right assures that air is not released!) The top LED should now be blinking. Press and hold the right button to raise the legs. Listen as the air evacuates; once it is quiet, let go of the right button. The **UP** stop is now set! Hit both buttons when complete, Both LEDs should light, and you are done with these adjustment.

Now press the left button and the legs should lower; again this is fast and loud. The bike should be held up firmly! Hit it again and the legs should retract. If you are satisfied with these limits, you have successfully installed the LegUp System.

## WHEEL ADJUSTMENT

*The LegUp GEN II system is typically set up at the factory for the height of your bike. The system is **VERY** height dependent! If after testing the initial installation, the bike does **NOT** feel stable, the wheel system **MAY** need to be adjusted to the height of your bike. **AGAIN**, we normally ask at order time if your bike is at stock height and we set the system up for whatever height you have furnished us. **DO NOT** make any changes unless the stability we expect is **NOT** present! If you feel you need to adjust the height/length of the wheel holders, please read this **ENTIRE** section before starting the process. If you need help, please contact Chopper Design at 407-834-5007.*

If you are happy with how stable the bike feels, you can skip this section, and move on to a test ride! If you are not sure, or you skipped **'maintenance mode'** as instructed, a good test is to bring the wheels down, put the kickstand down, and lean (or try to) the bike on its kickstand while sitting on the bike. If the bike comes back to center without your help, or you put your feet on the boards and can bring the bike up by just leaning to the right; move on to the next section (Test Ride), the wheel settings are fine!

The stability of the GEN II LegUp system, relies on the pneumatic actuator, when deployed, being at an angle that is forward of perpendicular for best results! Different bikes are at different heights, and Chopper Design uses an ingenious method to adjust the length of the supporting legs to maximize the stability it affords.

Typically, we will send the 'Leg Assemblies' set up for the bike you told us you had. We have three different 'Standard' setups for the Harley Touring bikes.

Standard FL Height, Street Glide and other bikes using the Harley lowered shocks, and the new 'Ultra Low' models.



The first picture (above) shows the setup for standard height Harleys. The boards are set in the highest position, the wheel holder is set with the strap facing up and the small bolts set in the second and fourth hole from the back of the leg (Notice curve of wheel holder). This is how we should have sent the legs to you if you told us you bike was at stock height!

At left, we see a setup for a Street Glide or other bikes with the Harley Lowered shocks. The small bolts are again set in the 2<sup>nd</sup> and 4<sup>th</sup> holes from the back, and the strap that holds the wheel holders together is on the bottom of the leg. You can tell because

the curve of the wheel holder is the opposite of the first picture. The floorboards should be set at their highest position as well, for these bikes.

This last picture (below) shows the setup for the new 'Ultra Low'. This bike does not come with rear floorboards, much like the 'Street Glide', so Harley or aftermarket boards **MUST** be installed!

In order for the 'LOW' to work as well as other bikes, we have to use our adjustable wheel holders. It may be hard to see here, but we move the wheel axle up to a second hole (1), and the big axle at the top is set at the lower hole (2). These two changes make the legs shorter to offset the low height of the bike.

The floorboard needs to be in the highest hole. The bolts that orient the wheel holder need to be in the third and fifth hole from the back.

They also need to be threaded through the hole that is second from the back on the wheel holder (3). If you told us you have an 'Ultra Low' this is how we would configure the system before shipping. We just furnish this info to document the setup.

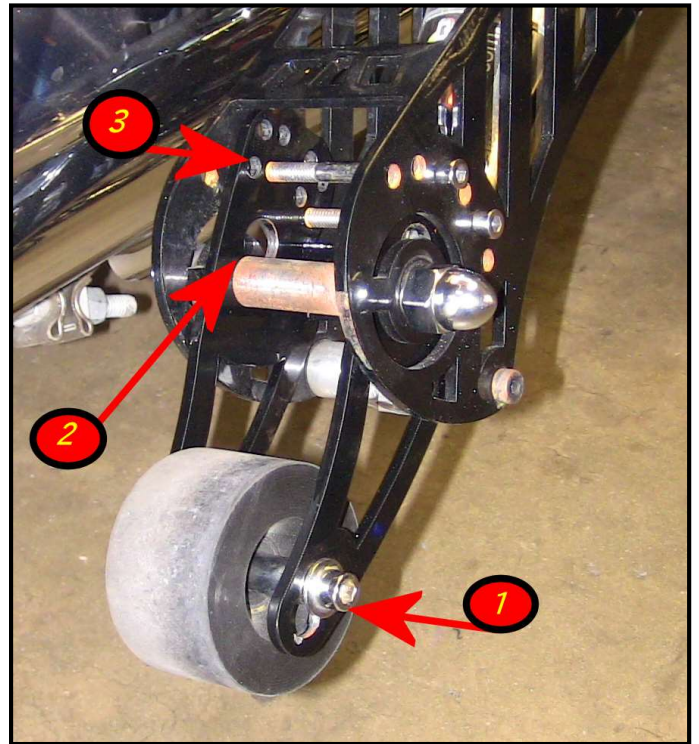

***IF YOUR BIKE FITS ONE OF THE THREE SCENARIOS WE HAVE DISCUSSED ABOVE, IGNORE THE NEXT SECTION! WE DO EVERYTHING WE CAN TO SET THE SYSTEM UP BEFORE SHIPPING. IF YOU ARE NOT SURE, PLEASE CONTACT US BEFORE ADJUSTING THE SETTINGS OUTLINED BELOW! IF YOU HAVE A REMOVEABLE LOWERING KIT INSTALLED, YOU MAY WISH TO CONSIDER REMOVING IT AS THE NEED SHOULD BE REDUCED SIGNIFICANTLY BY THE LEGUP SYSTEM.***

We now have designed wheel holders that allow **SIGNIFICANT** adjustment to make the LegUp system match the height of your bike perfectly. The adjustments can take time to get perfect, so be patient and understand this section before adjusting anything. We try to get enough information from you before shipping our systems so we can setup the product for you, before it is shipped. Also, if you do the measurements we show you below, you can contact us, and we can likely tell you how to change the setup to match your bike.



Before we start, make sure the floorboards are set to their highest position!

Ideally, we want the bottom of the board mount at a height of between 13" & 14.25".

Measure this from the small donut on the bottom of the board mount in the center of the board with the bike held level (we set the bike on a jack here, but you can have someone try to hold it upright if need be). We suggest taking this measurement from both sides and dividing them in half. Armed with this info, we can use the list below to find a good starting point to set the wheels up properly!

- **FLH = 14 1/4", One from Back, Strap Up**
- **FLHX = 13 3/4", Two from Back, Strap Down**
- **Low Bike = 13 1/16", One from Back, Strap Down, Wheel On High Hole**

Strap Up or down, refers to the strap that holds the wheel holders together. One or Two from back refers to the bolts that are used to lock the wheel holders into position as it is pivoted around the big axle. Wheel on High Hole or Low Hole (Default) refers to where the wheels are mounted on the wheel holder. We also have two holes at the top of the wheel holder that can be used for a bike that is VERY low!

On the next page, we show you the wheel holders which should help clear up any confusion you may have about the wheel holders and their adjustments.



On each supporting leg, you will find two bolts down near the end by the wheels. The two bolts control the angle of the ‘Wheel Holders’. By moving the wheel forward or back, we can tailor the length of the support arms to a particular bike.

A helper is handy here. Make sure the wheels are up. Make note of exactly which two holes the bolts are in. Loosen the locking nuts from the back and remove the bolts; you will notice the ‘Wheel Holder’ can pivot on the big axle bolt. Starting on

the left side of the bike, move the bolts one hole counter-clockwise. Go to the right side and move them one hole clockwise. Loosely fit the nuts (no need to final tighten them at this point).

Lower the legs. Is the bike more or less stable? If it is more stable, and you can sit on the bike and rock it back and forth without it leaning over you are done. If not, remove the bolts again, and move them in the opposite direction two holes, and retest. If everything is fine, final tighten the lock nuts and you are done.

If you need to, you can move the wheels from the lowest hole, up one hole. You can remove the wheel holders, turn them over (strap up instead of down for example) and install them on the other side of the bike. You can move the big axle from the low to the high hole. All these techniques take patience, but allow significant flexibility to tailor the system to your bike. On the next page we show you some examples. Normally you do not need to do **ANY** of these adjustments, but if you need to, we wanted to teach you the methods at your disposal.

The picture below left, shows the wheel holders set up for touring bikes with full length shocks (Electra Glides etc.) The one at right is set up for lowered bikes (Street Glide and others). Notice how the curve of the left one is toward the front of the leg, and the curve on the right one is toward the back? This small change can make a big difference in how stable the bike may be. If you are having trouble getting the stability you need, you can remove the 2 small and the one large bolt that connects the wheel holders to the legs, and swap them from one side of the bike to the other. This will reverse the direction of the wheel holders and keep the wheels aligned properly.

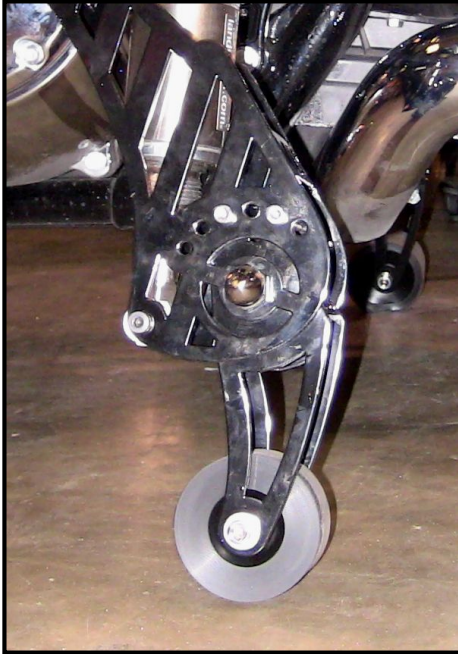

Again, this is only needed if you are not getting the stability we describe above.

Below is a picture that shows the angle of the actuator when the wheels are set properly. Notice the bottom of the cylinder (silver, inside the black legs) is further forward than the top! Yours should look like something like this. Also notice that the floorboard is level. We have seen one bike that had floorboards that leaned forward, which would **RUIN** the geometry required here. Please verify that your floorboards are level!



If you are still not getting the stability we describe here, please call us, and we will try to determine why not (407-834-5007).

# TEST RIDE

***PLEASE NOTE: Immediately after turning on your bike (within 5 seconds), the top light on the handlebar control will flash for a few seconds. This is the system either making sure that no air is in the legs if they are up (for safety it makes sure air does not build up when the legs are in the up position), or that the proper amount of air is in the system if they are down (again for safety to make sure the legs stay pumped completely!). This test occurs once a minute for all the time the bike is powered up, whether you turn the LegUp system on or not!***

The first test should be done in a straight line. Put the bike in gear and slowly accelerate. You may notice that the bike tends to want to steer a small amount left or right. This is normal unless it is severe. Effectively, you are driving a trike, and steering is done with the handlebars **NOT** by leaning. Once underway, (we recommend you keep your thumb near the left button, and press it to raise the wheels if there are any surprises) the top LED should flash at around 6 MPH, meaning the legs are retracting. It is difficult to lean on one wheel or the other as you leave, so you may wish to raise the wheels manually if the bike is steering due to uneven pavement.

Assuming the legs are retracted, you should try to deploy the wheels. As you come to a stop, the Green LED should be on. As you slow down (**almost stopped**), the Yellow LED should illuminate at the proper speed. Once it does (sometimes hard to see), hit the left button and put your feet down near the ground. The top LED should flash and the wheels should deploy almost instantly underneath you! Make sure you are ready to balance the bike, though you likely won't have to! Immediately after the wheels touch the ground, the bike should be supported reasonably, but the cylinders can take up to 6 seconds to get completely filled. Make sure you balance the bike as this occurs. The slower you are going when deploying the wheels, the smoother the transition will be from wheels up to wheels down. Practice these maneuvers until you are comfortable with the wheel adjustments and the system operation.

***NOTE: With the system on or off, if the legs are up, the computer will dump the air from legs once every minute that the bike is turned on! This is a safety feature to make sure pressure does not build inside the legs, causing them to deploy! The top light will flash once a minute for a few seconds. This is completely normal, and the left button will be inoperable while this occurs.***

***SEMI-AUTOMATIC DEPLOYMENT:*** Another way to deploy the legs is semi-automatically. First we must be **SURE** that the proximity sensor is working properly or the wheels could come down at higher speeds than we wish. If you are travelling at a speed over 10 MPH, AND the yellow light (bottom) on the handlebar control is out, hit the left button. The bottom or yellow LED should start to flash. When you slow down to around 5MPH the wheels will deploy (see the red/green flash on top LED). Again prepare to put your feet down. IF the lower LED is lit at a speed over 10 MPH, don't hit that button; see caution below!

***NOTE: The bottom LED Should not be LIT SOLID if the bike is travelling over 10MPH! In the event it is, the wheels will deploy instantly if you try to set them as above; this is dangerous! You MUST re-visit the sections on testing the proximity sensor. You should always be aware that this light should NOT be on if you are traveling at speed, and 'Arming' the system for deployment should only be attempted if the lower LED is Not Lit! Please see the User Manual for more information on Proximity Sensor Failure!***

The next thing to try is to make a turn from a dead stop with the wheels down. As soon as you start the bike moving, turns can only be made by using the handlebars. The LegUp system is too strong to allow a great deal of lean with the wheels down! If you need to make a turn shortly after departing from a stop, raise the wheels manually (left button) and you will get complete control again.

The next thing to try is slow speed maneuvering with the wheels lowered. If you keep your speed down, most slow speed maneuvers can be accomplished with your feet up, keeping in mind that at about 6 MPH the wheels will come up automatically! You can try full lock turns in both directions and the bike should stay upright with your feet up.

Understand; it is always a good idea to keep your feet near the ground during these maneuvers if you can. A mechanical failure or a wheel in a pothole could upset the bike.

Because the wheels are right behind your legs when they are down, we recommend not trying to push with your feet to move the bike forward. Use the engine and keep your feet out of the way; this way the legs don't bite at your heels as the floorboard always have! Backing up using your feet works fine and the chore of balancing the bike is taken care of for you.

Practice, practice, practice!! Enjoy your LegUp System!



# GENERATION I UPGRADE INSTRUCTIONS

***NOTE: Read this before starting your installation if this is an upgrade!***

If you are upgrading from a Generation 1 system, most all the instructions in this manual pertain to you, but some do not! The most important thing is to **NOT** take your wiring harness off the bike! We should have supplied you with an upgrade harness that will allow you to keep most everything as it was, and adapt the wiring to the new system. The second **VERY** important thing is that your computer **MUST** be sent in for upgrading or it will not work with the new Generation II system! With those facts in hand, let's get to it!

We will assume you have already removed all your Gen I hardware. The legs, the actuator mounts, the mounting plate. All you should have left from the old system is the wiring harness.

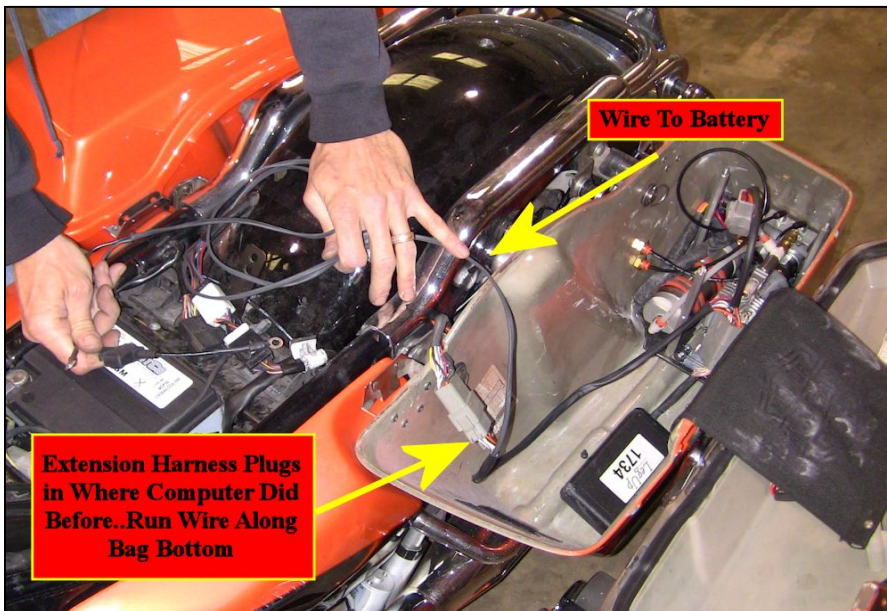

The upgrade harness plugs into where the old computer plugged in. This is a 12 pin plug on the opposite end of the upgrade harness from the two plugs that are close together.

Once this is plugged in, we like to run the wire with the two plugs along the bottom of the bag, back to the compressor.

The thin wire with the fuse holder on it gets run back toward the seat

area to get connected to the battery. You can tie this up to the existing harness wires along the route back to the battery.

These are only suggestions; run the wires anyway you like; your existing connections to power will remain as they are. One caveat is that the plug that used to run to the actuator will have no plug in it. This should not be a problem assuming it is stored in an area that does not get very wet.

When reading the install manual, you should be able to ignore most all instructions having to do with wiring and you will **NOT** need to do the proximity test by rolling the bike, as this should remain mounted.

If you have any trouble with this upgrade, please give us a call at 407-834-5007.

# ILLUSTRATIONS

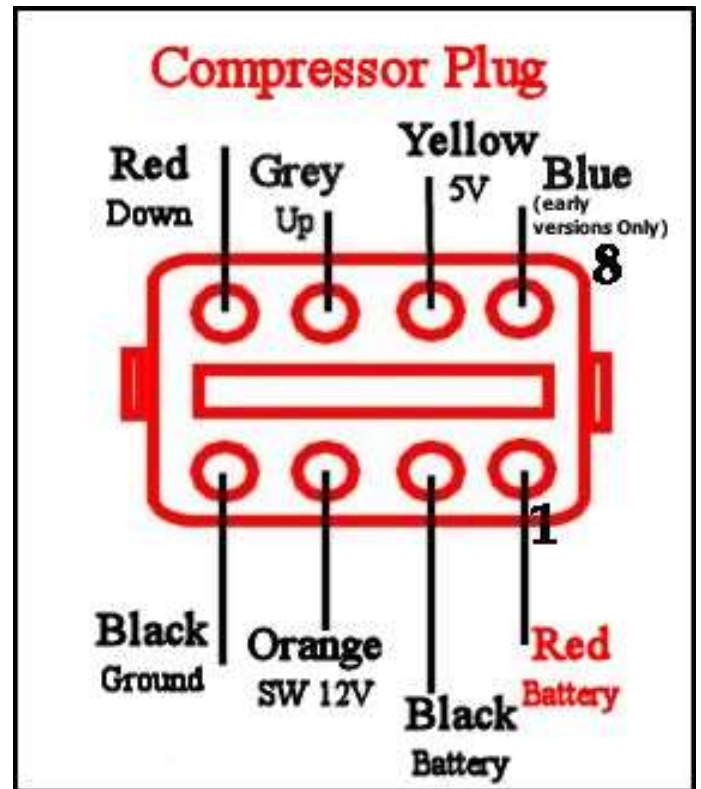
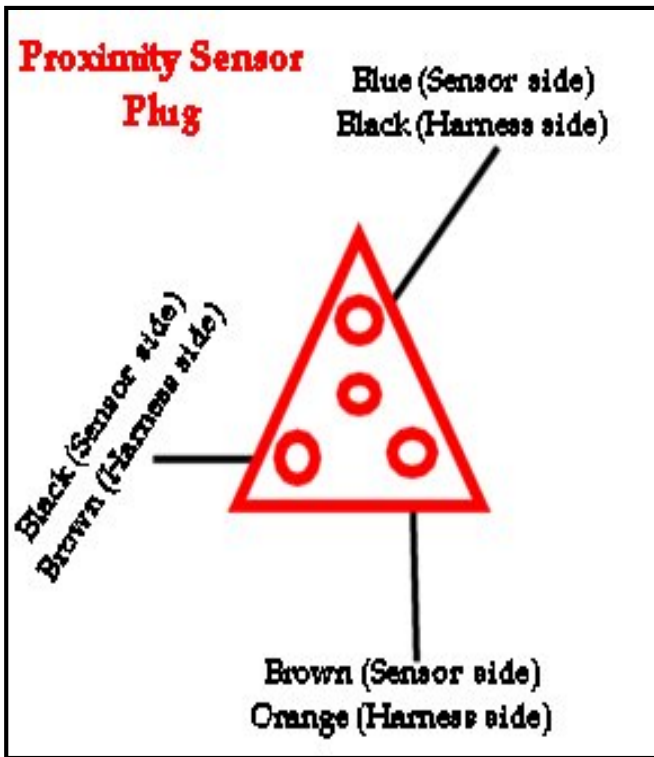

*Due to global distributions problems, we may have to use a four pin plug instead of a 3 pin plug. The colors still need to be the same across the plugs with pin 4 empty!*

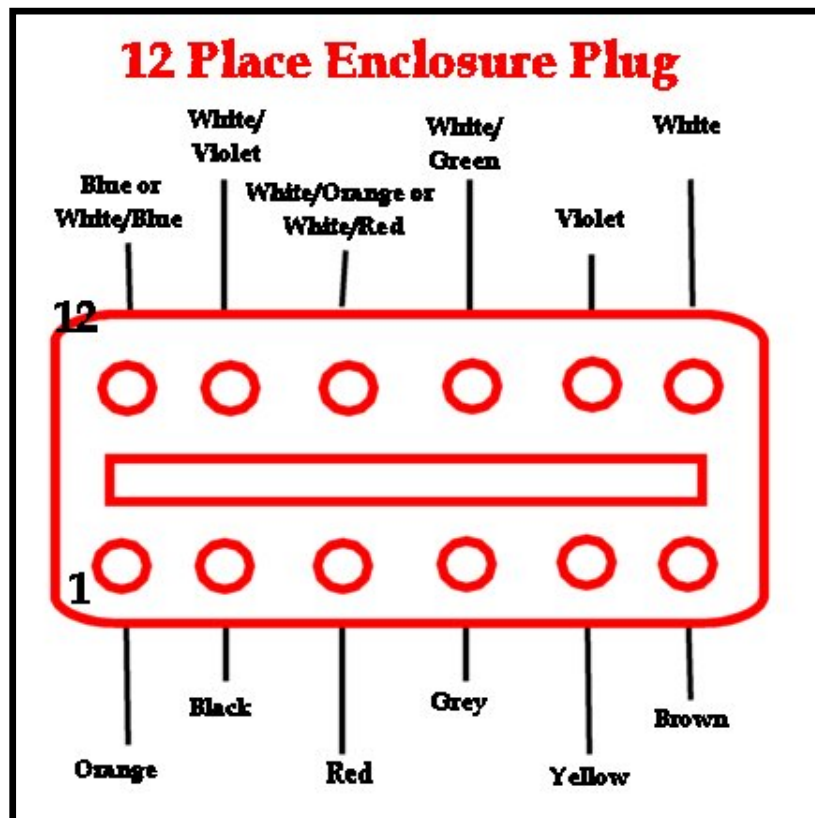

# SADDLEBAG DRILL TEMPLATE (HARD BAGS)

**Print and Cut out Make Sure Dimension is Correct!**

**Some printers don't print to scale!!**

**(Cut Out and Flip for Right Side, CVO Bags)**

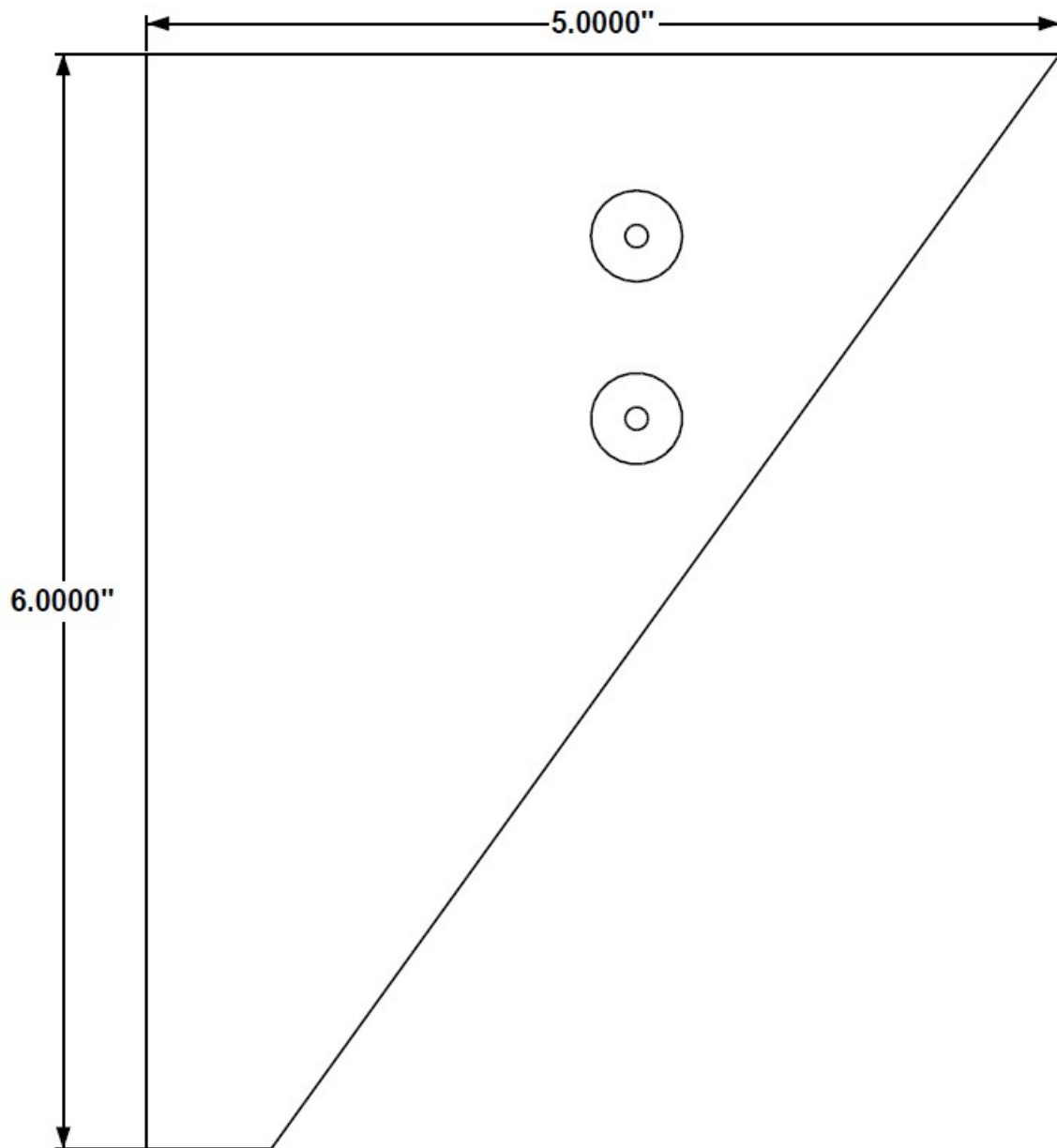

# SADDLEBAG DRILL TEMPLATE (SOFT BAGS)

**Print and Cut out Make Sure Dimension is Correct!**  
**Some printers don't print to scale!!**

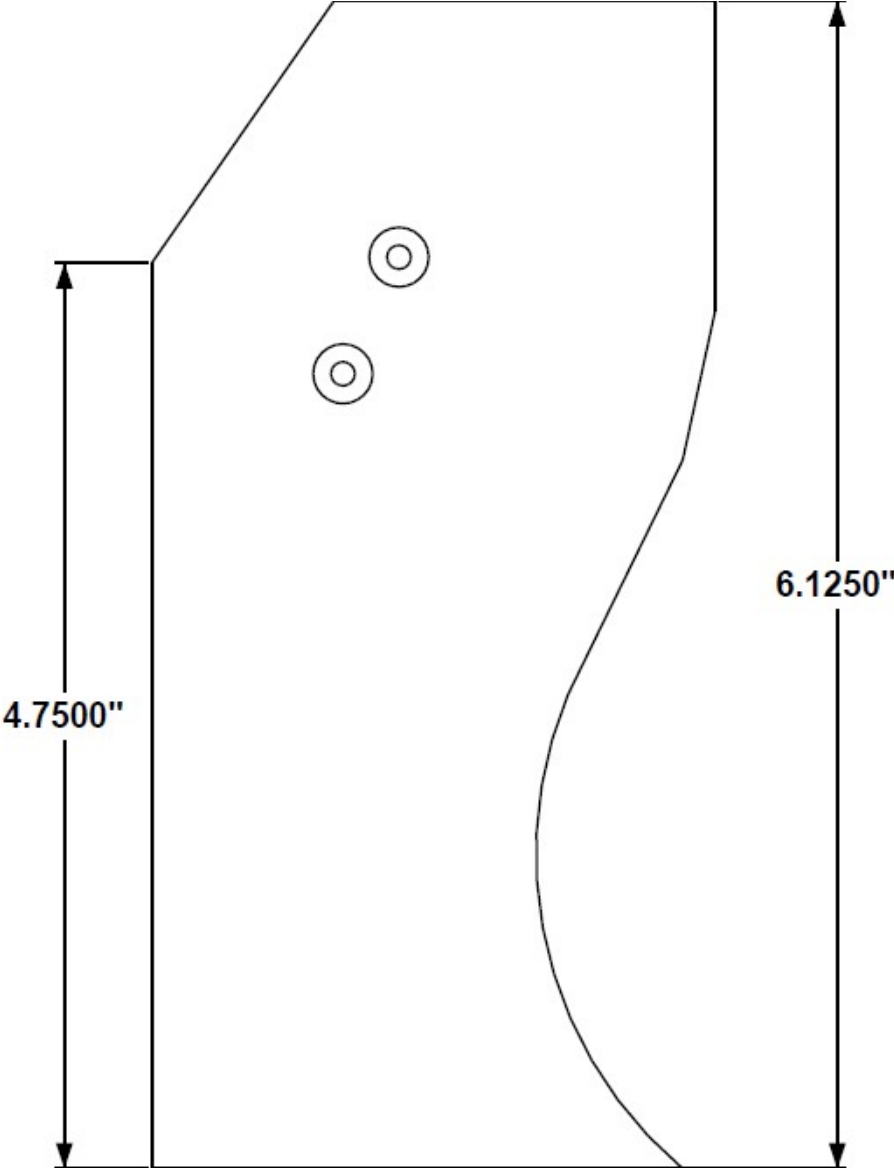

# **HARDWARE LIST**

**(Internal Use Only)**

- (4) 3/8-16 X 1" Allen Bolts (Mount to Bike)**
- (4) 5/16-18 X 3/4" Button Head bolts with nylon nuts (Top Mount holes on Legs)**
- (4) 5/16-18 X 3/4" Hex Head bolts with nylon nuts (Bottom Mount holes on Legs)**
  
- (2) 5/32" Black Air Line, 5 Foot long**
- (2) 5/32" Black Air Line, 2 Foot Long (Valve to Bulkhead or Unions)**
- (2) 5/32" 90 Degree Bulkhead Fittings (Hard Bags Only)**
- (2) 5/32" Union Fittings (Soft Bags Only)**
  
- (1) 10-24 X 2 1/4" Stainless Allen with Spacer (7/8"X3/8", Mount for Handlebar Switch no Bracket)**
- (1) 10-32 Nylon Acorn – Cover excess thread on Mount Bolt**
  
- (1) 10-32 X 1 1/4" Stainless Allen (Mount Handlebar Switch to Bracket)**
- (2) 1/4-20 X 2" Chrome Allen Bolts w Split Washers (HB Bracket 2014-UP & 95-Down)**
- (2) 1/4" X 7/16" X 7/8" Spacers (HB Bracket 2014-UP & 95-Down)**

**Wire Ties, self-adhesive clips.**

**Remove Handlebar Plug and tape to wires**