

## BALL MOUNT ASSEMBLY

### HITCH BALL

Thread desired **Hitch Ball** into the Ball Mount. Apply a generous portion of **All-Purpose Grease** along the top surface of the **Ball Mount Collar**.

*The shoulder of the Hitch Ball should rest slightly above the top of the collar.*

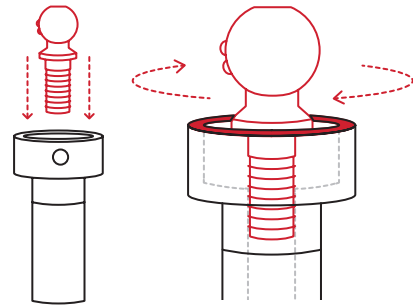

## HITCH BALL INSTALLATION

### WELD SPOTS

Insert the assembled Ball Mount into the Hitch and lock as normal.

Make sure the **Weld Spots** on the Hitch Ball are pointed towards the **rear left side of your trailer** at about **10 o'clock**.

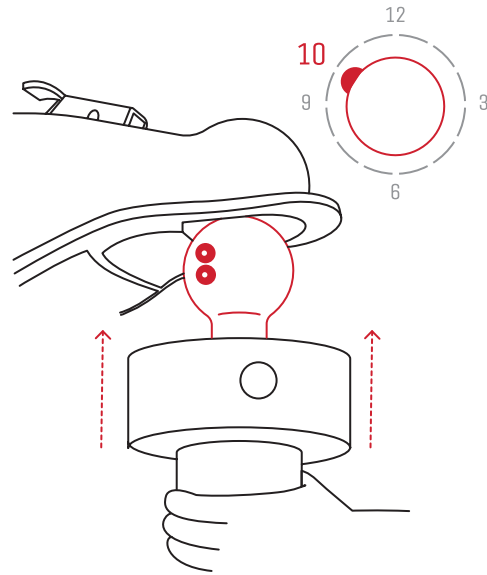

### HITCH CONNECTION

Turn the Ball Mount **Counterclockwise** until the gap between the Ball Mount Collar and Trailer Tongue closes **tightly, with no gap**.

**FLUSH,  
TIGHT,  
NO GAP**

Have a **Gap** or **Step Down Hitch** preventing a flush connection?  
**SEE THRUST WASHER**



## TIGHTEN THE BALL MOUNT

### TIGHTENING BAR

Once the Ball Mount is secure, use the **Tightening Bar** to ensure the connection is **as tight as possible!**

*This will take a few rotations.*

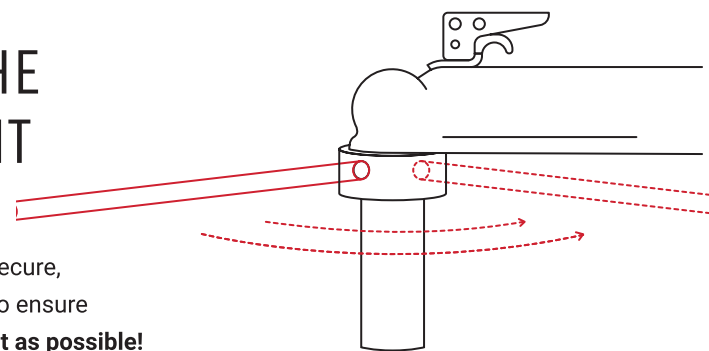

## ! SAFETY WARNING

**OPERATING WITH A LOOSE OR UNEVEN CONNECTION CAN CAUSE DAMAGE TO YOUR TRAILER OR PERSONAL INJURY.**

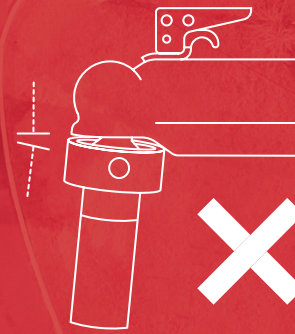

## CONNECTION GAP?

### THRUST WASHER WITH PUZZLE PIECE

Space between the Ball Mount and Coupler?  
Install the **Thrust Washer** on top of the Ball Mount with the **Puzzle Piece** installed.

*Tighten the Ball Mount as normal.*

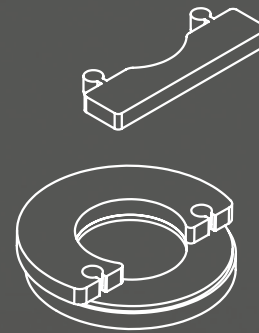

## STEP DOWN HITCH?

### THRUST WASHER

Have an obstruction preventing a flat connection?  
Place the **Thrust Washer** on top of the Ball Mount with the **open section facing the trailer**.

*While tightening, hold the Thrust Washer in place to prevent it from spinning.*

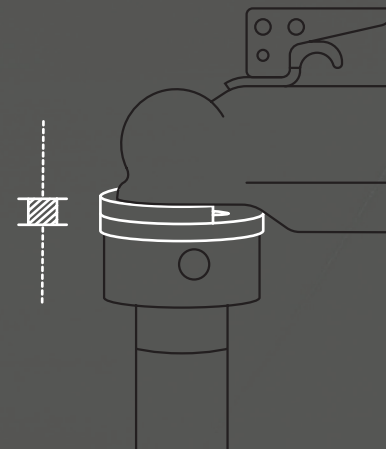

**! DANGER** DO NOT EXCEED THE SCOUT'S MAXIMUM WEIGHT CAPACITY:  
**3,000 LBS GVWR / 300 LBS TONGUE**

USE TRAILER WHEEL CHOCKS DURING THE CONNECTION PROCESS AND AFTER MOVING THE TRAILER.

USE ON FLAT, EVEN SURFACES. RISK OF RUNAWAY TRAILER. DO NOT OPERATE ON INCLINES STEEPER THAN 3%.

DO NOT OVERREACH. KEEP PROPER FOOTING, BALANCE AND POSTURE DURING OPERATION TO AVOID SELF INJURY.

## ALIGN THE DOLLY

Position the Dolly underneath the trailer's hitch. Align the base of the **Adapter** with the top of the Dolly's **Receiver Tube**.

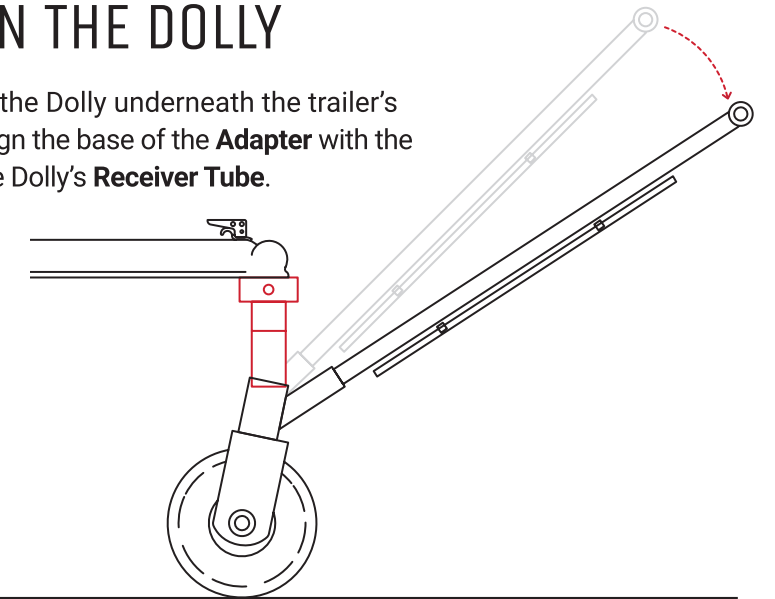

## INSERT ADAPTER

Ensure that the **Trailer is Level** and that **Wheel Chocks** are in place. Use the **Trailer Jack Stand** to fully lower the Ball Mount into the **Receiver Tube**.

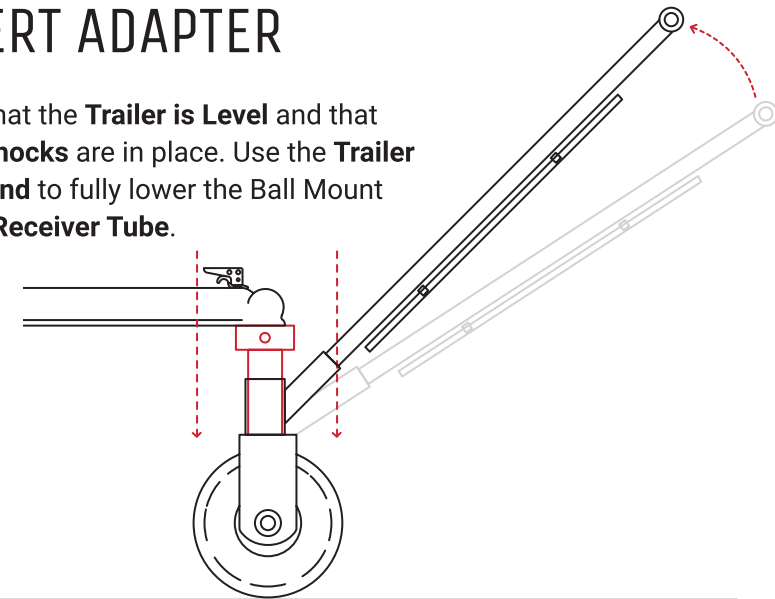

## RE-TIGHTEN BALL MOUNT

Wiggle the handle to ensure the Ball Mount is fully inserted. **Re-tighten the Ball Mount 2-3 times**, or until you can't tighten anymore.

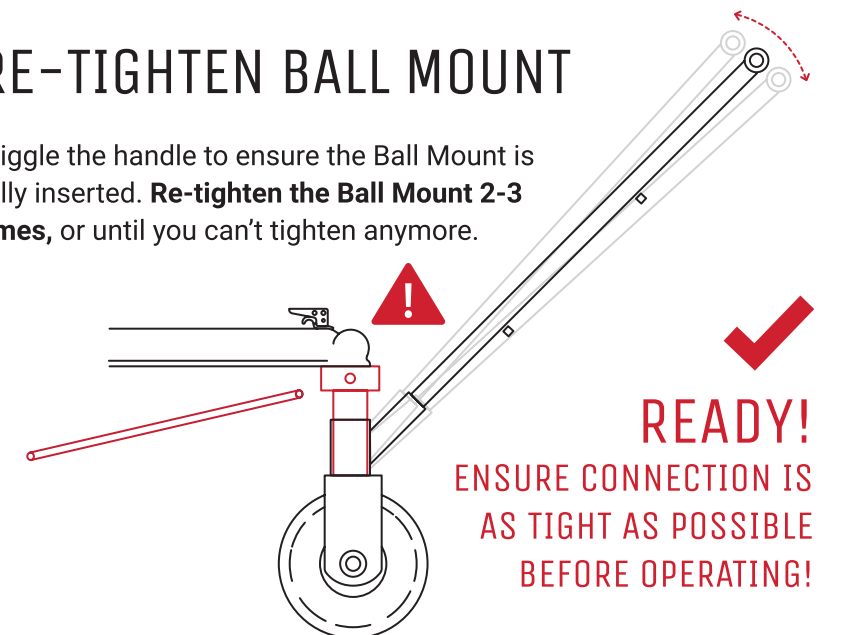

**READY!**  
ENSURE CONNECTION IS AS TIGHT AS POSSIBLE BEFORE OPERATING!

## PARKING YOUR TRAILER

Steer within inches of any obstacle and turn on a dime with the Scout's compact, single-wheel design. Our custom 8" pneumatic tire is ideal for flat, level surfaces like firm grass, packed gravel and asphalt. Use this manual Trailer Dolly at home or on the go to save time and energy! Never attempt to park the trailer on a hill or inclined surface.

## DISCONNECTING THE HITCH

Once you're finished parking, **Chock your Trailer's Wheels** to prevent a runaway trailer. **Raise the Trailer** to withdraw the **Ball Mount**.

*This adapter can be removed or left on the hitch for later use.*

## STORAGE & MAINTENANCE

Freewheel or carry the Dolly to your desired storage area, preferably under cover. Conveniently store in your trailer's storage compartment or garage for easy access.

**Before each use:** Top up the tire pressure to a maximum of **30 PSI** for a safe, reliable parking experience every time.

**Annual maintenance:** Grease the Receiver Tube and Hitch Ball Threads with **All Purpose Grease**. This can be done more often if used more frequently.

## QUESTIONS? CALL TOLL-FREE: 1-888-926-5517

NAME \_\_\_\_\_

PURCHASE DATE \_\_\_\_\_

ORDER # \_\_\_\_\_

## 2 YEAR PARTS & REPAIR WARRANTY

Your Parkit360 Dolly is covered for 2 years from the initial date of purchase. If a defect is found during this time, contact us with the original sales receipt number and details of the fault encountered.

Our Technical Support will attempt to solve the issue remotely. If the issue appears to be caused by defective parts, we will provide free replacement parts, excluding shipping costs.

If the 2 Year Warranty has expired or if you are not the original owner, you will have to pay the cost of parts and shipping. This repair will be covered for 3 months, starting 7 days from the date of shipment.

The Repair Warranty will expire either at the end of the 3 month period, or at the expiration of the original 2-Year Warranty, whichever is later.

## 30 DAY RETURN POLICY

If a material defect is found or if the Parkit360 has failed to perform to your expectations, return it within 30 days of the date of sale for a refund, less the flat shipping cost of \$100 USD.

Pack the Dolly and all included parts back into the box that it came in. Call us at 1-888-926-5517 EXT.1 to let us know about your return. Please provide us with your Sales Receipt or Online Order number.

Our staff will provide you with an RMA# that must be written on the box prior to sending. We will email you a Return Shipping Label that must be affixed to the box prior to drop off at your nearest FedEx Depot. (If you are unable to drop off the Unit, Pick-Up can be arranged.)

Receive your refund minus the shipping and restocking fee once the Dolly arrives at our warehouse.

## EXCLUSIONS AND LIMITATIONS

The 2 Year Warranty and 30 Day Return Policy do not cover:

- Normal wear and tear of the Parkit360 from use
- Shipping Costs for Returns / Repairs
- Customer Neglect and Improper Use or Storage of the Parkit360
- Modified Dollies, or if the Serial Number has been altered or removed

## DON'T RETURN TO SELLER

CALL TOLL-FREE:

1-888-926-5517 EXT. 1

# SCOUT

## MANUAL TRAILER DOLLY

ASSEMBLY & INSTALLATION V1.0



## IN THE BOX

Scout Dolly with 8" Pneumatic Tire  
20" Ball Mount  
Tightening Bar  
Two Hitch Balls: 2" & 2 5/16"  
Thrust Washer (Puzzle)  
T-Handle Shaft  
Handle Hardware Kit:

- 2 Spring Clips
- Allen Key & Screws
- 2 Washers

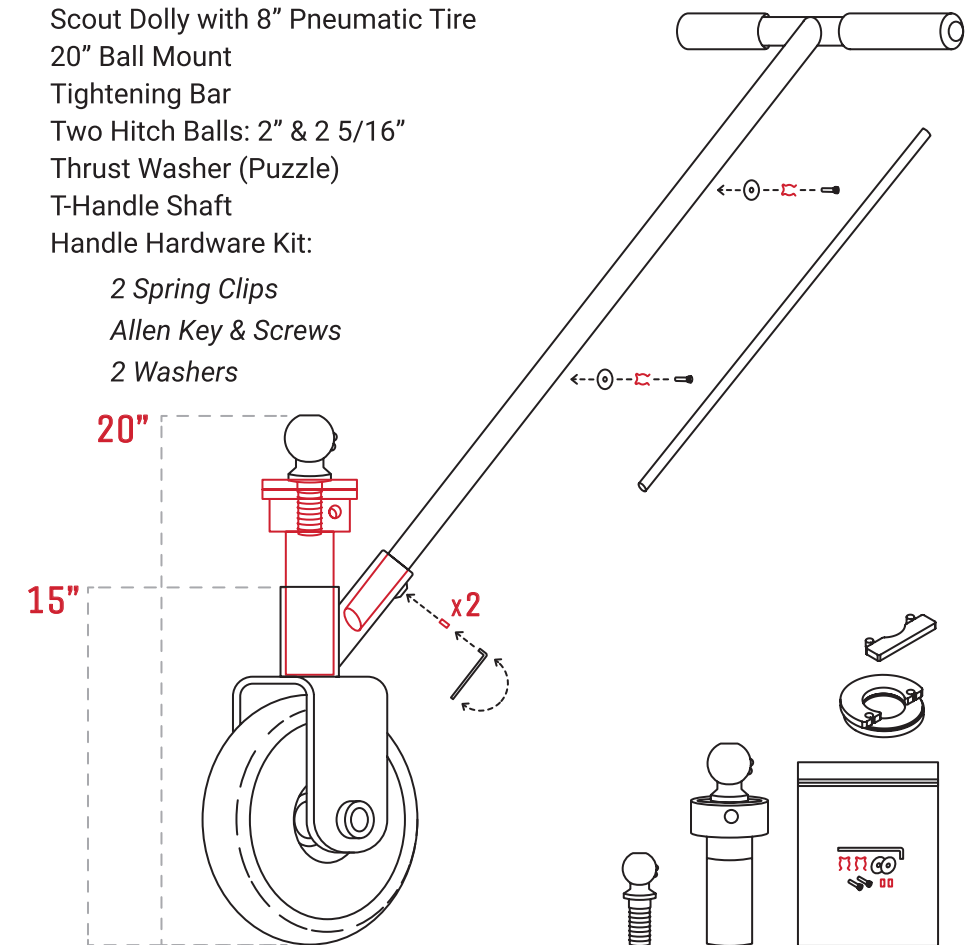

## READ CAREFULLY BEFORE OPERATION

IMPROPER USE OF THIS DOLLY CAN  
CAUSE DAMAGE TO YOUR TRAILER,  
PERSONAL INJURY OR EVEN DEATH.



PARKIT360 INC.

130 Industrial Ave, Unit 600  
Carleton Place, ON K7C 3T2 Canada  
1-888-926-5517 or Parkit360.ca