

Quilter™

Performance Amplification

TONE BLOCK



OWNER'S MANUAL

© 2013 QUILTER LABS, LLC. ALL RIGHTS RESERVED
QUILTER AND THE QUILTER LOGO ARE TRADEMARKS OF QUILTER LABORATORIES, LLC

IMPORTANT SAFETY INSTRUCTIONS

- 1 – Read and keep these instructions.
- 2 – Heed all warnings and follow all instructions.
- 3 – **WARNING:** To prevent fire or electric shock, do not expose this equipment to rain or moisture. Do not use this apparatus near water.
- 4 – Clean only with a dry cloth.
- 5 – Do not install near any heat sources such as radiators, heat registers, stoves, or other apparatus (including amplifiers) that produce heat.
- 6 – Do not defeat the safety purpose of the polarized or grounding-type plug. A polarized plug has two blades with one wider than the other. A grounding plug has two blades and a grounding prong. The wide blade or third prong are provided for your safety. If the provided plug does not fit your outlet, consult an electrician for the replacement of the obsolete outlet.
- 7– Protect the power cord from being walked on or pinched, particularly plugs, convenience receptacles, and the point where they exit from the apparatus.
- 8 – Unplug the apparatus during lightning storms or when unused for long periods of time.
- 9 – The appliance coupler (or attachment plug) is the mains disconnect device and should remain readily accessible when amplifier is in use.
- 10 – Refer all servicing to qualified service personnel. Servicing is required when the apparatus has been damaged in any way, such as power supply cord or plug is damaged, liquid has been spilled or objects have fallen into the apparatus, the apparatus has been exposed to rain or moisture, does not operate normally, or has been dropped.
- 11 – This device complies with Part 15 of the FCC Rules. Operation is subject to the following two conditions: (1) this device may not cause harmful interference, and (2) this device must accept any interference received, including interference that may cause undesired operation.
- 12 – Changes or modifications made by the user that are not expressly approved by the manufacturer may void your authority to operate the amplifier.

Explanation of Symbols



The lightning flash with arrowhead symbol within an equilateral triangle is intended to alert the user to the presence of uninsulated "dangerous" voltage within the product's enclosure that may be of sufficient magnitude to constitute a risk of electric shock to humans.



The exclamation point within an equilateral triangle is intended to alert the user to the presence of important operating and maintenance (servicing) instructions in this manual.



CAUTION: TO REDUCE THE RISK OF ELECTRIC SHOCK, DO NOT REMOVE THE COVER. NO USER-SERVICEABLE PARTS INSIDE. REFER SERVICING TO QUALIFIED PERSONNEL.



WARNING: To prevent fire or electric shock, do not expose this equipment to rain or moisture.

Forward by Patrick Quilter

The Tone Block 200 personal power amplifier provides an ideal link between a musician's electronic tone source (pedal board, digital processor, or keyboard) and practically any professional backline speaker. Despite its small size and streamlined 3-knob control panel, this little powerhouse can replace almost any stage amp ever made. The **INPUT** accepts normal guitar cables. The **GAIN** control ranges from line level to overdrive. A single **CONTOUR** control blends three distinct voices, providing far more tone shaping than an ordinary "tone" control. The **MASTER** control adjusts the amplifier's warm, musical power output from 0 to a full 200 watts, offering clean headroom and/or rich overdrive at will. The **DIRECT OUT** provides an easy interface to stage or studio audio systems. A rack mount kit is also available, mounting one or two Tone Blocks in a 2RU rack adaptor.

Please consult this manual to obtain the best results.

Our goal at Quilter Labs is to use the latest power technology to maximize warmth and dynamics without the weight and drawbacks of classic tube technology. No shortcuts have been taken in the design and manufacturing. Every component and circuit is selected solely on the basis of superior results. Where advanced design or premium components significantly boost performance, we have made the investment. Costs are kept as low as possible using a well-managed high volume production process.

The result is a serious professional tool with performance that meets or beats handmade amps costing and weighing several times as much.

We hope you enjoy your new amplifier. May it deliver many years of flawless service and provide a source of inspiration and creativity.

Carton Contents

- 1 Quilter Tone Block Amplifier
- 1 IEC AC Power Cord
- 1 Owner's Manual

FRONT PANEL:

INPUT: Accepts standard guitar or any other signal.

GAIN: The left half of the range is suitable for line-level signals such as keyboards, mixer outputs, or external pre-amps. The right half of the range will produce increasing amounts of overdrive.

CONTOUR: The frequency response is flat, or neutral, in the middle. The left end of the control accesses a “scooped” EQ with full treble and bass, but less midrange, often used for greater “chime” and clarity. The right end of the control accesses a midrange-treble boost with reduced bass, often used for a more forward lead-guitar effect. These three main voices are blended smoothly on in-between settings.

MASTER: Sets the overload or clipping point of the amplifier, from zero to 200 watts, approximately as shown on the panel. The overdrive “feel” resembles vintage amps, with gradual breakup leading to lots of sizzle.

DIRECT OUT: Provides a mic-level, isolated signal that may be used instead of placing a microphone in front of the speaker. The signal is equalized to match the response of most cone-type speakers.



REAR PANEL – AC POWER, SPEAKERS

International Power Supply

The Tone Block works with all known worldwide AC voltages (100-250V), which allows you to play just about anywhere on the planet.

Locking IEC Power Cord

The power cord that comes with your amplifier is designed to lock into the AC inlet to reduce the chance it will come unplugged during use. Press the yellow button on the cord to release it. Any normal 3-prong IEC cord may also be used with the amplifier. Always ensure that the ground contact is intact on both the cord and receptacle.



Speaker Outputs

Connect a single 8-ohm speaker to the lower jack, marked 8-OHMS.

Connect a single 4-ohm speaker to the upper jack, marked 4-OHMS.

For two 8-ohm speakers, plug one into each jack. Power will divide equally between the two speakers.

The amplifier will adjust the output impedance and tone balance automatically. Other impedances may be connected, but the tone may change somewhat and the front-panel wattage markings may no longer be accurate.

CAUTION: The Tone Block can provide enough power to blow many popular speakers. For safer results, use the MASTER to select a wattage limit that is reasonable for the speaker being used.



MOUNTING THE TONE BLOCK.

Multiple holes are provided in the cover to enable the Tone Block to be mounted in a variety of situations. The rubber feet may be removed if desired; save the mounting screws for re-use to ensure proper fit and retention.

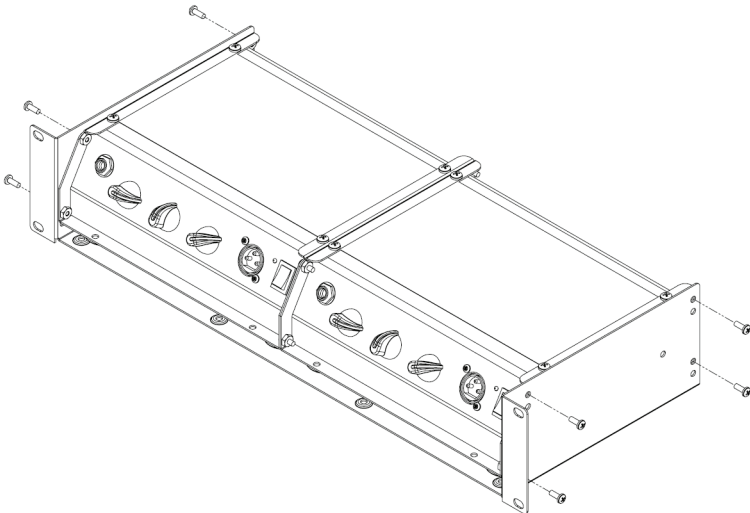
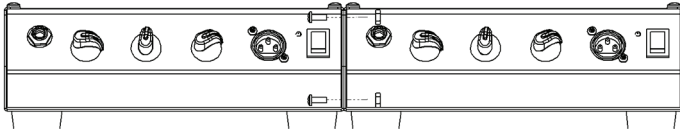
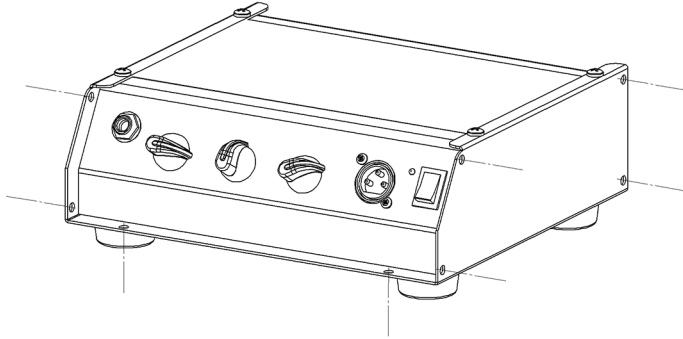



Caring For Your Amplifier

Clean the outer surfaces with a clean, damp cloth or vacuum with a soft brush. Never use any abrasives, harsh cleaners or solvents. The Tone Block amplifier is manufactured with high quality components using modern industrial processes that greatly reduce production defects. Each amplifier goes through an intensive testing process before it leaves the factory ensuring that your amplifiers will give you years of flawless service. There are no user-serviceable parts inside the amplifier. Any repairs should be performed by a trained service professional. Always use the amplifier in a well-ventilated environment and protect from external heat sources such as furnaces or direct sunlight. Prolonged high-volume playing causes heat buildup in the speaker which reduces its working lifetime. If you find it necessary to consistently use the amp at full volume, we recommend using an extension speaker to prolong speaker life and improve sound coverage.

Specifications

| ELECTRONIC PERFORMANCE: | |
|--------------------------------|---|
| Power Output: | 0 to 200 watts, 4-8 ohms |
| AC Power Req.: | 100–240Vac, 50–60 Hz, 250 W |
| Input Connections: | ¼" mono |
| Input Impedance: | 2M ohms |
| Direct Out: | XLR-M, 300mv full scale, balanced, ground lifted 10K min. |
| Speaker 1 Output: | 8 ohms, 200 W minimum rating |
| Speaker 2 Output: | 4 ohms, 200 W minimum rating |
| Dual Speakers 1+2 | 8 ohms each. |
| DIMENSIONS | |
| H x W x D | 2.5" (6.35cm) x 8.4" (21.3cm) x 7.2" (18.3cm) |
| Weight | 4 lbs (1.8kg) |

Troubleshooting

| Symptom | Action |
|--|--|
| No power, no lights | <ul style="list-style-type: none"> • Ensure that the AC cord is fully seated and connected to a live source. • Check the AC source by trying another device such as a lamp. |
| Amp shuts off then after a short time, turns back on | <ul style="list-style-type: none"> • Automatic thermal protection is activating. Reduce the volume at least 30% and keep the amplifier out of direct sunlight or tightly enclosed spaces. • Continued intermittent behavior indicates need for servicing. |
| No audio (using a guitar) | <ul style="list-style-type: none"> • Confirm that the MASTER control and the <u>GAIN controls</u> are turned up. • Ensure the guitar plug is inserted fully at each end. • Try using a different guitar cable. • Check that the pickup selector switch and volume on the guitar are set correctly. • Ensure that the rear panel speaker plug is fully inserted into the INT SPEAKER jack. |
| Weak or fluctuating audio | <ul style="list-style-type: none"> • Check connections and power supply or batteries in pedal board. • The amplifier almost never "loses power" without completely stopping. Look for external causes. |

Troubleshooting

| | |
|--|--|
| Background hum | <ul style="list-style-type: none"> • Ensure the guitar plug is fully inserted. • Try using a different guitar cable. Make sure it is properly shielded. • Any AC powered sources or effects should be plugged into the same receptacle as the amplifier to help avoid ground loops. <p>If the hum goes away when you turn down the guitar:</p> <ul style="list-style-type: none"> • Single coil pickups can be a source of hum, especially if near RF sources like light dimmers or neon lights. Some guitars have a mode where two pickups are in reverse polarity to each other. This mode can often reduce hum. • Check that the guitar's cavities are well shielded. |
| Excessive noise | <ul style="list-style-type: none"> • At high gain settings, some audible hiss or whoosh is normal. • Check your cables, guitar and other effects in the signal chain, especially for hum or buzz. |
| Amp sounds garbled at all volumes | <ul style="list-style-type: none"> • Check speaker by temporarily trying an external speaker. Caution: reduce MASTER volume until sound level has been confirmed. • Try plugging instrument directly into the amp, bypassing outboard processing. If sound is then clean, check outboard processing for problems. |
| Desire clean tone, getting too much overdrive | <ul style="list-style-type: none"> • Turn down the GAIN control and turn up MASTER. |
| Desire overdrive tone, not getting enough overdrive | <ul style="list-style-type: none"> • Turn down MASTER and increase GAIN until the desired overdrive is obtained, then reset MASTER to desired loudness. • Turn up guitar volume. • Try higher output pickups. |
| Tone sounds "dull" with no high frequencies | <ul style="list-style-type: none"> • Confirm EQ settings. • Check your guitar's tone controls. |
| <p>Amplifier Requires Service</p> <p>If any of the below occur, immediately unplug the amplifier and refer to a service technician.</p> <ul style="list-style-type: none"> • Amplifier or AC cord emits smoke • Amplifier is dropped or chassis is dented or bent • Liquid has been spilled into the amplifier • Loose parts inside the amplifier are heard • AC breaker trips | |



LIMITED TRANSFERABLE WARRANTY

IMPORTANT: PLEASE READ THIS DOCUMENT COMPLETELY. IT CONTAINS IMPORTANT INFORMATION ABOUT YOUR RIGHTS AND OBLIGATIONS, AS WELL AS LIMITATIONS AND EXCLUSIONS THAT MAY OR MAY NOT APPLY TO YOU. BY ACCEPTING DELIVERY OF THE PRODUCT(S), YOU AGREE TO BE BOUND BY AND ACCEPT THESE TERMS AND CONDITIONS.

Quilter Laboratories, LLC (Quilter Labs) guarantees its products to be free from defective material and/or workmanship and will replace defective parts and repair malfunctioning products under this warranty when the defect occurs under normal installation and use provided the unit is returned to our factory via pre-paid transportation with a copy of proof of purchase. (i.e. sales receipt). This warranty provides that the examination of the return product must indicate, in our judgment, a manufacturing defect. This warranty does not extend to any product which has been subjected to misuse, neglect, accident, or where the date code or serial number has been defaced or removed. Quilter Labs shall not be liable for incidental and/or consequential damages. This warranty gives you specific legal rights.

This limited warranty is freely transferable during the term of the warranty period. The warranty on Quilter products is NOT VALID if the products have been purchased from an unauthorized dealer/online

e-tailer, or if the factory serial number has been removed, defaced, or replaced in any way.

Customers may have additional rights, which vary from state to state or from country to country. In the event that a provision of this limited warranty is void, prohibited or superseded by local laws, the remaining provisions shall remain in effect. The Quilter Labs limited warranty in the United States is valid for a period of three (3) years from date of purchase except that footswitches, covers, cabinets, handles, and cabinet hardware are warranted for a period of one (1) year and speakers, and all other included accessory products for a period of ninety (90) days from date of purchase.

IMPORTANT: PLEASE RETAIN YOUR SALES RECEIPT OR ONLINE ORDER RECORD, AS IT IS YOUR PROOF OF PURCHASE COVERING YOUR LIMITED



WARRANTY. TO TRANSFER THE WARRANTY TO A SUBSEQUENT PURCHASER, YOU MUST ENDORSE THE SALE OF THE PRODUCT TO THE SUBSEQUENT PURCHASER ON THE FRONT OF THE SALES RECEIPT. THIS LIMITED WARRANTY IS VOID WITHOUT SUCH ENDORSED SALES RECEIPT.

Defective products that qualify for coverage under this warranty will be repaired or replaced, (at Quilter Labs' discretion) with a like or comparable product, without charge. To receive warranty service, return the complete product to Quilter Labs, LLC, with proof of purchase, during the applicable warranty period. The Quilter Labs Dealer from whom you purchased your product may also be authorized for warranty service and should be the first point of contact when service is required. TRANSPORTATION COSTS ARE NOT INCLUDED IN THIS LIMITED WARRANTY. Any repair or service performed by any person or entity other than an Authorized Quilter Labs Electronics Service Center is not covered by this limited warranty. Other questions regarding this warranty can be answered by calling (714) 519-6114 or by contacting your authorized Quilter distributor. Email: info@quilterlabs.com

Factory Service

To return an amplifier to Quilter Labs for service under the warranty policy, please visit www.quilterlabs.com and fill out the Return Request Form. If you do not have access to the website, you may send a request by letter to Quilter Labs at 1700 Sunflower, Suite A, Costa Mesa, CA 92626. Please include the serial number of the amplifier and a copy of your sales receipt. Instructions on how to send your amplifier will be provided. Do not attempt to open the amplifier and service it yourself. Any attempt to service the amplifier by a non-authorized service technician may void your warranty.

Note: This equipment has been tested and found to comply with the limits for a Class B digital device, pursuant to part 15 of the FCC Rules. These limits are designed to provide reasonable protection against harmful interference in a residential installation. This equipment generates, uses, and can radiate radio frequency energy and, if not installed and used in accordance with the instructions, may cause harmful interference to radio communications. However, there is no guarantee that interference will not occur in a particular installation. If this equipment does cause harmful interference to radio or television reception, which can be determined by turning the equipment off and on, the user is encouraged to try to correct the interference by one or more of the following measures:

- Reorient or relocate the receiving antenna.
- Increase the separation between the equipment and receiver
- Connect the product into an outlet on a circuit different from that to which the receiver is connected.
- Consult the dealer or an experienced radio/TV technician for help.



P/N 000499 REV C.