



Juliet's Love Shrug

Since this little cropped sweater can be worn with everything from jeans to a party dress, it's perfect for meeting your Romeo at any occasion. Sashay yarn provides a sparkly ruffle that's fun to wear.

Designed by Julie Farmer.

Directions are for size Small. Changes for sizes Medium, Large, 1X, 2X and 3X are in parentheses.

To Fit Bust/Chest: 32 (36, 40, 44, 48, 52)"

Finished Chest: 35 (39, 43, 47, 51, 55)"

Finished Length: 14 (14½, 15, 16½, 17½, 18½)", not including neckband and not including ruffle

RED HEART® Soft™: 3 (3, 4, 5, 5, 6) balls 3729 Grape A.

RED HEART® Boutique™ Sashay: 1 (1, 1, 2, 2, 2) balls 1943 Tango B.

Knitting needles: 5mm [US 8], 4mm [US 6].
Stitch holders, stitch markers (optional), yarn needle.

GAUGE: 17 sts = 4"; 23 rows = 4". **CHECK YOUR GAUGE.** Use any size needles to obtain the gauge.

Special Stitches

M1 = Make 1 (Increase) – Lift strand between needles to left-hand needle and knit strand through the back loop, twisting it to prevent a hole.

ssk = slip next two stitches knitwise to right needle, insert point of left needle through front of sts, knit these sts together through back loop.

Special Technique

3-Needle Bind-Off = Hold needles of stitches to be seamed parallel and with Right Sides together, with 3rd needle knit together first stitch from each needle, *knit together next stitch from each needle, pass 2nd stitch over first stitch and off right needle; repeat from * until all stitches have been knit from the 2 parallel needles and only one stitch remains on the right needle. Fasten off.

PATTERN STITCH

Seed Stitch (multiple of 2 sts)

Row 1 (Right Side): *K1, p1; repeat from * across.

Row 2: *P1, k1; repeat from * across.

Repeat Rows 2 and 3 for Seed st.

NOTES

Shrug is worked in once piece, from lower edge up to armholes. Piece is then divided for armholes, and back and fronts worked separately to shoulders. Sleeves are worked separately.

Four edge stitches are worked in Seed stitch. You may wish to place markers to separate these stitches from the Stockinette stitch middle section.

SHRUG

Body

With larger needles and **A**, cast on 148 (168, 184, 200, 216, 236) sts.

Row 1 (Right Side): [K1, p1] 2 times, knit to last 4 sts, [k1, p1] 2 times.

Row 2: [P1, k1] 2 times, purl to last 4 sts, [p1, k1] 2 times. Keeping first and last 4 sts in Seed st, work even in St st (knit on Right Side, purl on Wrong Side) until piece measures about 6 (6, 6, 7, 7, 8)" from beginning, end with a Wrong Side row.



Divide for Fronts and Back

Next Row (Right Side): [K1, p1] 2 times, k33 (38, 42, 46, 50, 55) sts, slip these first 37 (42, 46, 50, 54, 59) sts onto a holder for right front, bind off next 4 (6, 7, 8, 9, 11) sts for armhole, knit across next 70 (78, 85, 92, 99, 107) sts, slip last 37 (42, 46, 50, 54, 59) sts onto a holder for left front, TURN.

Next Row (Wrong Side): Bind off 4 (6, 7, 8, 9, 11) sts for armhole, purl across remaining 66 (72, 78, 84, 90, 96) sts for back.

Back

Working over back sts only.

Shape Armholes

Next Row (Right Side): K1, k2tog, knit to last 3 sts, ssk, k1—64 (70, 76, 82, 88, 94) sts.

Next Row: Purl.

Repeat last 2 rows 3 (5, 6, 7, 8, 10) more times—58 (60, 64, 68, 72, 74) sts.

Work even in St st until piece measures about 14 (14½, 15, 16½, 17½, 18½)" from beginning, end with a Wrong Side row.

Shape Neck

Next Row (Right Side): K15 (16, 17, 18, 19, 20) sts for right shoulder, bind off next 28 (28, 30, 32, 34, 34) sts for neck, knit to end of row for left shoulder. Cut yarn and place sts onto a holder.

Right Front

With Wrong Side facing, return right front sts to needle—37 (42, 46, 50, 54, 59) sts.

Shape Armhole

Next Row (Wrong Side): Bind off 4 (6, 7, 8, 9, 11) sts, purl to last 4 sts, [p1, k1] 2 times—33 (36, 39, 42, 45, 48) sts.

Next Row (Right Side): [K1, p1] 2 times, knit to last 3 sts, ssk, k1—32 (35, 38, 41, 44, 47) sts.

Next Row (Wrong Side): Purl to last 4 sts, [p1, k1] 2 times. Repeat last 2 rows 3 (5, 6, 7, 8, 10) more times—29 (30, 32, 34, 36, 37) sts.

Keeping 4 sts at front edge in Seed st, work even in St st until piece measures about 11½ (12, 12½, 13, 13½, 14½)" from beginning, end with a Wrong Side row.

Shape Neck

Next Row (Right Side): Bind off 7 (7, 8, 6, 7, 7) sts, knit to end of row—22 (23, 24, 28, 29, 30) sts.

Next Row: Purl.

Next Row: Bind off 2 sts, knit to end of row—20 (21, 22, 26, 27, 28) sts.

Next Row: Purl.

Repeat last 2 rows 0 (0, 0, 1, 1, 1) more time(s)—20 (21, 22, 24, 25, 26) sts.

Next Row (Right Side): K1, k2tog, knit to end of row—19 (20, 21, 23, 24, 25) sts.

Next Row: Purl.

Repeat last 2 rows 4 (4, 4, 5, 5, 5) times—15 (16, 17, 18, 19, 20) sts.

Work even in St st until piece measures about 14 (14½, 15, 16½, 17½, 18½)" from beginning.

Left Front

With Right Side facing, return right front sts to needle—37 (42, 46, 50, 54, 59) sts.

Shape Armhole

Next Row (Right Side): Bind off 4 (6, 7, 8, 9, 11) sts, knit to last 4 sts, [k1, p1] 2 times—33 (36, 39, 42, 45, 48) sts.

Next Row (Wrong Side): [P1, k1] 2 times, purl to end of row.

Next Row (Right Side): K1, ssk, knit to last 4 sts, [k1, p1] 2 times—32 (35, 38, 41, 44, 47) sts.

Repeat last 2 rows 3 (5, 6, 7, 8, 10) more times—29 (30, 32, 34, 36, 37) sts.

Keeping 4 sts at front edge in Seed st, work in St st (knit on Right Side, purl on Wrong Side) until piece measures about 11½ (12, 12½, 13, 13½, 14½)" from beginning, end with a Right Side row.

Shape Neck

Next Row (Wrong Side): Bind off 7 (7, 8, 6, 7, 7) sts, purl to end of row—22 (23, 24, 28, 29, 30) sts.

Next Row: Knit.

Next Row: Bind off 2 sts, purl to end of row—20 (21, 22, 26, 27, 28) sts.

Next Row: Knit.

Repeat last 2 rows 0 (0, 0, 1, 1, 1) more time(s)—20 (21, 22, 24, 25, 26) sts.

Next Row: P1, p2tog, purl to end of row—19 (20, 21, 23, 24, 25) sts.

Next Row: Knit.

Repeat last 2 rows 4 (4, 4, 5, 5, 5) times—15 (16, 17, 18, 19, 20) sts.

Work even in St st until piece measures about 14 (14½, 15, 16½, 17½, 18½)" from beginning. Using 3-needle bind-off, seam shoulders.

Sleeve (Make 2)

With larger needles and **A**, cast on 48 (48, 50, 52, 60, 64) sts. Work even in Seed st for about 1", end with a Wrong Side row.

Shape Sleeve

Increase Row (Right Side): K1, M1, knit to last st, M1, k1—50 (50, 52, 54, 62, 66) sts.

Next Row: Purl.

Repeat last 2 rows 7 (11, 10, 14, 12, 17) more times—64 (72, 72, 82, 86, 100) sts.

Repeat Increase Row every other Right Side row 2 (0, 2, 0, 2, 0) times—68 (72, 76, 82, 90, 100) sts.

Work even in St st until piece measures about 5 (5, 6, 6, 7, 7)", end with a Wrong Side row.

Shape Cap

Next Row (Right Side): Bind off 4 (6, 7, 8, 9, 11) sts, knit to end of row—64 (66, 69, 74, 81, 89) sts.

Next Row: Bind off 4 (6, 7, 8, 9, 11) sts, purl to end of row—60 (60, 62, 66, 72, 78) sts.

Decrease Row (Right Side): K1, k2tog, knit to last 3 sts, ssk, k1—58 (58, 60, 64, 70, 76) sts.



JULIET'S LOVE SHRUG | KNIT

Next Row: Purl.

Repeat last 2 rows 10 (14, 14, 14, 16, 15) more times—38 (30, 32, 36, 38, 46) sts.

Repeat Decrease Row—36 (28, 30, 34, 36, 44) sts.

Next Row (Wrong Side): P1, p2tog, purl to last 3 sts, p2tog through back loops, p1—34 (26, 28, 32, 34, 42) sts.

Repeat last 2 rows 3 (0, 0, 1, 1, 2) more time(s)—22 (26, 26, 28, 28, 30, 34) sts.

Repeat Decrease Row—20 (24, 26, 26, 28, 32) sts.

Next Row (Wrong Side): Bind off 2 (3, 3, 3, 3, 4) sts, purl to end of row—18 (21, 23, 23, 25, 28) sts.

Next Row (Right Side): Bind off 2 (3, 3, 3, 3, 4) sts, knit to end of row—16 (18, 20, 20, 22, 24) sts.

Repeat last 2 rows 2 more times—12 (12, 14, 14, 16, 16) sts. Bind off.

FINISHING

Neckband

With Right Side facing, smaller needles and **A**, pick up and k7 (7, 8, 6, 7, 7) sts across bound-off edge of right front, pick up and k2 (2, 2, 4, 4, 4) sts across right side bind-off, pick up and k11 (11, 11, 14, 14, 14) sts across right neck, pick up and k28 (28, 30, 32, 34, 34) sts across back neck, pick up and k11 (11, 11, 14, 14, 14) sts across left neck, pick up and k2 (2, 2, 4, 4, 4) sts across left side bind-off, pick up and k7 (7, 8, 6, 7, 7) sts across bound-off edge of left front—68 (68, 72, 80, 84, 84) sts.

Work even in Seed st for about 1".

Bind off in pattern.

Sew sleeve seams, sew in sleeves.

Ruffle

With Wrong Side facing, larger needles and **B**, pick up and k74 (84, 92, 100, 108, 118) sts.

Next Row: Knit loosely.

Bind off very loosely.

Weave in ends.



RED HEART® Soft™ Art. E728 available in solid color 5 oz (140 g), 256 yd (234 m) and print 4 oz (113 g), 204 yd (187 m) balls.



RED HEART® Boutique™ Sashay™ Art. E782, available in multi color 3.5 oz (100g), 30 yd (27m) balls.

ABBREVIATIONS: **A, B, C** = Color A, Color B; **k** = knit; **k2tog** = knit next 2 stitches together; **p2tog** = purl next 2 stitches together; **st(s)** = stitch(es); **[]** = work directions in brackets the number of times specified; ***** = repeat whatever follows the * as indicated.

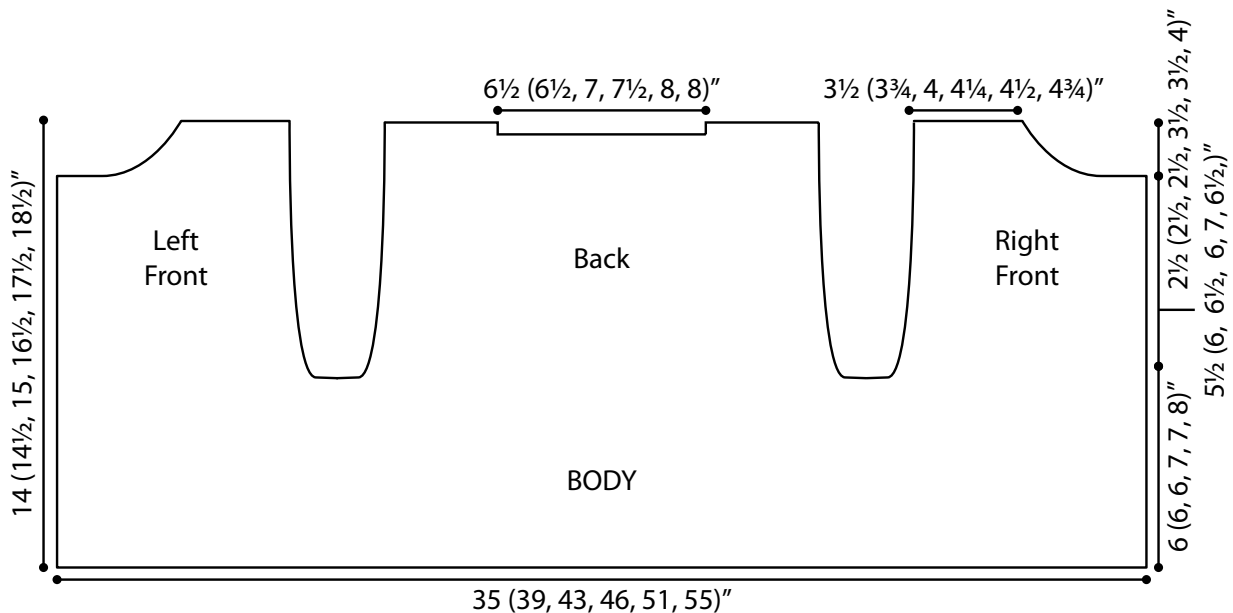
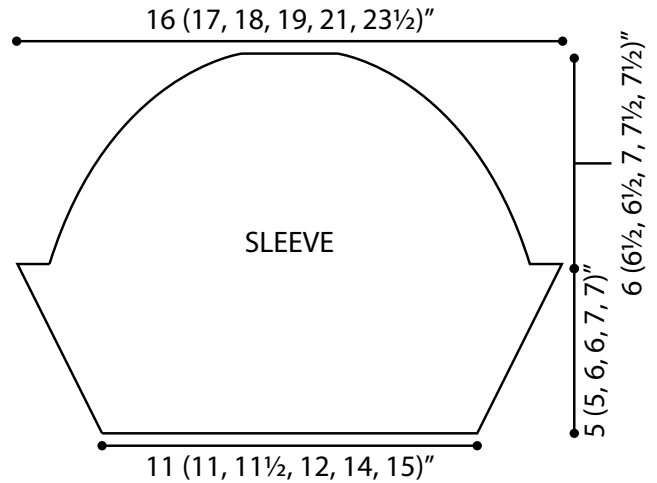



SUMMER SAILOR SWEATER | KNIT

