

Mikey
from The Crochet Crowd



CROCHET | SKILL LEVEL: INTERMEDIATE

MEASUREMENTS

- Week 1 – approx 10" [25 cm] diameter
- Week 2 - approx 18" [46 cm] diameter
- Week 3 - approx 20" [51 cm] square
- Week 4 - approx 31" [78 cm] square
- Week 5 - approx 40" [102 cm] square
- Week 6 - approx 48" [123 cm] square
- Week 7 - approx 54" [137 cm] square

GAUGE

12 sc and 13 rows = 4" [10 cm]

Tip from Mikey: For best results, if you need to join next ball of yarn of the same color, closely match the color from the first ball which may require you to start the second ball partially into the ball. If starting the second segment of a partially used ball, continue with the ball at the color where you finished. It will keep the colors transitioning smoothly.

Notes:

To join all rnds with sl st to first st unless otherwise it's stated.

Ch 2 at beg of rnds **does not** count as st.

Ch 3 at beg of rnds counts as dc.

MATERIALS

Red Heart® Super Saver Ombre™ (10 oz/283 g; 482 yds/440 m)

Version 1 - Yellow/Blue Sample

Contrast A Sunny (4926) **2 balls**

Contrast B Light Blue (4981) **2 balls**

Contrast C Seaside (4935) **2 balls**

Version 2 - Pink/Purple Sample

Contrast A Jazzy (3966) **2 balls**

Contrast B Anthracite (3964) **2 balls**

Contrast C Purple (3968) **2 balls**

Size U.S. H/8 (5 mm) crochet hook **or size needed to obtain gauge.**
Stitch marker. Yarn needle.

ABBREVIATIONS

Beg = Beginning

Beg Popcorn = Ch 2. 4 dc in first stitch. Drop loop from hook. Re-insert hook from front to back into top of beginning ch 2 before 4-dc group. Pull dropped loop through stitch. Ch 1 to close popcorn

Ch = Chain(s)

Cluster = (Yoh and draw up a loop. Yoh and draw through 2 loops on hook) 3 times in indicated stitch. Yoh and draw through all 4 loops on hook

Dc = Double crochet

Dc2tog = (Yoh and draw up a loop in next stitch. Yoh and draw through 2 loops on hook) twice. Yoh and draw through all 3 loops on hook

Dcbp = Yoh and draw up a loop around post of next stitch at back of work inserting hook from right to left. (Yoh and draw through 2 loops on hook) twice - 1 dcbp made

Dcfp = Yoh and draw up a loop around post of next stitch at front of work inserting hook from right to left. (Yoh and draw through 2 loops on hook) twice - 1 dcfp made

Hdc = Half double crochet

Hdc2tog = (Yoh and draw up a loop in next st) twice. Yoh and draw through all loops on hook

Petal = (1 sc. 1 hdc. 1 dc. 1 tr. 1 dc. 1 hdc. 1 sc) all in indicated stitch

Popcorn = Work 5 dc in indicated stitch. Drop loop from hook. Re-insert hook from front to back into first dc of 5-dc group. Pull dropped loop through stitch. Ch 1 to close popcorn.

Puff Stitch = (Yoh and draw up a loop) 4 times around indicated stitch. 9 loops on hook. Yoh and draw through 8 loops on hook. Yoh and draw through last 2 loops on hook. Ch 1 to close Puff Stitch

Rep = Repeat

RS = Right side

Sc = Single crochet

Sc2tog = Draw up a loop in each of next 2 sc. Yoh and draw through all 3 loops on hook

Scbp = Draw up a loop around post of next stitch at back of work inserting hook from right to left. (Yoh and draw through 2 loops on hook - 1 scbp made

Scfp = Draw up a loop around post of next stitch at front of work inserting hook from right to left. Yoh and draw through 2 loops on hook - 1 scfp made

Sl st = Slip stitch

Small dc-cluster = (Yoh and draw up a loop. Yoh and draw through 2 loops on hook) twice in indicated stitch. Yoh and draw through all 3 loops on hook

Sp(s) = Space(s)

St(s) = Stitch(es)

Standing sc = Form slip knot and insert onto hook. Insert hook into indicated stitch. Yoh and draw up a loop. Yoh draw through all 2 loops

Standing scbp = Form slip knot and insert onto hook. Insert hook into indicated stitch. Draw up a loop around post of next stitch at back of work inserting hook from right to left. (Yoh and draw through 2 loops on hook

Tr = Treble crochet

Trbp = (Yoh) twice and draw up a loop around post of next stitch at back of work inserting hook from right to left. (Yoh and draw through 2 loops on hook) 3 times

Tr-Cluster = Ch 3. [(Yoh) twice and draw up a loop. (Yoh and draw through 2 loops on hook) twice]. Yoh and draw through all 3 loops on hook

Trfp = (Yoh) twice and draw up a loop around post of next stitch at front of work inserting hook from right to left. (Yoh and draw through 2 loops on hook) 3 times

WS = Wrong side

Yoh = Yarn over hook

INSTRUCTIONS



See Diagram I on page 4.

With A, ch 3. Join with sl st to form a ring.

1st rnd: Ch 1. 6 sc in ring. Join. 6 sc.

2nd rnd: Ch 2. (Yoh and draw up a loop. Yoh and draw through 2 loops) twice in same sp as sl st. Yoh and draw through all 3 loops on hook - beg Cluster made. (Ch 3. Cluster in next sc) 5 times. Ch 3. Join with sl st to top of first cluster. 6 clusters.

3rd rnd: Ch 1. *(2 sc. Ch 2. 2 sc) in next ch-3 sp. Ch 1. Rep from * around. Join. 24 sc, 6 ch-2 sps and 6 ch-1 sps.

4th rnd: Ch 1. 1 sc in same sp as sl st. *Skip next sc. (2 dc. 1 tr. 2 dc) in next ch-2 sp. Skip next sc. 1 sc in next sc. Sl st in next ch-1 sp.** 1 sc in next sc. Rep from * 4 times more. Rep from * to ** once more. Join. Fasten off. 24 dc, 6 tr.

5th rnd: Join A with standing scbp around any tr-post. *Ch 2. Skip next (2 dc and sc). Working between (2 dc, tr, dc)- groups and over next sl st, 5 dc in top of Cluster of 2nd rnd and encase rnds 3 and 4 inside dc-sts. Ch 2.** Skip next (sc and 2 dc). 1 scbp around post of next tr. Rep from * 4 times more, then from * to ** once more. Join. 12 ch-2 sps, 6 of 5-dc groups and 6 scbp.

6th rnd: Sl st in each of next 2 ch and each of next 2 dc. Ch 1. 3 scfp around post of next (middle) dc. Skip next 2 dc and ch-2 sp. 5 dcfp around post of next tr of 4th rnd.

Note: there is already scbp attached to same post, stay below that attachment so the dcfp will cover it. *Skip next (ch-2 sp and 2 dc). 3 scfp around next dc of 5th rnd. Skip next (2 dc and ch-2 sp). 5 dcfp around next tr of 4th rnd. Rep from * around. Join. 6 groups of 5-dc and 6 groups of 3-scfp.

Tip from Mikey: The circle will go from 6 sides to 12 in next rnd.

7th rnd: Sl st in next scfp (center of 3 scfp-group). Ch 6. 1 dc in same sp as sl st. Ch 2. Skip next (scfp, 2 dcfp). (1 dc. Ch 3. 1 dc) in next dcfp (center of 5-dcfp group). Ch 2. *Skip next (2 dcfp, scfp). (1 dc. Ch 3. 1 dc) in next scfp (center of 3-scfp group). Ch 2. Skip next (scfp, 2 dcfp). (1 dc. Ch 3. 1 dc) in next dcfp (center of 5-dcfp group). Ch 2. Rep from * around. Join with sl st to 3rd ch of ch 6. 12 (1 dc. Ch 3. 1 dc) groups and 12 ch-2 sps.

8th rnd: Sl st in next ch-3 sp. Ch 1. Petal in same sp as last sl st. *Skip next dc. 1 sc in next ch-2 sp. *Working in front of the same ch-2 sp of 7th rnd,* Cluster in sp between 3-scfp and 5-dcfp groups of 6th rnd. 1 sc in same ch-2 sp as last sc.** Skip next dc. Petal in next ch-3 sp. Rep from * around, ending at **. Join. Fasten off. 12 petals and 12 clusters.

Tip from Mikey: Cluster Wedge - Special Stitches

Consists of two different types of clusters. The first cluster goes in and fills the space, the second cluster is wrapped around the first cluster so it is on its side.

9th rnd: Join A with sl st to tr of any petal. Ch 1. 1 sc in same sp as sl st. Skip next (dc, hdc, 2 sc). Small dc-cluster in top of next cluster. Tr-cluster around post of dc-cluster just made. *Skip next (2 sc, hdc, dc). 1 sc in next tr of next petal. Skip next (dc, hdc, 2 sc). Small dc-cluster in the top of next cluster. Tr-cluster around posts of dc-cluster just made. Rep from * around. Join. 12 cluster formations and 12 sc.

10th rnd: Ch 1. 1 sc in same sp as sl st. 7 dc in next ch-3 sp of Tr-cluster. *1 sc in next sc. 7 dc in next ch-3 sp or Tr-cluster. Rep from * around. Join. 84 dc and 12 sc.

Diagram I

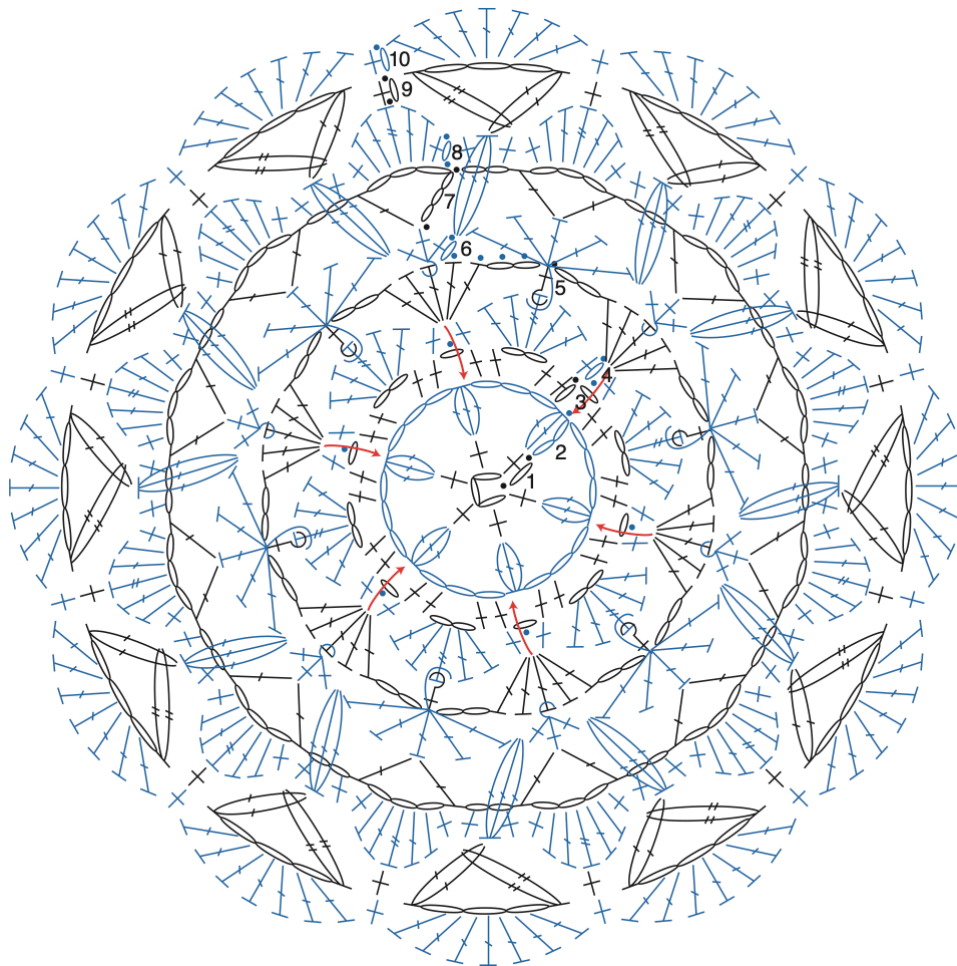

STITCH KEY

- = chain (ch)
- = slip stitch (sl st)
- † = single crochet (sc)
- ┆ = half double crochet (hdc)
- ┆ = double crochet (dc)
- ┆ = treble crochet (tr)
- ┆ = front post single crochet (scfp)
- ┆ = back post single crochet (scbp)
- ┆ = front post double crochet (dcfp)
- ⊖ = cluster
- ⊖ = double crochet cluster (dc-cluster)
- ⊖ = treble crochet cluster (tr-cluster)

See Diagram II on page 6.



Note: Ch 2 at beg of rnd **does not** count as st.

11th rnd: Sl st around back post of each of next 2 dc. Ch 2. 1 dcbp around same post as last sl st. Ch 1. (1 dcbp around post of next dc. Ch 1) 4 times. Skip next dc. 3 dcfp around post of next sc. *Ch 1. Skip next dc. (1 dcbp around post of next dc. Ch 1) 5 times. Skip next dc. 3 dcfp around post of next sc. Rep from * around. Ch 1. Join with sl st around post at back of first dc. 60 dcbp, 72 ch-1 sps and 36 dcfp.

12th rnd: Ch 2. 1 dcbp around same post as sl st. (1 dc in next ch-1 sp. 1 dcbp around post of next dc) 4 times. Skip next [ch-1 sp and dcfp (first dcfp of next 3-dcfp group)]. Puff st around front post of next dcfp. *Skip next (dcfp and ch-1 sp). (1 dcbp around post of next dc. 1 dc in next ch-1 sp) 4 times. 1 dcbp around post of next dc. Skip next [ch-1 sp and dc

(first dcfp of next 3-dcfp group)]. Puff st around front post of next dcfp. Rep from * around. Join with sl st around post at back of first dc. 60 dcbp, 48 dc and 12 puff sts.

13th rnd: Ch 2. 1 dcbp around same post as sl st. (Ch 1. Skip next dc. 1 dcbp around post of next dcbp) 4 times. *Yoh and draw up a loop around post of next dcfp of 11th rnd at front of work inserting hook from **right to left**. Yoh and draw through 2 loops on hook. Skip next puff st. Yoh and draw up a loop around post of next dcfp of 11th rnd at front of work inserting hook from **right to left**. Yoh and draw through 2 loops on hook. Yoh and draw through all 3 loops on hook- Dcfp2tog made. **Note:** Puff stitch in last round will naturally pop out between the posts.* * (1 dcbp around post of next dcbp. Ch 1. Skip next dc) 4 times. 1 dcbp around post of next dcbp. Dcfp2tog. Rep from * around. Join. 60 dcbp, 48 ch-1 sps, and 12 dcfp.

14th rnd: Ch 1. 1 sc in same sp as sl st. (*Working in front of next ch-1 sp*, 1 dcfp around post of next dc of 12th rnd. 1 sc in next dcbp) 4 times. 3 dcfp around post of next dc2tog. *1 sc in next dcbp. (*Working in front of next ch-1 sp*, 1 dcfp around post of next dc of 12th rnd. 1 sc in next dcbp) 4 times. 3 dcfp around post of next dc2tog. Rep from * around. Join. Fasten off. 60 sc, 48 dcfp and 36 dc.

15th rnd: Join A with standing sc to back post of any middle dcfp of 3-dcfp group (right above dcfp2tog). Ch 3. Skip next st. 1 scbp around post of next sc. Ch 3. (*Yoh and draw up a loop around post of next dcfp at front of work inserting hook from **right to left**. Yoh and draw through 2 loops on hook. Skip next sc*) 3 times. *Yoh and draw up a loop around post of next dcfp at front of work inserting hook from **right to left**. Yoh and draw through 2 loops on hook. Yoh and draw through all 5 loops on hook - Dcfp4tog made.* Ch 3. 1 scbp around post of next sc. Ch 3. *Skip next dcbp. 1 scbp in around post of next dcbp (middle st of 3-dcbp group). Ch 3. 1 scbp around post of next sc. Ch 3. Dcfp4tog. Ch 3.

1 scbp around post of next sc. Ch 3. Rep from * around. Join. 48 ch-3 sps, 36 scbp and 12 dc4tog.

16th rnd: Ch 1. 3 sc in each ch-3 sp around. Join. 144 sc.

17th rnd: Ch 1. 1 sc in each sc around. Join. 144 sc.

18th rnd: Beg popcorn in same sp as sl st. Ch 5. *Skip next 5 sc. Popcorn in next sc. Ch 5. Rep from * around. Join with sl st to top of first popcorn. Fasten off. 24 popcorns and 24 ch-5 sps.

Tip from Mikey: For next rnd, push ch-5 under dc so it traps it under the stitches. Jump over the popcorn stitches so they remain exposed in front.

19th rnd: Join A with sl st to first skipped sc of 17th rnd after popcorn. Ch 3 (counts as dc). Working over ch-5 sp into sc of 17th rnd, 1 dc in same sp as sl st. Working over ch-5 sp, 1 dc in each of next 4 sc of 17th rnd. 1 scfp around next popcorn. *Working over ch-5 sp into sc of 17th rnd, 2 dc in next sc. 1 dc in each of next 4 sc. 1 scfp around next popcorn. Rep from * around. Join. Fasten off. 144 dc and 24 scfp. 168 sts total.

Diagram II

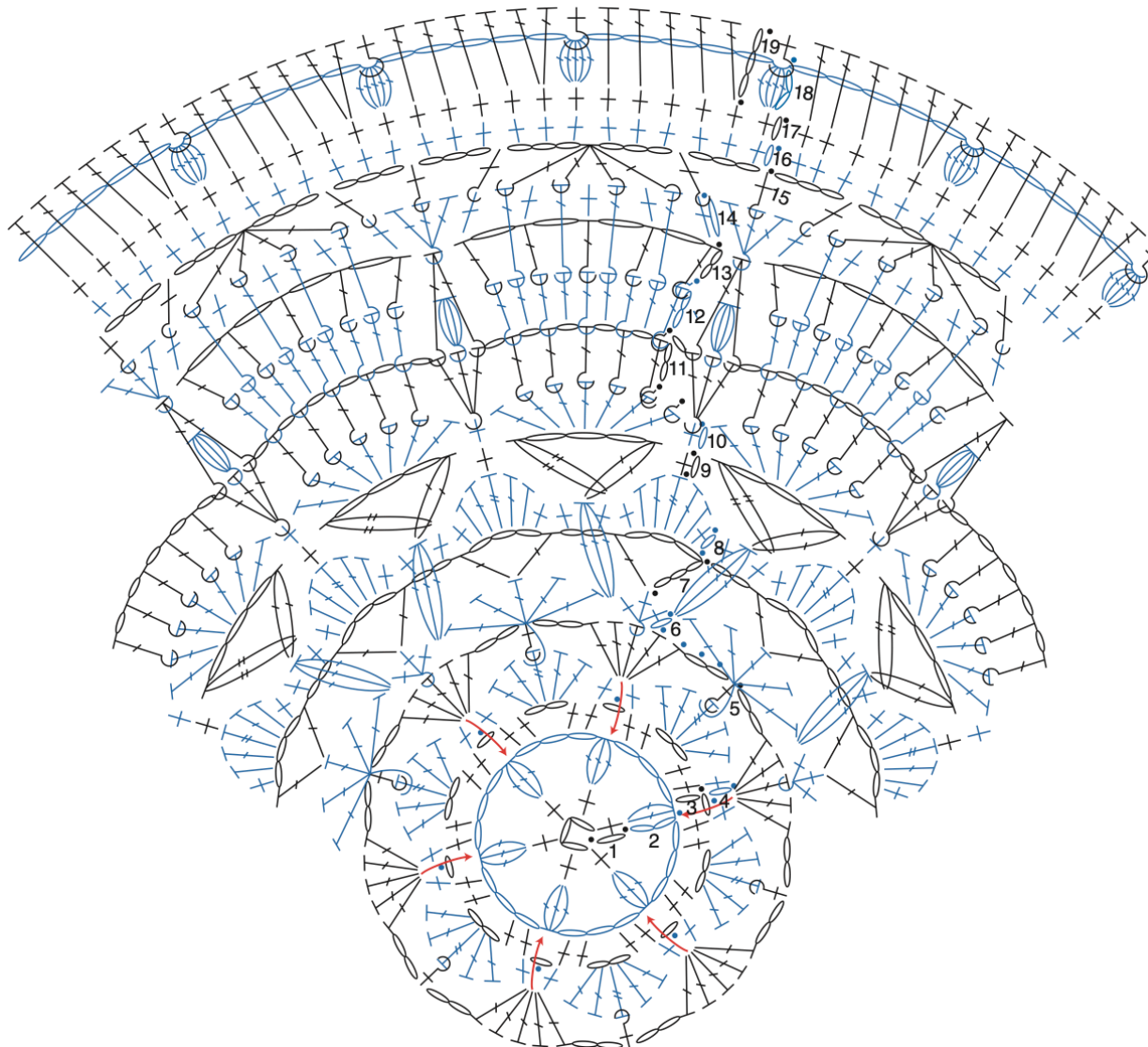

STITCH KEY

- = chain (ch)
- = slip stitch (sl st)
- ⊙ = slip stitch around back post (sl st)
- † = single crochet (sc)
- ┆ = half double crochet (hdc)
- ┆ = double crochet (dc)
- ┆ = treble crochet (tr)
- ┆ = front post single crochet (scfp)
- ┆ = back post single crochet (scbp)
- ┆ = front post double crochet (dcfp)
- ┆ = back post double crochet (dcbp)
- ⊕ = cluster
- ⊕ = double crochet cluster (dc-cluster)
- ⊕ = treble crochet cluster (tr-cluster)
- ⊕ = puff stitch (puff st) around front post
- ┆ = front post double crochet 4 together (dcfp4tog)
- ⊕ = popcorn



Transition to Square:

See Diagram III on page 8.

Note: Ch 3 at beg of rnd counts as dc.

20th rnd: Join A with sl st to scfp on top of any popcorn. Ch 3. (1 dc. Ch 2. 2 dc) in same st as sl st. *1 dc in each of next 5 dc. 1 hdc in each of next 5 sts. 1 sc in each of next 21 sts. 1 hdc in each of next 5 sts. 1 dc in each of next 5 sts.** (2 dc. Ch 2. 2 dc) in next st. Rep from * twice more, then from * to ** once. Join. 45 sts between corner ch-2 sps.

21st rnd: Sl st to next ch-2 sp. Ch 3. (1 dc. Ch 2. 2 dc) in same sp as last sl st. *(1 dcfp around next st. 1 dcbp around next st) 6 times. 1 sc in each of next 21 sc. (1 dcbp around next st. 1 dcfp around next st) 6 times.** (2 dc. Ch 2. 2 dc) in next ch-2 sp. Rep from * twice more, then from * to ** once. Join. 49 sts between corner ch-2 sps.

22nd rnd: Sl st to next ch-2 sp. Ch 1. (1 sc. Ch 2. 1 sc) in same sp as last sl st. *1 sc in each st to next ch-2 sp.** (1 sc. Ch 2. 1 sc) in next ch-2 sp. Rep from * twice more, then from * to ** once. Join. 51 sts.

Tip from Mikey: When skipping first st out, first dc will be 3rd st from the corner. When getting to the end of a side, automatically skip last stitch and go right into the corner.









23rd rnd: Sl st to next ch-2 sp. Ch 3. (1 dc. Ch 2. 2 dc) in same sp as last sl st (counts as 2 dc, ch 2, 2 dc). *1 trfp around post of first dc after ch-2 sp 2 rows below. Skip first 2 sc of 22nd rnd after ch-2 sp. 1 dc in next sc. (Skip next st 2 rows below. 1 trfp around post of next st 2 rows below. Skip next sc of 22nd rnd. 1 dc in next sc) 6 times. 1 hdc in each of next 6 sts. 1 sc in each of next 9 sts. 1 hdc in each of next

6 sts. (1 dc in next st. 1 trfp around post of corresponding st 2 rows below. Skip next sc behind st just made) 7 times. Skip last sc before corner ch-2 sp.** (2 dc. Ch 2. 2 dc) in next corner. Rep from * twice more, then from * to ** once. Join. 53 sts between corner ch-2 sps.

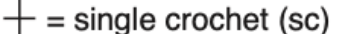
24th rnd: Sl st to next ch-2 sp. Ch 3. (1 dc. Ch 2. 2 dc) in same sp as last sl st. *1 dc in each of next 5 sts. 1 hdc in each 31 ext 6 sts. 1 sc in each of next ~~23~~ sts. 1 hdc in each of next 6 sts. 1 dc in each of next 5 sts.** (2 dc. Ch 2. 2 dc) in next corner ch-2 sp. Rep from * twice more, then * to ** once. Join. 57 sts between corner ch-2 sps.

25th rnd: Sl st to next ch-2 sp. Ch 3. (1 dc. Ch 2. 2 dc) in same sp as last sl st. *1 dc in each st to next ch-2 sp.** (2 dc. Ch 2. 2 dc) in next corner ch-2 sp. Rep from * twice more, then from * to ** once. Join. Fasten off. 61 sts between corner ch-2 sps.

STITCH KEY

-  = chain (ch)
-  = slip stitch (sl st)
-  = single crochet (sc)
-  = half double crochet (hdc)
-  = double crochet (dc)
-  = front post double crochet (dcfp)
-  = back post double crochet (dcbp)
-  = front post treble crochet (trfp)

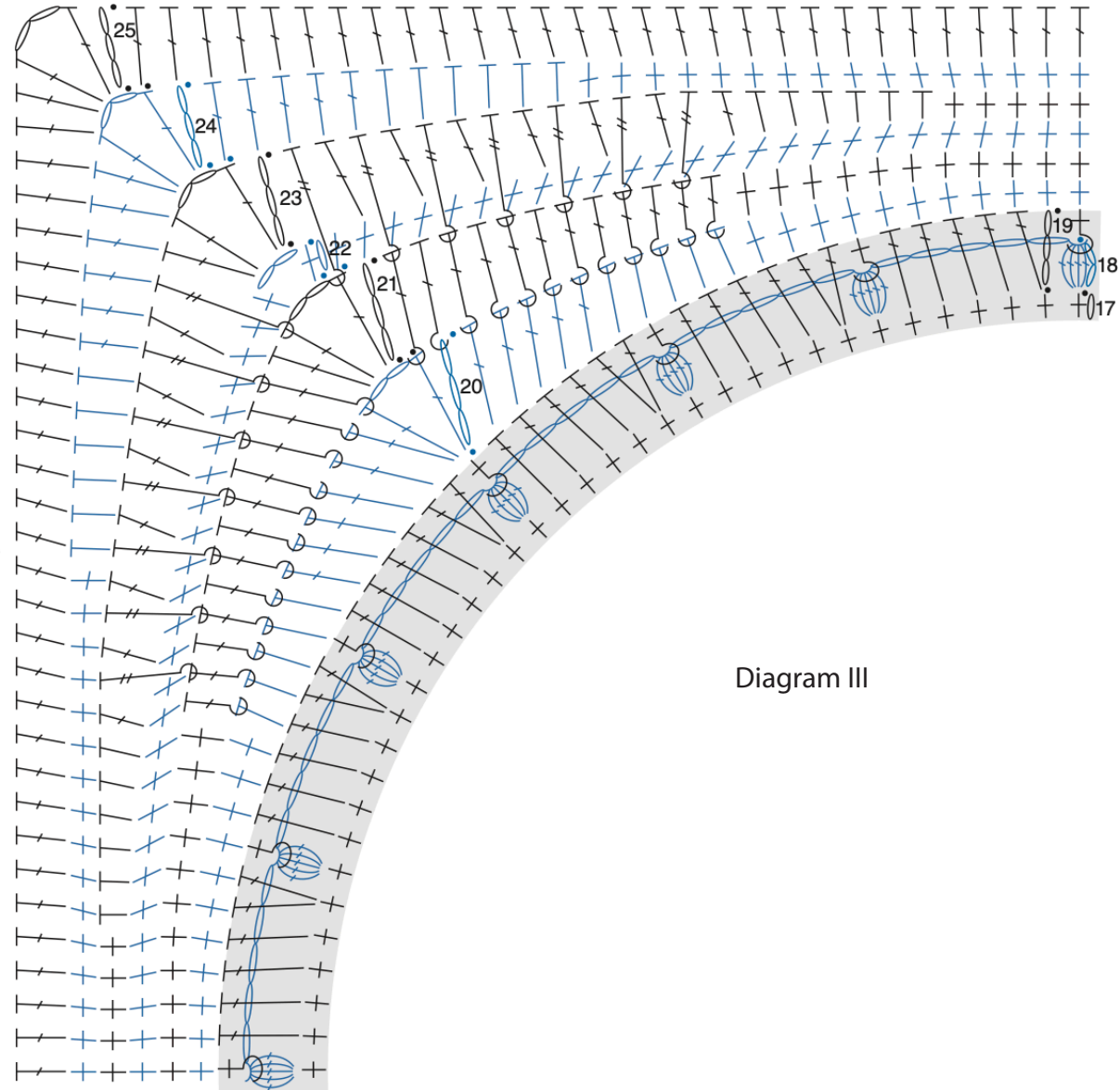

Diagram III

Diagonal Spikes:



Notes: - Ch 2 at beg of rnd **does not** count as st.

- Ch 3 at beg of rnd counts as dc.

26th rnd: Join B with sl st to any corner ch-2 sp. Ch 2. (1 hdc. Ch 2. 1 hdc) in same sp as sl st. *1 dcbp around post of each dc to next corner ch-2 sp.** (1 hdc. Ch 2. 1 hdc) in next corner ch-2 sp. Rep from * twice more, then from * to ** once. Join with sl st to top of first hdc. 63 sts between corner ch-2 sps.

27th rnd: Sl st to next corner ch-2 sp. Ch 3. (1 dc. Ch 2. 2 dc) in same sp as last sl st. *(Skip next st. 1 dc in each of next 2 sts. 1 tr in skipped stitch, working overx3 last 2 dc just made) across to next corner ch-2 sp.** (2 dc. Ch 2. 2 dc) in next corner ch-2 sp. Rep from * twice

more, then from * to ** once. Join. 21 groups of 3-sts, total of 67 sts between corner ch-2 sps.

28th rnd: Sl st to next ch-2 sp. Ch 1. (1 sc. Ch 2. 1 sc) in same sp as last sl st. *1 sc in each st to next ch-2 sp.** (1 sc. Ch 2. 1 sc) in next ch-2 sp. Rep from * twice more, then from * to ** once. Join. 69 sc between corner ch-2 sps.

29th to 34th rnds: As 27th and 28th rnds 3 times more. 87 sts between corner ch-2 sps at end of last rnd.

35th rnd: As 27th rnd. 91 sts between corner ch-2 sps.

36th rnd: Sl st to next corner ch-2 sp. Ch 3. (1 dc. Ch 2. 2 dc) in same sp as sl st. *1 dc in each st to next ch-2 sp.** (2 dc. Ch 2. 2 dc) in next corner ch-2 sp. Rep from * twice more, then from * to ** once. Join. 95 sts between corner ch-2 sps.

37th rnd: A 26th rnd. Fasten off. 97 sts between corner ch-2 sps.

Diagram IV

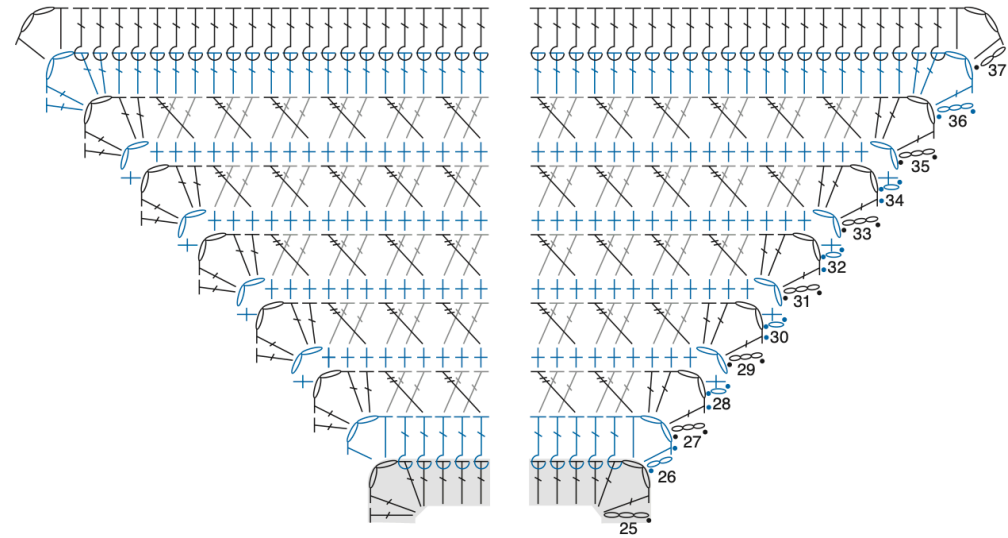

STITCH KEY

- = chain (ch)
- = slip stitch (sl st)
- ⊕ = single crochet (sc)
- ⊥ = half double crochet (hdc)
- ⌋ = double crochet (dc)
- ⌋⌋ = treble crochet (tr)
- ⌋⌋⌋ = back post double crochet (dcbp)

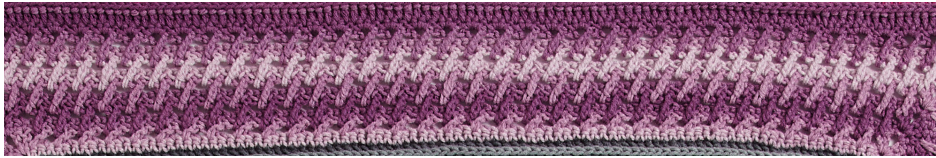

Cross Ripples:

See Diagram V on page 11.

Note: Turn work with WS facing to you to begin this section. All rnds are worked with WS facing you.

38th rnd: (WS). Join C with sl st to any corner ch-2 sp. Ch 1. (1 sc. Ch 2. 1 sc) in same sp as sl st. *1 sc in each st to next corner ch-2 sp.** (1 sc. Ch 2. 1 sc) in next ch-2 sp. Rep from * twice more, then from * to ** once. Join. 99 sc between corner ch-2 sps.

39th rnd: Sl st to next corner ch-2 sp. Ch 3. (1 dc. Ch 2. 2 dc) in same sp as last sl st. *(Skip next 2 sc. 1 dc in next sc. Ch 1. Working at front of work (WS), 1 dc in first skipped st) across to next corner ch-2 sp.** (2 dc. Ch 2. 2 dc) in next corner ch-2 sp. Rep from * twice more, then from * to ** once. Join. 103 sts with 33 criss-cross groups between corner ch-2 sps.

40th rnd: Sl st to next corner ch-2 sp. Ch 1. (1 sc. Ch 2. 1 sc) in same sp as last sl st. *1 sc in each of first 2 dc. (3 sc in next ch-1 sp. Skip next 2 dc) to last 2 dc before corner ch-2 sp. 1 sc in each of last 2 dc before corner ch-2 sp.** (1 sc. Ch 2. 1 sc) in next ch-2 sp. Rep from * twice more, then from * to ** once. Join. 105 sc between corner ch-2 sps.

41st rnd: Sl st to next corner ch-2 sp. Ch 3. (1 dc. Ch 2. 2 dc) in last sl st. *Skip next 2 sc. 1 dc in next sc. Ch 1. Working at front of work (WS), 1 dc in first skipped st. (Skip next 2 sc. 1 dc in next sc. Ch 1. 1 trbp around post of dc 2 rnds below under skipped sc) across to next corner ch-2 sp.** (2 dc. Ch 2. 2 dc) in next corner ch-2 sp.* Rep from * twice more, then from * to ** once. Join. 109 sts with 35 criss-cross groups between corner ch-2 sps.

42nd to 47th rnds: As 40th and 41st rnds 3 times more. 127 sts between corner ch-2 sps at end of last rnd.

48th rnd: As 40th rnd. 129 sts between corner ch-2 sps.



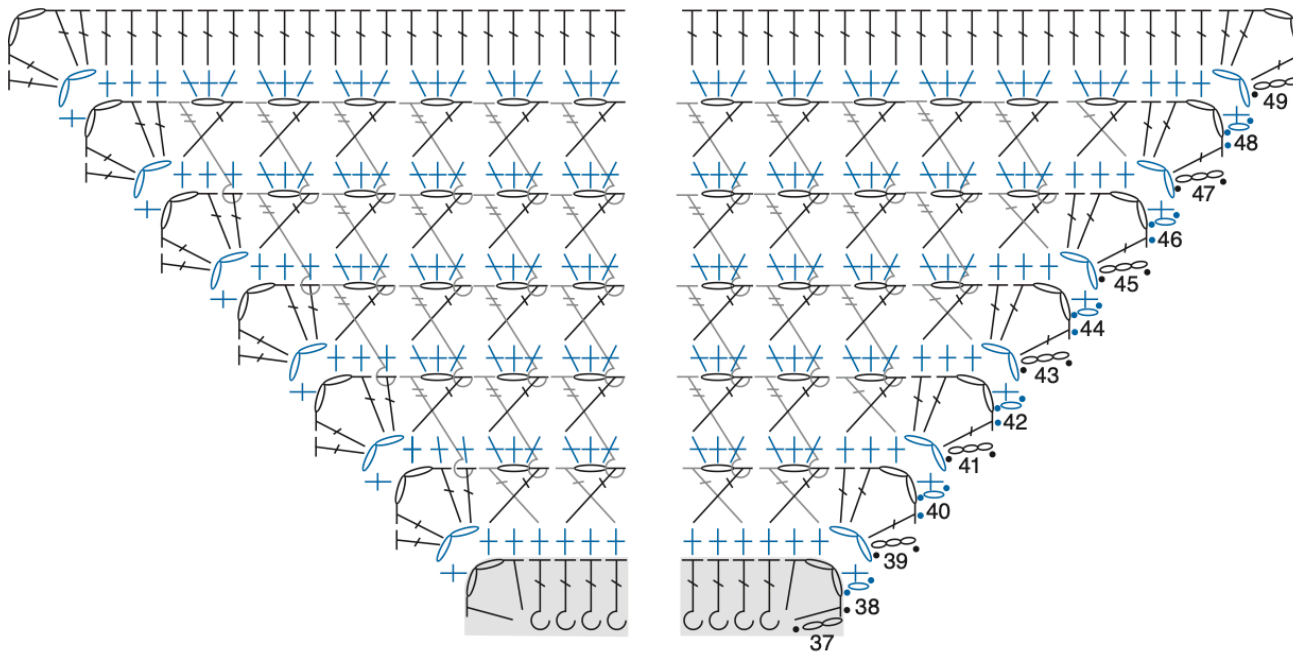

Turn work to RS for next following rnds.

49th rnd: (RS). Sl st to next ch-2 sp. Ch 3. (1 dc. Ch 2. 2 dc) in same sp as last sl st. *1 dc in each st to next ch-2 sp.** (2 dc. Ch 2. 2 dc) in next corner ch-2 sp. Rep from * twice more, then from * to ** once. Join. Fasten off. 133 sts between corner ch-2 sps.

Diagram V



STITCH KEY

-  = chain (ch)
-  = slip stitch (sl st)
-  = single crochet (sc)
-  = double crochet (dc)
-  = back post treble crochet (trbp)

Alpine Ribs:



Notes:

- Ch 2 at beg of rnd **does not** count as st.
- Ch 3 at beg of rnd counts as dc.

Tip from Mikey: Changing yarn at the same corner throughout this segment will have 1 color always looking out of place. When starting a new color, jump to a different corner to start so it appears to blend better.

50th rnd: Join B with sl st to any corner ch-2 sp. Ch 2. (1 hdc. Ch 2. 1 hdc) in same sp as sl st. *1 dcbp around post of each dc to next corner ch-2 sp. ** (1 hdc. Ch 2. 1 hdc) in next corner ch-2 sp. Rep from * twice more, then from * to ** once. Join with sl st to top of first hdc. Fasten off. 135 sts between corner ch-2 sps.

51st rnd: Join A with sl st to any corner ch-2 sp. Ch 3. (1 dc. Ch 2. 2 dc) in same sp as sl st. *1 trfp around post of next st. (1 dc in next st. 1 trfp around post of next st) across to next corner ch-2 sp. (2 dc. Ch 2. 2 dc) in next corner ch-2 sp. Rep from * twice more, then from * to ** once. Join. Fasten off. 139 sts with 68 trfp and 71 dc between corner ch-2 sps.

52nd rnd: With B, as 51st rnd. 143 sts between corner ch-2 sps.

53rd rnd: With C, as 51st rnd. 147 sts between corner ch-2 sps.

54th rnd: With B, as 51st rnd. 151 sts between corner ch-2 sps.

55th rnd: With A, as 51st rnd. 155 sts between corner ch-2 sps.

56th rnd: Sl st to next ch-2 sp. Ch 3. (1 dc. Ch 2. 2 dc) in same sp as last sl st. *1 dc in each st to next ch-2 sp.** (2 dc. Ch 2. 2 dc) in next corner ch-2 sp. Rep from * twice more, then from * to ** once. Join. Fasten off. 159 sts between corner ch-2 sps.

Diagram VI

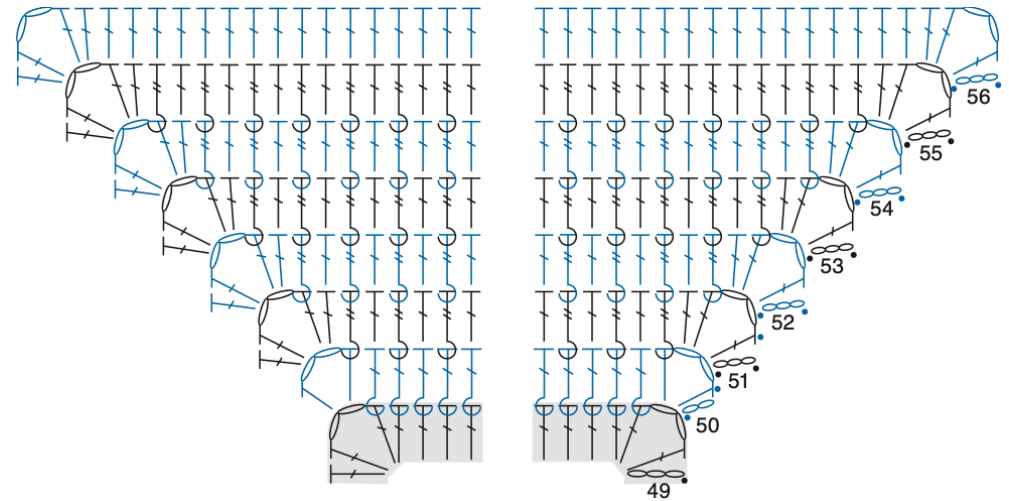

STITCH KEY

- = chain (ch)
- = slip stitch (sl st)
- ┆ = half double crochet (hdc)
- ┆ = double crochet (dc)
- ┆ = front post treble crochet (trfp)

Back Loops Border:



57th rnd: Join B with sl st to any corner ch-2 sp. Ch 2. (1 hdc. Ch 2. 1 hdc) in same sp as sl st. *1 dcbp around post of each dc to next corner ch-2 sp. ** (1 hdc. Ch 2. 1 hdc) in next corner ch-2 sp. Rep from * twice more, then from * to ** once. Join with sl st to top of first hdc. 161 sts between corner ch-2 sps.

58th rnd: Sl st to next ch-2 sp. Ch 3. (1 dc. Ch 2. 2 dc) in same sp as last sl st. *Working in back loops only, 1 dc in each st to next ch-2 sp.** (2 dc. Ch 2. 2 dc) in next corner ch-2 sp. Rep from * twice more, then from * to ** once. Join. Fasten off. 165 sts between corner ch-2 sps.

59th rnd: Sl st to next corner ch-2 sp. Ch 2 (doesn't count as st). (1 hdc. Ch 2. 1 hdc) in same sp as last sl st. Working in back loops only, 1 hdc in each st to next corner ch-2 sp.** (1 hdc. Ch 2. 1 hdc) in next

corner ch-2 sp. Rep from * twice more, then from * to ** once. Join. Fasten off. 167 sts between corner ch-2 sps.

Version 1: with A, work last 4 rnds.
Version 2: With C, work last 4 rnds.

60th rnd: Join A for Version 1 or C for Version 2, with sl st to any corner ch-2 sp. Ch 1. (1 sc. Ch 2. 1 sc) in same sp as sl st. Working in back loops only, 1 sc in each st to next corner ch-2 sp.** (1 sc. Ch 2. 1 sc) in next corner ch-2 sp. Rep from * twice more, then from * to ** once. Join. 169 sts between corner ch-2 sps.

61st rnd: As 59th rnd. 171 sts between corner ch-2 sps.

62nd rnd: Sl st to next ch-2 sp. Ch 3. (1 dc. Ch 2. 2 dc*) in same sp as last sl st. *Working in back loops only, 1 dc in each st to next ch-2 sp.** (2 dc. Ch 2. 2 dc) in next corner ch-2 sp. Rep from * twice more, then from * to ** once. Join. Fasten off. 175 sts between corner ch-2 sps.

Tip from Mikey: You may be playing yarn chicken with the last round using A or C. Switch to a different color if you feel you won't have enough to go around. We are left with approx 3 feet of yarn which is really close.

63rd rnd: Sl st to next corner ch-2 sp. Ch 1. 3 sc in same sp as last sl st. 1 sc in each st to next corner ch-2 sp.** 3 sc in next corner ch-2 sp. Rep from * twice more, then from * to ** once. Join. Fasten off.

STITCH KEY

- = chain (ch)
- = slip stitch (sl st)
- † = single crochet (sc)
- ⌋ = half double crochet (hdc)
- ⌋ = double crochet (dc)
- ⌋ = back post double crochet (dcbp)
- ⌋ = worked in back loop only

Diagram VII

