



CROCHET | SKILL LEVEL: **EASY**

ABBREVIATIONS

Approx =

Approximately

Beg = Begin(ning)(s)

Ch = Chain(s)

Hbhd = Herringbone half double crochet –

Yoh and insert hook into designated stitch. Draw through stitch

and first loop on hook. Yoh and draw

through both loops.

Hbhd2tog =

Herringbone half

double crochet

2 together - (Yoh and insert hook into next stitch. Draw through

stitch and first loop on hook) twice. Yoh

and draw through all loops.

Pat = Pattern

PM = Place marker

Rem = Remain(ing)(s)

Rep = Repeat

Rnd(s) = Round(s)

RS = Right side

Sc = Single crochet

Sl st = Slip stitch

Sp(s) = Space(s)

St(s) = Stitch(es)

WS = Wrong side

Yoh = Yarn over hook

SIZES

To fit chest measurement

4 yrs 24" [61 cm]

6 yrs 26" [66 cm]

8 yrs 28" [71 cm]

Finished chest

4 yrs 28" [71 cm]

6 yrs 31" [78.5 cm]

8 yrs 34" [86.5 cm]

GAUGE

14 hbhd and 12 rows = 4" [10 cm].

INSTRUCTIONS

Notes:

- Garment is worked in one piece from neck edge down.
- Ch 2 at beg of row **does not** count as st.

Beg at neck edge, ch 32.

1st row: (RS). 1 hbhd in 3rd ch from hook. 1 hbhd in each ch to end of chain. Turn. 30 sts.

2nd row: Ch 2. (1 hbhd in next st. 2 hbhd in next st) twice. 1 hbhd in next st. PM on last st. 2 hbhd in each of next 2 sts. 1 hbhd in

MATERIALS

Red Heart® Roll With It Sparkle™ (5.29 oz/150 g; 561 yds/513 m)

Sizes	4	6	8	yrs
Pixie (9710)	2	2	3	balls

Size U.S. 7 (4.5 mm) crochet hook **or size needed to obtain gauge.**
Tapestry needle. 2 stitch markers.

next st. PM on last st. 2 hbhdc in next st. 1 hbhdc in each of next 12 sts. 2 hbhdc in next st. 1 hbhdc in next st. PM on last st. 2 hbhdc in each of next 2 sts. 1 hbhdc in next st. PM on last st. (2 hbhdc in next st. 1 hbhdc in next st) twice. Turn. 40 sts.

3rd row: Ch 2. 1 hbhdc in first st. 2 hbhdc in next st. (1 hbhdc in each st to 1 st before marked st. 2 hbhdc in next st. 1 hbhdc in next st. PM on last st. 2 hbhdc in next st) 4 times. 1 hbhdc in each st until last 2 sts. 2 hbhdc in next st. 1 hbhdc in last st. Turn. 50 sts. Rep 3rd row **13 (15-17)** times more. **180 (200-220)** sts.

Next row: Ch 2. 1 hbhdc in first st. 2 hbhdc in next st. 1 hbhdc in each st to last 2 sts. 2 hbhdc in next st. 1 hbhdc in last st. Turn. **182 (202-222)** sts.

Divide Sleeves and Body

1st row: Ch 2. 1 hbhdc in first st. 2 hbhdc in next st. [1 hbhdc in each st to marked st. Ch 4. Skip next **34 (38-42)** sts] twice. 1 hbhdc in each st to last 2 sts. 2 hbhdc in next st. 1 hbhdc in last st. Turn. **124 (136-148)** st rem for Body.

2nd row: Ch 2. 1 hbhdc in first st. 2 hbhdc in next st. 1 hbhdc in each st and ch to last 2 sts. 2 hbhdc in next st. 1 hbhdc in last st. Turn. **126 (138-150)** sts.

3rd row: Ch 2. 1 hbhdc in first st. 2 hbhdc in next st. 1 hbhdc in each st to last 2 sts. 2 hbhdc in next st. 1 hbhdc in last st. Turn. **128 (140-152)** sts. Rep 3rd row **9 (11-13)** times more. **146 (162-178)** sts.

Next row: Ch 2. 1 hbhdc in each st across. Turn. Rep last row **1 (2-3)** time(s) more. Fasten off.

Picot Neck Edging

With **WS** facing, join yarn with sl st to bottom corner of Left Front. Work 1 row of sc evenly up Left Front, across back neck and down Right Front, ending with an odd number of sts. Turn.

Next row: (RS). Ch 1. 1 sc in first sc. *Ch 3. 1 sc in 2nd and 3rd ch from hook. Skip next sc. 1 sc in next sc. Rep from * to end of row. Fasten off.

Sleeves

Notes:

- To match stripe pat of yarn, beg each Sleeve at same point in color transition.
- Turn at end of each rnd to maintain same pat as Body.

1st rnd: (RS). Join yarn with sl st in rem loop of 3rd ch of ch-4 armhole. Ch 2. 1 hbhdc in same sp as sl st. 1 hbhdc in next ch. 1 hbhdc in each st around. 1 hbhdc in each of next 2 ch. Join with sl st to first st. Turn. **38 (42-46)** sts.

2nd rnd: Ch 2. 1 hbhdc in each st around. Join. Turn. Rep 2nd rnd twice more.

Begin Sleeve Shaping: 1st rnd:

Ch 2. Hbhdc2tog. 1 hbhdc in each st to last 2 sts. Hbhdc2tog. Join. Turn. **36 (40-44)** sts.

2nd to 5th rnds: Ch 2. 1 hbhdc in each st around. Join. Turn. Rep last 5 rnds **4 (5-6)** times more. **28 (30-32)** sts.

Rep 2nd rnd until Sleeve measures **10 (11½-13)" [25.5 (29-33) cm]**.

Picot Border

Next rnd: Ch 1. 1 sc in same sp as last sl st. *Ch 3. 1 sc in 2nd and 3rd ch from hook. Skip next st. 1 sc in next st. Rep from * around. Join with sl st to first sc. Fasten off.

Waistband/Tie

Ch 7.

1st row: Ch 1. 1 sc in 2nd ch from hook. 1 sc in each ch to end of chain. Turn. 6 sc.

2nd row: Ch 1. *Working in back loops only*, 1 sc in each sc to end of row. Turn.

Rep 2nd row until Waistband/Tie measures **76 (82-88)" [193 (208.5-223.5) cm]**, when slightly stretched. Fasten off.

Place a st marker 10" [25.5 cm] from right edge of Waistband/Tie. Place 2nd st marker **42 (46½-51)" [106.5 (118-129.5) cm]** from first marker. (See diagram on page 3). Sew lower edge of Cardigan Body to Waistband/Tie, between st markers.

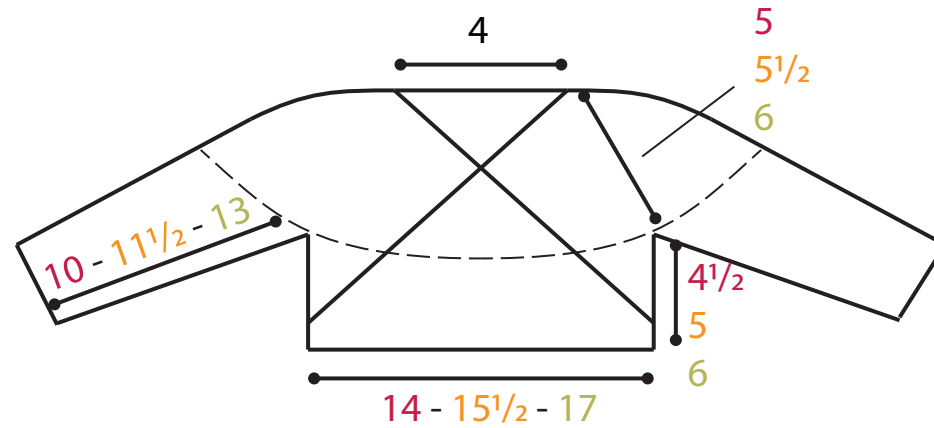

Front

Back

