



SOFT SHADES LAYETTE

SIZES

Chest measurement

3 mos	15 ins	[38 cm]
6 mos	16 ins	[41 cm]
12 mos	18 ins	[45 cm]
18 mos	20 ins	[51 cm]

Finished chest

3 mos	20 ins	[51 cm]
6 mos	21 ins	[53.5 cm]
12 mos	24½ ins	[62 cm]
18 mos	25½ ins	[65 cm]

TENSION

27 sts and 42 rows = 4 ins [10 cm] with larger needles in pat.

MATERIALS

Patons Astra (50 g/1.75 oz)
Size 3 6 12 18 mos

PULLOVER AND PANTS

Main color (MC) (Ombre)
 6 6 7 7 balls

Contrast A (Blue)
 1 1 2 2 balls

BOOTIES 3/6 12/18 mos

Main color (MC) (Ombre)
 1 1 ball

Small quantity of **Contrast A** (Blue).

Sizes 3.25 mm (U.S 3) and 3.75 mm (U.S. 5) knitting needles **or size needed to obtain tension.** Length of ¾ in [2 cm] wide elastic to fit waist measurement for Pants.

INSTRUCTIONS

The instructions are written for smallest size. If changes are necessary for larger sizes the instructions will be written thus ().

BACK

With A and smaller needles cast on 63 (68-78-83**) sts.

Work 5 rows garter st (knit every row), noting that first row is WS, and inc 4 sts evenly across last row. 67 (**72-82-87**) sts.

Change to MC, larger needles and proceed as follows:

1st row: (RS). K3. *Sl1P. K4. Rep from * to last 4 sts. Sl1P. K3.

2nd row: Purl.

3rd and 4th rows: As 1st and 2nd rows once more.

5th row: As 1st row.

6th row: K3. *P1. K4. Rep from * to last 4 sts. P1. K3.

These 6 rows form check pat.

Cont working in check pat until work from beg measures 3 (**3¾-4½-6½**) ins [7.5 (**9.5-11.5-16.5**) cm], ending with RS facing for next row.

Armhole shaping: Cast off 5 sts beg next 2 rows. 57 (**62-72-77**) sts.**

Cont working in check pat until Back from beg measures 7½ (**8½-9¾-12**) ins [19 (**21.5-25-30.5**) cm], ending with RS facing for next row.

Shape Shoulder Flaps: Next row:

Place marker. Pat across 17 (**18-22-24**) sts. K2tog. **Turn.** 18 (**19-23-25**) sts. Leave rem sts on a spare needle.

Next row: Work even in pat.

Next row: Pat across 16 (**17-21-23**) sts. K2tog. 17 (**18-22-24**) sts.

Next row: Work even in pat.

Keeping cont of pat, dec 1 st at end of next and every alt row until 1 st rem. Fasten off.

With RS of work facing, slip next 19 (**22-24-25**) sts from spare needle onto a st holder. Join yarn to rem sts. Sl1. K1. pssso. Pat to end of row. Place marker. 18 (**19-23-25**) sts.

Next row: Work even in pat.

Next row: Sl1. K1. pssso. Pat to end of row.

Next row: Work even in pat.

Keeping cont of pat, dec 1 st at beg of next and every alt row until 1 st rem. Fasten off.



ABBREVIATIONS: www.patonsyarns.com/glossary

FRONT

Work from ** to ** as given for Back.

Cont working in check pat until Front from beg measures 6½ (7½-8¾-11) ins [16.5 (19-22-28) cm] ending with RS facing for next row.

Neck shaping: Next row: Pat across 20 (24-28-28) sts (neck edge). **Turn.** Leave rem sts on a spare needle.

Next row: Cast off 5 (6-7-7) sts. Pat to end of row.

Next row: Work even in pat.

Rep last 2 rows until there are 5 (6-7-7) sts. Cast off.

With RS of work facing slip next 17 (14-16-21) sts from spare needle onto a st holder. Join yarn to rem sts and pat to end of row.

Next row: (WS). Work even in pat.

Next row: Cast off 5 (6-7-7) sts. Pat to end of row.

Rep last 2 rows until there are 5 (6-7-7) sts. Cast off.

SLEEVES

With A and smaller needles cast on 34 (36-38-40) sts.

Work 5 rows garter st noting that first row is WS and inc 9 sts evenly across last row. 43 (45-47-49) sts.

Change to MC, larger needles and proceed as follows:

1st row: (RS). K1 (2-3-4). *Sl1P. K4. Rep from * to last 2 (3-4-5) sts. Sl1P. K1 (2-3-4).

2nd row: Purl.

3rd and 4th rows: As 1st and 2nd rows once more.

5th row: Inc 1 st in first st. K0 (1-2-3). *Sl1P. K4. Rep from * to last 2 (3-4-5) sts. Sl1P. K0 (1-2-3). Inc 1 st in last st. 45 (47-49-51) sts.

6th row: K2 (3-4-0). *Sl1P. K4. Rep from * to last 3 (4-0-1) st(s). (Sl1P) 1 (1-0-1) time. K2 (3-0-0). Cont in check pat, as placed in last 6 rows, inc 1 st each end of needle on every following 4th row from previous inc to 63 (65-71-69) sts, taking inc sts into check pat.

18 mos only: Inc 1 st each end of needle on every following 6th row from previous inc to 75 sts.

All sizes: Cont even in pat until Sleeve from beg measures 5½ (6¼-7-8½) ins [14 (16-18-21.5) cm] ending with RS facing for next row. Place a marker at each end of last row. Cont even in pat for 8 rows. Cast off.

FINISHING

Pin garment pieces to measurements. Cover with damp cloth and leave to dry.

Back and shoulder flap edge: With RS of work facing, A and smaller needles, pick up and knit 30 (32-35-38) sts down left back shoulder flap from fasten off point to back neck edge. Knit across 19 (22-24-25) sts from back st holder dec 2 sts evenly across. Pick up and knit 30 (32-35-38) sts up right back shoulder flap to fasten off point. 77 (84-92-99) sts.

Work 4 rows in garter st. Cast off knitways (WS).

Front Neckband: With right side of work facing, A and smaller needles, pick up and knit 20 (25-30-30) sts up left front neck edge. Knit across 17 (14-16-21) sts from Front st holder. Pick up and knit 20 (25-30-30) sts up right front neck edge. 57 (64-76-81) sts. Knit 4 rows (garter st). Cast off knitways (WS).

Fold shoulder flaps along marked row and sew in position to front along armhole edge.

Sew in Sleeves placing rows above markers along cast off sts at armholes to form square armholes. Sew side and sleeve seams.

PANTS

RIGHT LEG (beg at waist)

**With smaller needles and MC, cast on 71 (75-79-83) sts.

1st row: (RS). K1. *P1. K1. Rep from * to end of row.

2nd row: P1. *K1. P1. Rep from * to end of row.

Rep these 2 rows (K1. P1) ribbing for 2¼ ins [5.5 cm] ending on a 2nd row and inc 1 (2-3-4) st(s) evenly across last row. 72 (77-82-87) sts.**

Proceed in check pat as given for Back of Pullover, shaping back as follows:

Next 2 rows: Pat across 17 sts. **Turn.** Sl1P. Pat to end of row.

Next 2 rows: Pat across 24 sts. **Turn.** Sl1P. Pat to end of row.

Next 2 rows: Pat across 31 sts. **Turn.** Sl1P. Pat to end of row.

Next 2 rows: Pat across 38 sts.

Turn. Sl1P. Pat to end of row.

Next 2 rows: Pat across 45 sts.

Turn. Sl1P. Pat to end of row.

Note: To avoid a hole when knitting a slipped st, pick up the st below the slipped st and slip it onto left hand needle. Knit this st tog with the slipped st above.

Next row: (RS). Pat across all sts.

***Cont in check pat until work at centre front measures 8 (8¼-8½-9¼) ins [20.5 (21-21.5-23.5) cm] ending with RS facing for next row.

Shape crotch: Inc 1 st each end of next and following 0 (0-1-1) alt row. Cast on 2 sts beg next 2 rows. 78 (83-90-95) sts.

Work 2 rows even in pat.

Shape inseam: Dec 1 st each end of needle on next and following 4th row. 74 (79-86-91) sts. Dec 1 st each end of needle on following 6th rows until there are 54 (59-62-65) sts.

Cont even in pat until work from last cast on at crotch measures 6¾ (7¼-8-9) ins [17 (18.5-20.5-23) cm] ending with RS facing for next row.

Next row: With A, knit, dec 11 sts evenly across. 43 (48-51-54) sts. Break MC.

With A and smaller needles, work 4 rows in garter st. Cast off knitwise (WS). ***

LEFT LEG (beg at waist)

Work from ** to ** as given for Right Leg.

Proceed as follows:

Next row: (RS). Work as given for 1st row of check pat Back of Pullover.

Shape back: Next 2 rows: Pat across 17 sts. **Turn.** Sl1K. Pat to end of row.

Next 2 rows: Pat across 24 sts.

Turn. Sl1K. Pat to end of row.

Next 2 rows: Pat across 31 sts.

Turn. Sl1K. Pat to end of row.

Next 2 rows: Pat across 38 sts.

Turn. Sl1K. Pat to end of row.

Next 2 rows: Pat across 45 sts.

Turn. Sl1K. Pat to end of row.

Note: To avoid a hole when purling a slipped st, pick up the st below the slipped st and slip it onto left hand needle. Purl this st tog with the slipped st above.

Next row: (WS). Pat across all sts. Work from *** to *** as given for Right Leg.

FINISHING: Pin garment pieces to measurements. Cover with a damp cloth leaving to dry.

Sew shoulder seams.

Sew inseams. Sew crotch seam.

Fold waistband in half to wrong side and sew loosely in position leaving an opening to insert elastic.

Sew ends of elastic tog securely.

Sew opening of waistband closed.

BOOTIES

With MC and larger needles, cast on 38 (48) sts.

1st row: (WS). Knit.

2nd row: Inc 1 st in first st. K17 (22).

(Inc 1 st in next st) twice. K16 (21).

Inc 1 st in next st. K1. 42 (52) sts.

3rd row: Knit.

4th row: Inc 1 st in first st. K19

(24). (Inc 1 st in next st) twice. K18

(23). Inc 1 st in next st. K1.

46 (56) sts.

5th row: Knit.

Cont inc 4 sts on next and following alt row, as before, until there are 54 (64) sts.

Next row: Knit.

Shape Instep: 1st row: K20 (25). Sl1K. K1. pssso. P10 (instep). K2tog. K20 (25). 52 (62) sts.

2nd row: K19 (24). Sl1K. K1.

pssso. K1. Sl1P. K4. Sl1P. K1.

K2tog. K19 (24). 50 (60) sts.

3rd row: K18 (23). Sl1K. K1.

pssso. P10. K2tog. K18 (23).

48 (58) sts.

4th row: K17 (22). Sl1K. K1.

pssso. K1. Sl1P. K4. Sl1P. K1.

K2tog. K17 (22). 46 (56) sts.

5th row: K16 (21). Sl1K. K1.

pssso. K1. P1. K4. P1. K1. K2tog.

K16 (21). 44 (54) sts.

6th row: K15 (20). Sl1K. K1.

pssso. K1. Sl1P. K4. Sl1P. K1.

K2tog. K15 (20). 42 (52) sts.

Check pat is now in position.

Keeping cont of check pat, dec 2 sts every row, as before, until there are 36 (42) sts, ending with RS facing for next row.

Next 2 rows: K13 (16). Pat across 10 sts. K13 (16).

Next row: (Eyelet row). K1. *yfw. K2tog. Rep from * to last st. K1.

Next row: Purl. Break MC.

With A, work 14 rows garter st (knit every row). Cast off.

Sew back and sole seam.

Twisted cord: (make 2). Cut 4 strands of A, 20 ins [51 cm] long. With all strands tog hold one end and with someone holding other end, twist strands to the right until they begin to curl. Fold the 2 ends tog and tie in a knot so they will not unravel.

The strands will now twist themselves tog. Adjust length if desired.

Thread cord through eyelet row of Bootie.

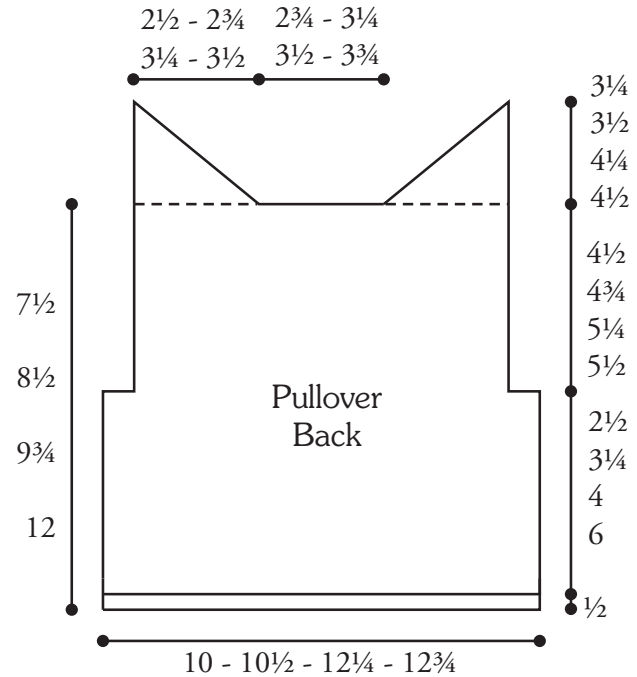
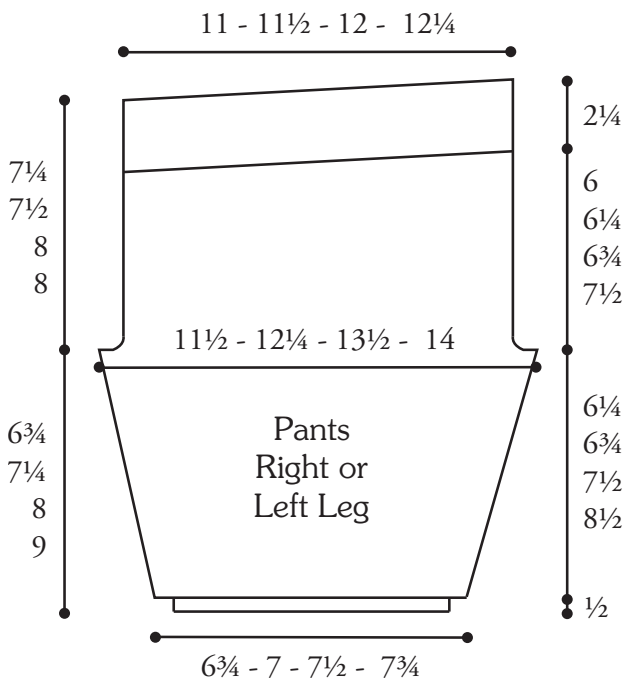
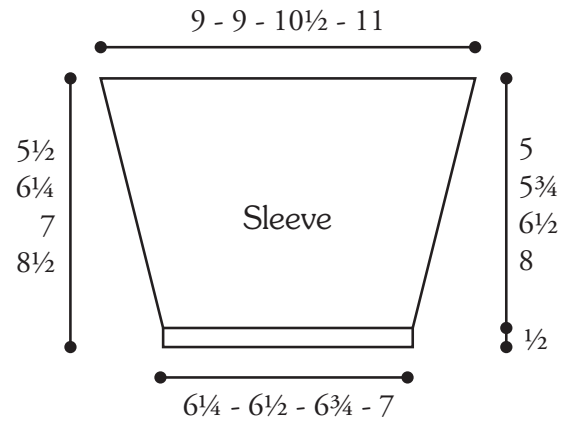
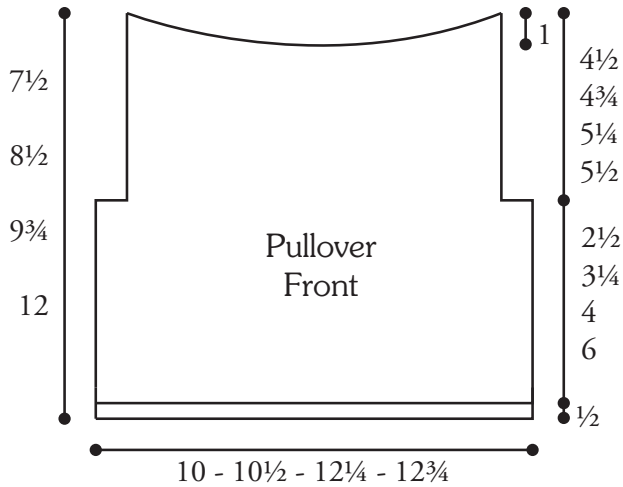

Patons

... a part of your life.

P.O. Box 40, Listowel ON N4W 3H3