

**Patons**  
*Classic Wool*

**Patons**  
**Canadiana**

**Patons**  
**DECOR**



## ELEGANT DETAILS

### SIZES

#### Bust measurement

Small	30-32 ins	[76-81cm]
Medium	34-36 ins	[86-91cm]
Large	38-40 ins	[97-102cm]

#### Finished bust

Small	36 ins	[91 cm]
Medium	38 ins	[97 cm]
Large	40 ins	[102 cm]

## MATERIALS

**Patons Classic Wool** (100 g/3.5 oz)  
or **Patons Décor** (100 g/3.5 oz)  
or **Patons Canadiana** (100 g/3.5 oz)

<b>Size</b>	<b>S</b>	<b>M</b>	<b>L</b>	
	8	9	10	balls

Sizes 4 mm (U.S. 6) and 5 mm (U.S. 8) knitting needles. Size 4 mm (U.S. 6) circular knitting needle 16 ins [40 cm] long **or size needed to obtain tension**. Cable needle. 2 st holders.

## TENSION

19 sts and 25 rows = 4 ins [10 cm]  
with larger needles in stocking st.

## ABBREVIATIONS

**Inc 1** = Knit into front and back of next st.

**KB1** = Knit into back of next st.

**SI2** = Slip next 2 sts knitways.

**P2sso** = Pass 2 slipped sts over last st.

**M5** = (Make 5 sts in next st). [(K1. yfwd) twice. K1] all in next st.

**Tw2L** = knit into back of 2nd st on left hand needle, then knit into front of first st, slipping both sts off needle together.

**Tw2R** = knit into front of 2nd st on left hand needle, then knit into front of first st, slipping both sts off needle together.

**C8F** = slip next 5 sts onto cable needle and hold at front of work, KB1. P1. KB1. Slip 4th and 5th sts from cable needle onto left-hand needle. P2, then (KB1. P1. KB1) from cable needle.

## INSTRUCTIONS

*The instructions are written for smallest size. If changes are necessary for larger sizes the instructions will be written thus ( ).*

### PANEL PAT A

(worked over 18 sts)

**1st row:** (RS). Purl.

**2nd row:** Knit.

**3rd row:** P9. M5. P8.

**4th row:** K8. P5. K9.

**5th row:** P9. K1. SI2. K1. P2sso. K1. P8.

**6th row:** K8. P3tog. K9.

**7th row:** P6. M5. P2. KB1. P2. M5. P5.

**8th row:** K5. P5. K2. P1. K2. P5. K6.

**9th row:** P6. K1. SI2. K1. P2sso. K1. P2. KB1. P2. K1. SI2. K1. P2sso. K1. P5.

**10th row:** K5. P3tog. K2. P1. K2. P3tog. K6.

**11th row:** P3. M5. (P2. KB1) 3 times. P2. M5. P2.

**12th row:** K2. P5. (K2. P1) 3 times. K2. P5. K3.

**13th row:** P3. K1. SI2. K1. P2sso. K1. (P2. KB1) 3 times. P2. K1. SI2. K1. P2sso. K1. P2.



ABBREVIATIONS: [www.patonsyarns.com/glossary](http://www.patonsyarns.com/glossary)

**14th row:** K2. P3tog. (K2. P1) 3 times. K2. P3tog. K3.  
**15th row:** M5. (P2. KB1) 5 times. P2.  
**16th row:** (K2. P1) 5 times. K2. P5.  
**17th row:** K1. Sl2. K1. P2sso. K1. (P2. KB1) 5 times. P2.  
**18th row:** (K2. P1) 5 times. K2. P3tog.  
**19th row:** (KB1. P2) 6 times.  
**20th row:** (K2. P1) 6 times.  
**21st row:** KB1. P2. (Tw2L. P1) twice. KB1. (P1. Tw2R) twice. P2.  
**22nd row:** K3. P1. K2. (P1. K1) twice. P1. K2. P1. K3. P1.  
**23rd row:** KB1. P2. M5. Tw2L. P1. Tw2L. KB1. Tw2R. P1. Tw2R. M5. P2.  
**24th row:** K2. P5. K1. P1. K2. P3. K2. P1. K1. P5. K2. P1.  
**25th row:** KB1. P2. K1. Sl2. K1. P2sso. K1. P1. Tw2L. P2. KB1. P2. Tw2R. P1. K1. Sl2. K1. P2sso. K1. P2.  
**26th row:** K2. P3tog. (K2. P1) 3 times. K2. P3tog. K2. P1.  
**27th row:** (KB1. P2) twice. Tw2L. P1. KB1. P1. Tw2R. P2. KB1. P2.  
**28th row:** K2. P1. K3. (P1. K1) twice. P1. K3. P1. K2. P1.  
**29th row:** (KB1. P2) twice. M5. Tw2L. KB1. Tw2R. M5. P2. KB1. P2.  
**30th row:** K2. P1. K2. P5. K1. P3. K1. P5. (K2. P1) twice.  
**31st row:** (KB1. P2) twice. K1. Sl2. K1. P2sso. K1. P2. KB1. P2. K1. Sl2. K1. P2sso. K1. P2. KB1. P2.  
**32nd row:** K2. P1. K2. P3tog. K2. P1. K2. P3tog. (K2. P1) twice.  
**33rd row:** As 19th row.

**34th row:** (K2. P1) twice. K5. (P1. K2) twice. P1.  
**35th row:** (KB1. P2) 3 times. M5. (P2. KB1) twice. P2.  
**36th row:** (K2. P1) twice. K2. P5. (K2. P1) 3 times.  
**37th row:** (KB1. P2) 3 times. K1. Sl2. K1. P2sso. K1. (P2. KB1) twice. P2.  
**38th row:** (K2. P1) twice. K2. P3tog. (K2. P1) 3 times.  
**39th row:** As 19th row.  
**40th row:** As 34th row.  
**41st row:** (KB1. P2) twice. Slip next 4 sts onto cable needle and hold in front of work. (KB1. P1. KB1) over next 3 sts. Slip 3rd and 4th sts from cable needle back onto left needle. P1. Slip 1st and 2nd sts from cable needle back onto left needle. KB1. P1. (KB1. P2.) twice.  
**42nd row:** K2. P1. K2. P1. K1. P1. Inc1. P1. K1. P1. (K2. P1) twice. 19 sts.  
These 42 rows form Panel Pat A.  
**PANEL PAT B** (worked over 9 sts)  
**1st row:** (RS). Purl.  
**2nd row:** Knit.  
**3rd row:** M5. P8.  
**4th row:** K8. P5.  
**5th row:** K1. Sl2. K1. P2sso. K1. P8.  
**6th row:** K8. P3tog.  
**7th row:** KB1. P2. M5. P5.  
**8th row:** K5. P5. K2. P1.  
**9th row:** KB1. P2. K1. Sl2. K1. P2sso. K1. P5.

**10th row:** K5. P3tog. K2. P1.  
**11th row:** (KB1. P2) twice. M5. P2.  
**12th row:** K2. P5. (K2. P1) twice.  
**13th row:** (KB1. P2) twice. K1. Sl2. K1. P2sso. K1. P2.  
**14th row:** K2. P3tog. (K2. P1) twice.  
**15th row:** (KB1. P2) 3 times.  
**16th row:** (K2. P1) 3 times.  
**17th to 20th rows:** As 15th and 16th rows twice.  
**21st row:** KB1. P1. Tw2R. P1. Tw2R. P2.  
**22nd row:** K3. P1. K2. P1. K1. P1.  
**23rd row:** KB1. Tw2R. P1. Tw2R. M5. P2.  
**24th row:** K2. P5. K1. P1. K2. P2.  
**25th row:** KB1. P2. Tw2R. P1. K1. Sl2. K1. P2sso. K1. P2.  
**26th row:** K2. P3tog. (K2. P1) twice.  
**27th row:** KB1. P1. Tw2R. P2. KB1. P2.  
**28th row:** K2. P1. K3. P1. K1. P1.  
**29th row:** KB1. Tw2R. M5. P2. KB1. P2.  
**30th row:** K2. P1. K2. P5. K1. P2.  
**31st row:** KB1. P2. K1. Sl2. K1. P2sso. K1. P2. KB1. P2.  
**32nd row:** K2. P1. K2. P3tog. K2. P1.  
**33rd to 42nd rows:** As 15th and 16th rows 5 times.  
These 42 rows form Panel Pat B.

## PANEL PAT C

(worked over 10 sts)

**1st row:** (RS). Purl.

**2nd row:** Knit.

**3rd row:** P9. M5.

**4th row:** P5. K9.

**5th row:** P9. K1. Sl2. K1. P2sso. K1.

**6th row:** P3tog. K9.

**7th row:** P6. M5. P2. KB1.

**8th row:** P1. K2. P5. K6.

**9th row:** P6. K1. Sl2. K1. P2sso. K1. P2. KB1.

**10th row:** P1. K2. P3tog. K6.

**11th row:** P3. M5. (P2. KB1) twice.

**12th row:** (P1. K2) twice. P5. K3.

**13th row:** P3. K1. Sl2. K1. P2sso. K1. (P2. KB1) twice.

**14th row:** (P1. K2) twice. P3tog. K3.

**15th row:** M5. (P2. KB1) 3 times.

**16th row:** (P1. K2) 3 times. P5.

**17th row:** K1. Sl2. K1. P2sso. K1. (P2. KB1) 3 times.

**18th row:** (P1. K2) 3 times. P3tog.

**19th row:** (KB1. P2) 3 times. KB1.

**20th row:** (P1. K2) 3 times. P1.

**21st row:** KB1. P2. (Tw2L. P1) twice KB1.

**22nd row:** P1. K1. P1. K2. P1. K3. P1.

**23rd row:** KB1. P2. M5. Tw2L. P1. Tw2L. KB1.

**24th row:** P2. K2. P1. K1. P5. K2. P1.

**25th row:** KB1. P2. K1. Sl2. K1. P2sso. K1. P1. Tw2L. P2. KB1.

**26th row:** (P1. K2) twice. P3tog. K2. P1.

**27th row:** (KB1. P2) twice. Tw2L. P1. KB1.

**28th row:** P1. K1. P1. K3. P1. K2. P1.

**29th row:** (KB1. P2) twice. M5. Tw2L. KB1.

**30th row:** P2. K1. P5. (K2. P1) twice.

**31st row:** (KB1. P2) twice. K1. Sl2. K1. P2sso. K1. P2. KB1.

**32nd row:** P1. K2. P3tog. (K2. P1) twice.

**33rd to 42nd rows:** As 19th and 20th rows 5 times.

These 42 rows form Panel Pat C.

## PANEL PAT D

(worked over 19 sts)

**1st and alt rows:** (RS). (KB1. P2) twice. KB1. P1. KB1. P2. KB1. P1. (KB1. P2) twice.

**2nd and alt rows:** (K2. P1) twice. K1. P1. K2. P1. K1. (P1. K2) twice. P1.

**13th row:** (KB1. P2) twice. C8F. P2. KB1. P2.

**14th row:** As 2nd row.

These 14 rows form Panel Pat D.

## BACK

\*\*With smaller needles cast on 111 (115-121) sts.

Beg with a knit row, work 5 rows in stocking st. Place marker at each end of last row (fold line).

With larger needles proceed in pat as follows:

**1st row:** (RS). P1 (3-6). Work 1st row panel pat B. (Work 1st row panel pat A) 5 times. Work 1st row panel pat C. P1 (3-6).

**2nd row:** K1 (3-6). Work 2nd row panel pat C. (Work 2nd row panel pat A) 5 times. Work 2nd row panel pat B. K1 (3-6).

Panel pats are now in position.

Cont in pat working appropriate row panel pats for 4 more rows.

**7th row:** P1 (3-3). (K1. P2) 0 (0-1) time. Work 7th row panel pat B. (Work 7th row panel pat A) 5 times. Work 7th row panel pat C. P1 (3-2). (K1. P3) 0 (0-1) time.

**8th row:** K1 (3-3). (P1. K2) 0 (0-1) time. Work 8th row panel pat C. (Work 8th row panel pat A) 5 times. Work 8th row panel pat B. K1 (3-2). (P1. K3) 0 (0-1) time.

These 8 rows form side pat.

Cont in pat, working appropriate row of panel pats, for 34 more rows. 116 (120-126) sts.

**Size S only: 43rd row:** P1. (KB1. P2tog) 3 times. (Work 1st row panel pat D) 5 times. (KB1. P2tog) 3 times. KB1. P1. 110 sts.

**44th row:** (K1. P1) 4 times. (Work 2nd row panel pat D) 5 times. (K1. P1) 3 times. K1.

**45th row:** P1. (KB1. P1) 3 times. (Work 3rd row of Panel Pat D) 5 times. (KB1. P1) 3 times. KB1. P1.

**46th row:** (K1 P1) 4 times. (Work 4th row of Panel Pat D) 5 times. (K1. P1) 3 times. K1.

**Size M only: 43rd row:** P1. P2tog. (KB1. P2tog) twice. KB1. P2. (Work 1st row panel pat D) 5 times. KB1. P2. (KB1. P2tog) twice. KB1. P2tog. P1. 114 sts.

**44th row:** K2. (P1. K1) twice. (K2. P1) twice. (Work 2nd row panel pat D) 5 times. (K1. P1) 3 times. K1.

**45th row:** P2. (KB1. P1) twice. KB1 P2. (Work 3rd row of Panel Pat D) 5 times. KB1. P2. (KB1. P1) twice. KB1. P2.

**46th row:** K2. (P1. K1) twice (K2. P1) twice. (Work 4th row of Panel Pat D) 5 times (K1. P1) 3 times. K1.

**Size L only: 43rd row:** P1. (P2tog. KB1) 3 times. P2. KB1. P2. (Work 1st row panel pat D) 5 times. (KB1. P2) twice. (KB1. P2tog) 3 times. P1. 120 sts.

**44th row:** K2. (P1. K1) twice. P1. (K2. P1) twice. (Work 2nd row panel pat D) 5 times. (K2. P1) twice. (K1. P1) twice. K2.

**45th row:** P2. (KB1. P1) twice. (KB1. P2) twice. (Work 3rd row of Panel Pat D) 5 times. (KB1. P2) twice. (KB1. P1) 3 times. P1.

**46th row:** K1. (K1. P1) 3 times. (K2. P1) twice. (Work 4th row of Panel Pat D) 5 times. (K2. P1) twice. (K1. P1) twice. K2.

**All sizes:** Pat is now in position. Cont in pat until work from fold line measures 15½ (16-16½) ins [39 (40.5-42) cm] ending with RS facing for next row.

**Armhole shaping:** Keeping cont of pat, cast off 4 sts beg next 2 rows. Dec 1 st each end of next 5 rows, then following alt row. 90 (94-100) sts.\*\*

Cont even in pat until work from fold line measures 23 (24-25) ins [58.5 (61-63.5) cm] ending with RS facing for next row.

**Shoulder shaping:** Cast off 9 (9-10) sts beg next 4 rows, then 9 (10-10) sts beg following 2 rows. Leave rem 36 (38-40) sts on a st holder.

## FRONT

Work from \*\* to \*\* as given for Back.

Cont even in pat until Front from fold line measures 20½ (21½-22¼) ins [52 (54.5-56.5) cm] ending with RS facing for next row.

**Neck shaping: Next row:** Pat across 35 (36-38) sts (neck edge). **Turn.** Leave rem sts on a spare needle.

Dec 1 st at neck edge on next 2 rows and following alt rows to 26 (28-30) sts.

Cont even in pat until Front from fold line measures same length as Back to beg of shoulder shaping, ending with RS facing for next row.

**Shoulder shaping:** Cast off 9 (9-10) sts beg next and following alt row. Cast off rem 9 (10-10) sts.

With RS of work facing slip next 20 (22-24) sts from spare needle onto a st holder. Join yarn to rem sts and pat to end of row.

Dec 1 st at neck edge on next 2 rows and following alt rows to 26 (28-30) sts.

Cont even in pat until Front from fold line measures same length as Back to beg of shoulder shaping ending with **WS** facing for next row.

**Shoulder shaping:** Cast off 9 (9-10) sts beg next and following alt row. Cast off rem 9 (10-10) sts.

## SLEEVES

With smaller needles, cast on 59 sts. Work 5 rows in stocking st as given for Back. Place marker at each end of last row (fold line).

Change to larger needles and proceed in pat as follows:

**1st row:** P2. (Work 1st row panel pat A) 3 times. P3.

**2nd row:** K3. (Work 2nd row panel pat A) 3 times. K2.

Panel pats are now in position.  
These 2 rows form pat.

Keeping cont of pat, work appropriate rows of panel pat A for 12 more rows.

**15th row:** P2. (Work 15th row panel pat A) 3 times. M5. P2.

**16th row:** K2. P5. (Work 16th row panel pat A) 3 times. K2.

**17th row:** P2. (Work 17th row panel pat A) 3 times. K1. Sl2. K1. P2sso. K1. P2.

**18th row:** K2. P3tog. (Work 18th row panel pat A) 3 times. K2.

**19th row:** P2. (Work 19th row panel pat A) 3 times. KB1. P2.

**20th row:** K2. P1. (Work 20th row panel pat A) 3 times. K2.

Panel pats are now in position.

Keeping cont of pat, work appropriate rows of panel pat A for 22 more rows. 62 sts.

**Next row:** P2. (Work 1st row panel pat D) 3 times. KB1. P2.

**Next row:** K2. P1. (Work 2nd row panel pat D) 3 times. K2.

Panel pats are now in position.

Cont in pat, working appropriate rows of panel pat D, inc 1 st at each end of next and every following 4th row to 86 (92-94) sts, taking inc sts into side rib pat.

Cont even in pat until sleeve from fold line measures 17½ (18-18½) ins [44.5 (45.5-47) cm] ending with RS facing for next row.

**Top shaping:** Keeping cont of pat, cast off 4 sts beg next 2 rows. Dec 1 st each end of next and following 6 (7-8) alt rows, then on every row to 58 (62-62) sts. Cast off 3 sts beg next 8 rows. Cast off rem 34 (38-38) sts.

### FINISHING

Block all pieces to measurements, cover with a damp cloth and allow to dry.

**Neckband:** Sew right shoulder seam. With RS of work facing and circular needle pick up and knit 14 (17-18) sts down left front neck edge. Pat across 20 (22-24) sts from st holder. Pick up and knit 14 (17-18) sts up right front neck edge. Pat across 36 (38-40) sts from back st holder. 84 (94-100) sts.

**Size S only: Next row:** (WS). Pat across 36 sts. (K2. P1) 4 times. K2. Pat across 20 sts. (K2. P1) 4 times. K2.

**Size M only: Next row:** (WS). Pat across 38 sts. K1. (P1. K2) 5 times. P1. Pat across 22 sts. (P1. K2) 5 times. P1. K1.

**Size L only: Next row:** (WS). Pat across 40 sts. (P1. K2) 5 times. P1. K1. P1. Pat across 24 sts. P1. K1. P1. (K2. P1) 5 times.

**All sizes:** Cont in rib pat until work measures 3 ins [7.5 cm], ending with RS facing for next row. Cast off.

Sew left shoulder and neckband seam. Sew in sleeves. Sew side and sleeve seams. Fold bottom of Front, Back and Sleeve to **WS** along fold line and sew in position.

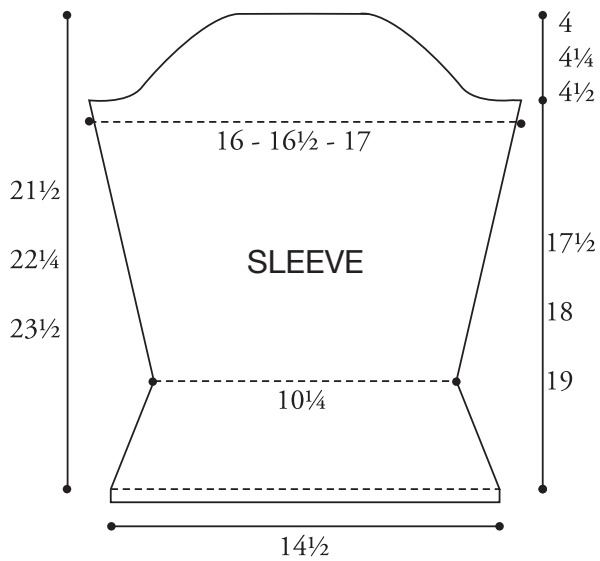
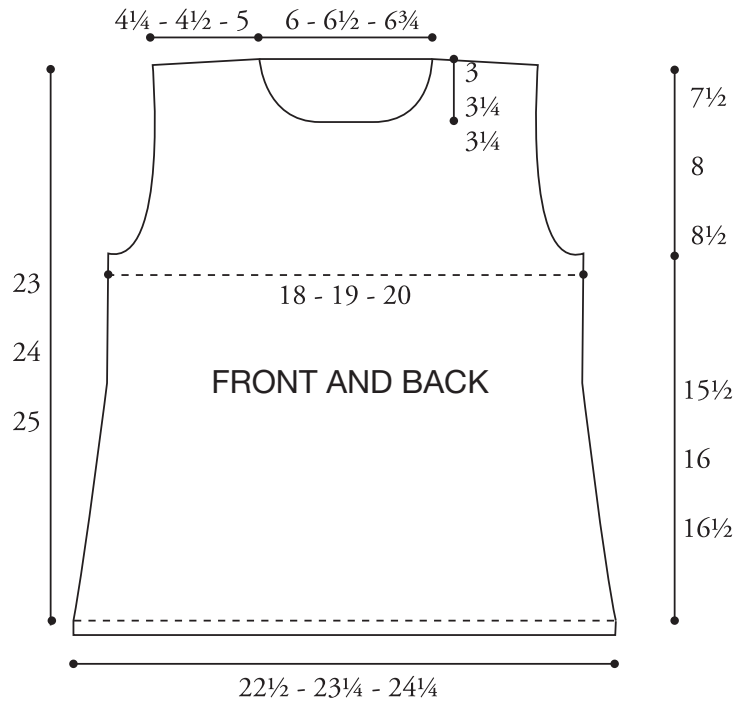

 **Patons**

*... a part of your life.*

P.O. Box 40, Listowel ON N4W 3H3