



CROCHET | SKILL LEVEL: **EASY**

ABBREVIATIONS

Beg = Begin(ning)
Ch = Chain(s)
Cont = Continue(ity)
PM = Place marker
Rem = Remain(ing)
Rep = Repeat
Rnd(s) = Round(s)
RS = Right side
Sc = Single crochet

Sc2tog = Draw up a loop in each of next 2 stitches. Yoh and draw through all loops on hook.
Sl st = Slip stitch
St(s) = Stitch(es)
Tog = Together
WS = Wrong side
Yoh = Yarn over hook

SIZES

To fit chest measurement

XS/XL 28-46" [71-117 cm]

2/5XL 48-62" [122-157.5 cm]

Finished chest measurement

XS/XL 65" [165 cm]

2/5XL 84" [213.5 cm]

GAUGE

8 sc and 9 rows = 4" [10 cm].

INSTRUCTIONS

The instructions are written for XS/XL. If changes are necessary for larger size the instruction will be written XS/XL (2/5XL). Numbers for each size are shown in the same color throughout the pattern. When only one number is given in black, it applies to both sizes.

Notes:

- Hoodie is worked in 5 pieces and seamed together in Finishing.
- Hood is worked from neck in Finishing.

MATERIALS

Bernat® Forever Fleece™ (9.9 oz/280 g; 194 yds/177 m)

Sizes	XS/XL	2/5XL	
Corduroy (61028)	10	14	balls
	1927/1762	2611/2387.5	yds/m

Size U.S. M/13 (9 mm) Susan Bates® Silvalume® crochet hook **or size needed to obtain gauge.** Susan Bates® stitch markers. Susan Bates® yarn needle.

BACK

****Ribbing:** Ch 5.

1st row: (RS). 1 sc in 2nd ch from hook. 1 sc in each ch to end of chain. Turn. 4 sc.

2nd row: Ch 1. *Working in back loops only*, 1 sc in each sc to end of row. Turn.

Rep last row until work from beg measures **32½ (42)" [82.5 (106.5) cm]**, when slightly stretched, ending on a RS row. **Do not** fasten off.

Proceed as follows:

Set-up row: (RS). Turn work sideways. Ch 1. Work **65 (83)** sc evenly along side of Ribbing. Turn. PM at end of row.

Next row: Ch 1. 1 sc in each sc to end of row. Turn.**

Rep last row until work from marker measures **33 (36)" [84 (91.5) cm]**, ending on a WS row. Fasten off.

FRONT

Work from ** to ** as given for Back. Rep last row until work from marker measures **27 (28½)" [68.5 (72.5) cm]**, ending on a WS row.

Shape Left Front Neck: 1st row:

(RS). Ch 1. 1 sc in each of first **29 (38)** sc. **Turn.** Leave rem sts unworked. PM at end of row.

*****2nd row:** Ch 1. 1 sc in each sc to end of row. Turn.

Rep last row until work from marker measures **6 (7½)" [15 (19) cm]**, ending on a WS row. Fasten off.***

Shape Right Front Neck: 1st row:

(RS). Skip next 7 sc after Left Front neck. Join yarn with sl st to next sc. Ch 1. 1 sc in same sc as last sl st. 1 sc in each of last **28 (37)** sc. Turn. PM at end of row. **29 (38)** sc.

Rep from *** to *** as given for Left Front Neck.

SLEEVES

Ribbing: Ch 5.

1st row: (RS). 1 sc in 2nd ch from hook. 1 sc in each ch to end of chain. Turn. 4 sc.

2nd row: Ch 1. *Working in back loops only*, 1 sc in each sc to end of row. Turn.

Rep last row until work from beg measures **10 (11½)" [25.5 (29) cm]**, when slightly stretched, ending on a RS row. **Do not** fasten off.

Proceed as follows:

Set up row: (RS). Turn work sideways. Ch 1. Work **19 (23)** sc evenly along side of Ribbing. Turn. PM at end of row.

1st row: (WS). Ch 1. 2 sc in first sc. 1 sc in each sc to last sc. 2 sc in last sc. Turn. **21 (25)** sc.

2nd and 3rd rows: As 1st row.

4th row: (RS). Ch 1. 1 sc in each sc to end of row. Turn.

Rep 1st to 4th rows 5 times more, then rep **1st row (1st to 3rd rows)** once, ending on a WS row. **57 (65)** sc.

Fasten off.

FINISHING

Sew shoulder seams **11¼ (15)" [28.5 (38) cm]** in from side edges leaving **10 (12)" [25.5 (30.5) cm]** center back neck opening. PM **14 (16)" [35.5 (40.5) cm]** down from shoulders on side edges. Sew in sleeves between markers. Sew side and sleeve seams.

HOOD

1st row: (RS). Beg at right front neck, join yarn with sl st to first sc. Ch 1. Work **6 (8)** sc evenly up right front neck, **20 (24)** sc evenly across back neck edge and **6 (8)** sc evenly down left front neck. Turn. PM at end of row. **32 (40)** sc.

2nd row: Ch 1. 1 sc in each sc to end of row. Turn.

3rd row: Ch 1. 1 sc in each of first 2 sc. [2 sc in next sc. 1 sc in next **2 (4) sc] 9 (7)** times. 2 sc in next sc. 1 sc in each of last 2 sc. Turn. **42 (48)** sc.

4th row: Ch 1. 1 sc in each sc to end of row. Turn. **42 (48)** sc.

Rep 4th row until Hood from marker measures **13 (16)" [33 (40.5) cm]**, ending on a WS row.

Next row: (RS). Ch 1. 1 sc in each of first **19 (22)** sc. (Sc2tog) twice. 1 sc in each of last **19 (22)** sc. Turn. **40 (46)** sts.

Next 2 rows: Ch 1. 1 sc in each st to end of row. Turn.

Next row: Ch 1. 1 sc in each of first **18 (20)** sc. (Sc2tog) twice. 1 sc in each of last **18 (20)** sc. Turn. **38 (44)** sts.

Next row: Ch 1. 1 sc in each st to end of row. Fasten off.

Fold Hood in half and sew top seam.

Hood Edging: 1st row: (RS). Join yarn with sl st to bottom corner of right front neck opening. Ch 1. Work **83 (102)** sc evenly up side of right neck edge, across Hood opening, and down side of left neck edge. Turn.

2nd to 4th rows: Ch 1. 1 sc in each sc to end of row. Turn. Fasten off. Sew ends of Hood Edging to bottom of neck opening (7 skipped sts). Sew edges of Hood Edging tog 2" [5 cm] up from Bottom of neck opening.

POCKET

Ch **35 (39)**.

1st row: (RS). 1 sc in 2nd ch from hook. 1 sc in each ch to end of chain. Turn. **34 (38)** sc.

2nd to 7th rows: Ch 1. 1 sc in each sc to end of row. Turn.

8th row: (WS). Ch 1. 1 sc in each of first 2 sc. Sc2tog. 1 sc in each sc to last 4 sc. Sc2tog. 1 sc in each of last 2 sc. Turn. **32 (36)** sts.

9th row: Ch 1. 1 sc in each sc to end of row. Turn.

Rep 8th and 9th rows **4 (5)** times more. **24 (26)** sc rem, ending on a RS row.

Next 4 rows: Ch 1. 1 sc in each sc to end of row. **Do not** turn at end of 4th row.

Cont working edging around Pocket as follows:

1st rnd: (RS). Ch 1. Work sc evenly around Pocket, working 3 sc in each corner. Join with sl st to first sc. Fasten off.

Sew Pocket in position centered across Front and 11" [28 cm] above bottom edge (*see diagram on page 4*).

EARS (make 2)

Note: Do not join at ends of rnds unless otherwise stated. Cont working in spiral, PM on first st of rnd for easier counting.

Ch 2.

1st rnd: 6 sc in 2nd ch from hook.

2nd rnd: 2 sc in each sc around. 12 sc.

3rd rnd: *1 sc in next sc. 2 sc in next sc. rep from * around. 18 sc.

4th to 7th rnds: 1 sc in each sc around.

8th rnd: *1 sc in each of next 4 sc. Sc2tog. Rep from * around. 15 sts.

9th rnd: *1 sc in each of next 2 sc. Sc2tog. Rep from * around. Join with sl st in first sc. 10 sts.

Fasten off.

Flatten Ear, pushing one side into the other, noting Ear will naturally cup. Fold last rnd in half, aligning cupped edges together. Sew last round together, working through all 4 thickness to close Ear.

Sew Ears into position, one on each side of Hood, approx 4" [10 cm] back from front edge and 1" [2.5 cm] down from top seam of Hood (as shown in photo).

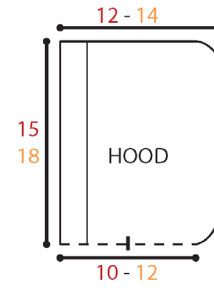
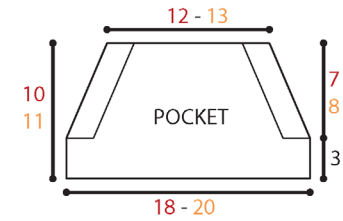
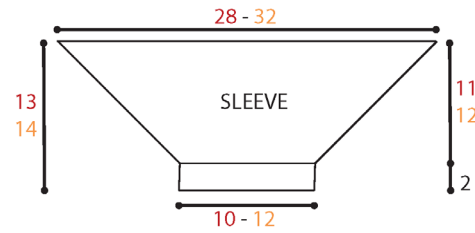
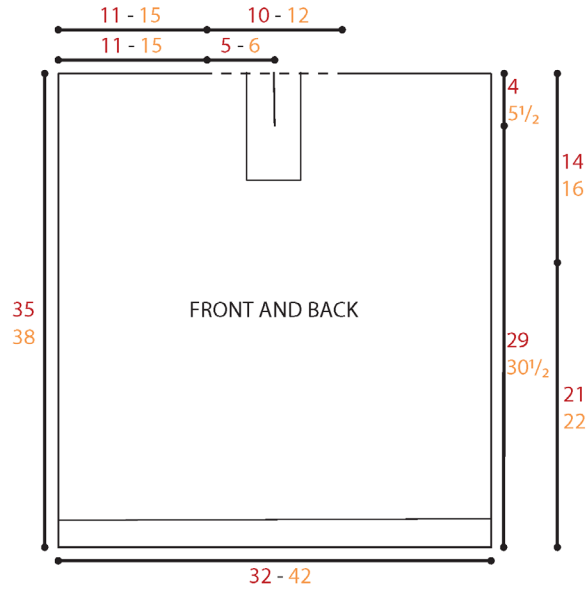

XS/XL

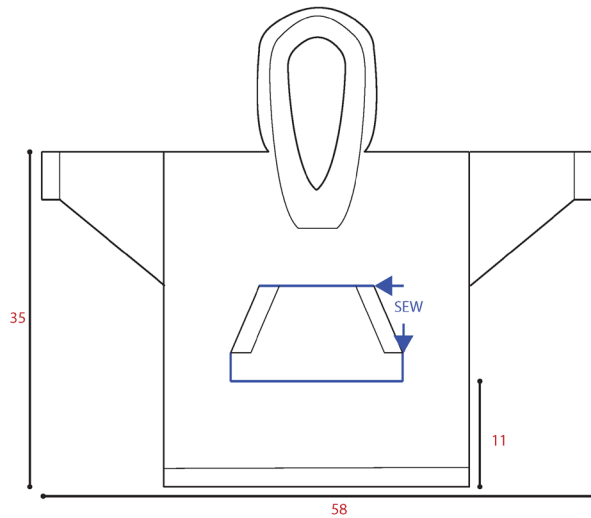

2/5XL

