

1 Option A:
Recommended pit to be cast in concrete.

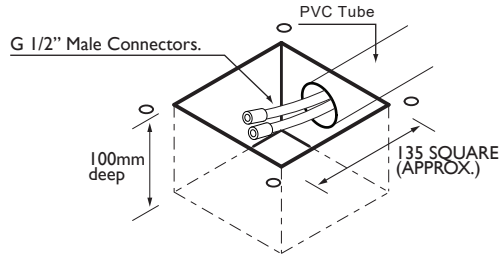

Option B:
Timber Floor Installation

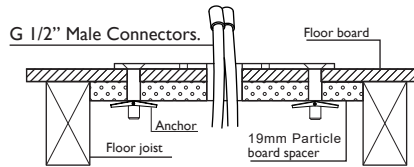

2
Locate Mounting Plate over cast pit and secure with M10 Dynabolts provided.

Tighten firmly.
Ensure Inlet Connectors are fed through opening in the Mounting Plate.

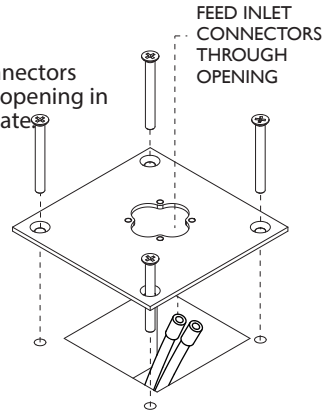

3
Connect hot and cold male connectors to the Inlet Body G 1/2 inch inlets. Tighten firmly.

Push TEST CAP into position. Fasten Pan Head Screws to secure the test cap.

TEST AND CHECK FOR LEAKS

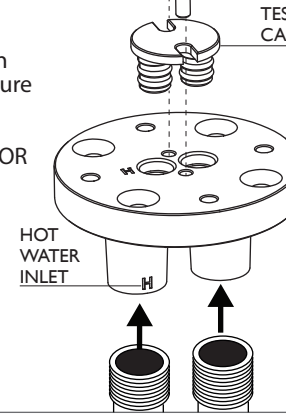

4
Fasten Inlet Body to Mounting Plate with 4 x M8 countersunk screws. Tighten firmly.

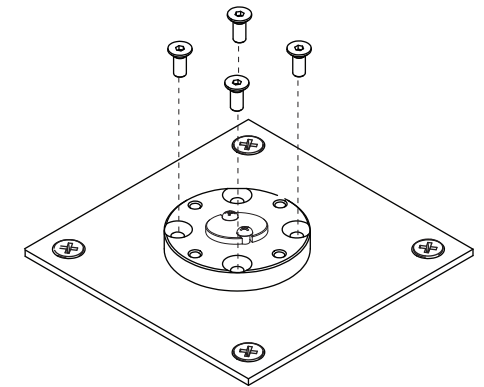

5a
Place Protective Cover over Inlet Body and fasten with 4 x M8 Hex Bolts provided.

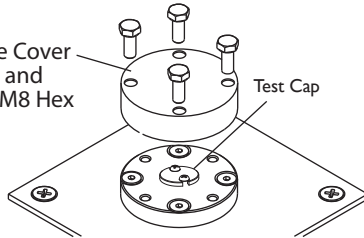

5b
Do not tile past the top edge of the Inlet Body

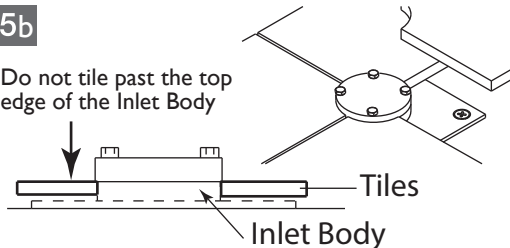

6a
Gently slide Dress Cover up Mixer Body.
Screw Mounting Flange onto Mixer Body. Tighten firmly.
Push Inlet Spigot Retainer into position.

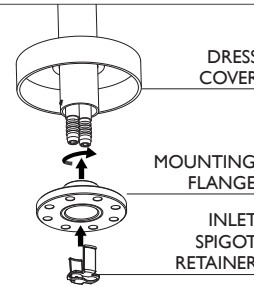

6b
Remove Protective Cover and Test Cap from Inlet Body.
Gently push Floor Mixer into position. Red O-Ring Spigot connects to Hot Outlet.

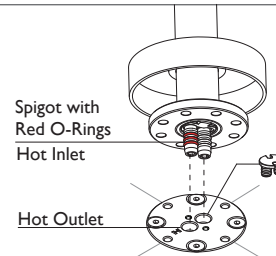

7
Fasten M8 Hex Bolts firmly to secure Floor Mixer.
For minor adjustment, rotate Floor Mixer to desired position and fasten the Grub Screw firmly.
Gently push down the Cover Plate over the Mount Plate.

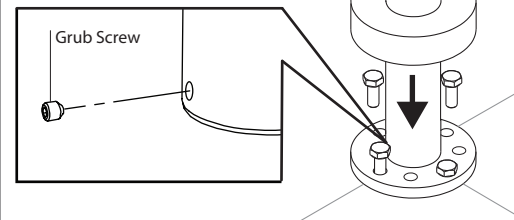

8 If Hand Shower is Provided, Continue as Indicated:

Make sure that rubber washers are installed into position.
Fasten the shower hose to G1/2 inch Thread with a spanner.
Screw the hand piece to the shower hose firmly by hand.

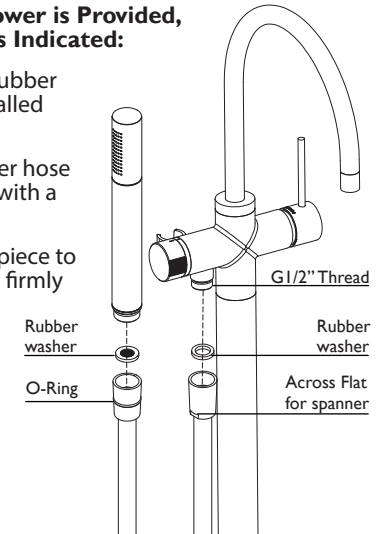

recommended working pressure
150-500 KPa
maximum hot water temperature
75 degrees

NOTE:
- If the pressure exceeds or is likely to exceed 550kpa, an approved pressure limiting device must be installed.
- Flush out all pipe work prior to installation.
- If the water temperature exceeds 75°C, an approved tempering valve must be fitted.
- Installation should comply with Australian standard AS3500.1 or relevant local authority requirements.
Showers may not be suitable for use within:
• Gravity-fed water systems

• Pressure supply less than 150kPa;
NOTE: The 500kPa maximum water supply pressure does not apply to fire service outlets.
Failure to comply with the above may void all warranties.
WARRANTY:
Please refer to the full warranty statement enclosed with the product before installing. Or visit www.phoenixtapware.com.au to download a

MAINTENANCE AND CARE:
- Products should be cleaned with mild liquid detergent or soap and water.
- Do not use cream cleaners or citrus based cleaning products, as they are abrasive.
- Use of unsuitable cleaning agents may damage the surface. Any damage caused in this way will not be covered by warranty.

DISCLAIMER:
While we aim to ensure the specifications shown are correct at the time of printing, Phoenix Tapware reserves the right to make modifications without prior notice. Always use the physical product measurements for mark-ups and roughing-in as the line drawing shown may differ from the actual product over time.
*All measurements are shown in millimeters.