

Lillian

RAIL SHOWER

444114

Rail:

- Made from stainless steel
- ABS slider and wall mounts
- Deluxe stainless steel elbow
- Rail thickness: 20mm
- 1.5 metre stainless steel flexible hose (PVC on matte black model)

Hand Piece:

- Single water flow setting
- Made from solid brass

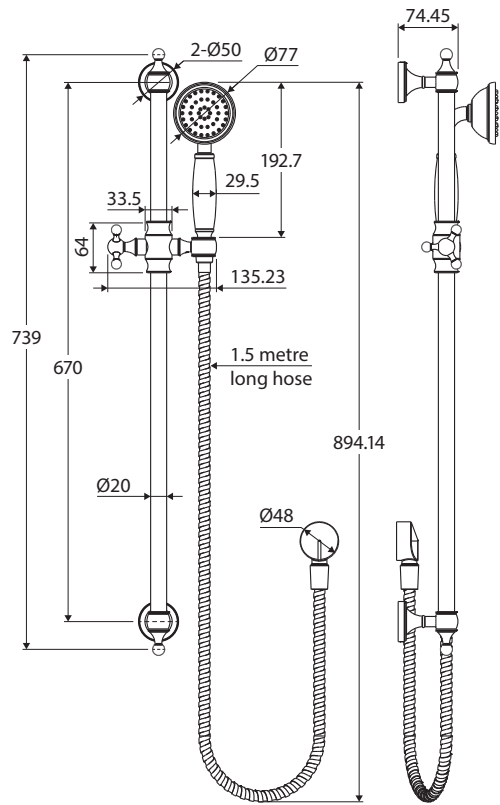

IMPORTANT: Please read all of the instructions before installation. Check the product thoroughly for damage. Installation is acceptance of goods supplied and will void warranty. This product is pre-assembled. Do not disassemble, as this may void the warranty.

Specifications

Please refer to fienza.com.au for the latest product specifications before installing.

Operating Pressure	Min: 150 kPa / 1.5 bar Max: 500 kPa / 5 bar Optimum: 150 kPa / 1.5 bar - 500 kPa / 5 bar Installation of pressure limiting valve recommended if supply exceeds 500kPa
Operating Temperature	Hot: Max 80°C Cold: Min. 5°C
Inlet Connections	1/2" BSPP
Suitable Hot Water Units	Storage tank and continuous flow only. Not suitable for gravity feed.
WELS Rating	3 Star rated, 8.5L/min

General Information

- This product must be installed by a qualified licensed plumber in accordance with AS/NZS 3500 and all applicable local regulations and plumbing codes.
- All pipe work must be thoroughly flushed prior to installation.
- Do not remove the ceramic cartridge from the mixer when installing.
- After installation all hoses and connections must be checked for leaks.
- It is the responsibility of the installer to ensure a waterproof seal is achieved between the product and mounting surface.

Installation

IMPORTANT:

- Before commencing installation, turn off the water supply. While not essential, we recommend fitting isolation valves to both the hot and cold-water supply.
- Some showers may not provide an effective shower when used with gravity fed heated water systems or where pressures are less than 150kPa at the outlet. Additionally, showers with flow rates of less than 9L/min may not allow the following to function correctly:
 - Some instantaneous water heaters
 - Some tempering valves
 - Some thermostatic mixing valves
- Some shower heads only operate correctly when hot and cold water supplies are both mains pressure and may not be suitable for some instantaneous hot water services.
- When water pressure is in excess of 500kPa a pressure limiting device is required.

- 1.** Recommended minimum height: 1000mm from floor level to water inlet position. Install a 1/2" male threaded connection at the appropriate height on wall, ensuring that a minimum of 13±2mm of thread protrudes past the finished wall. Correct water proofing must be applied.

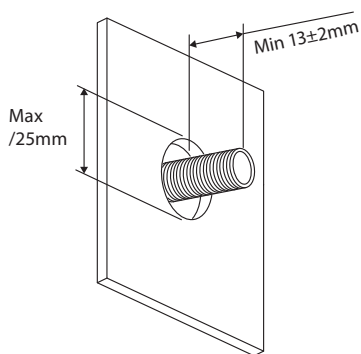

- 2.** Apply thread tape (or similar) to the 1/2" connection, then screw the water inlet connector to the connection.

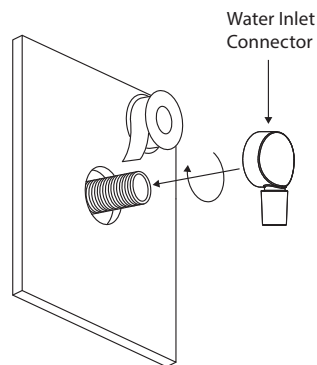

- 3.** Screw the rail connector to a wall stud making sure it is vertically in line with the top rail connector. Distance between the top and bottom shower connections is 670mm.

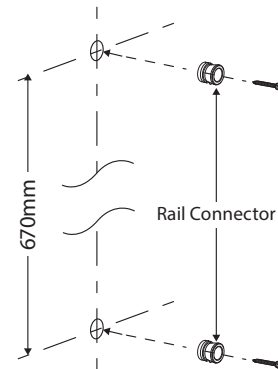

- 4.** Check the grub screws are wound tight. Push the rail brackets onto the top and bottom rail connectors until they are against the wall. Secure with grub screws. Secure with grub screws.

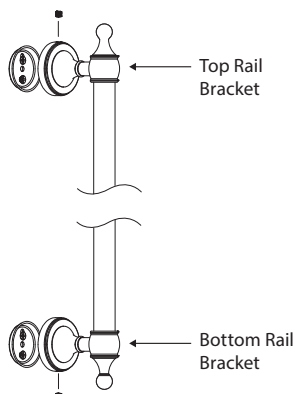

- 5.** Make sure a washer is in both ends of the hose. Screw hose onto the water inlet and onto the handset, place hand set firmly into the holder. Tilt and rotate the head to desired position.

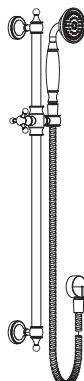

1	Screw
2	Base
3	Strut
4	Decorative Cap
5	Fixing Base
6	Rail
7	Handle Lever
8	Handle
9	Rod
10	Nut
11	M5 Screw
12	Nut
13	Fixing
14	Rubber Sleeve
15	Bracket
16	Rubber Sleeve
17	Connector
18	Rubber
19	Shower Holder
20	Rubber
21	Screw
22	Screw
23	Hand Shower
24	Elbow
25	Hose

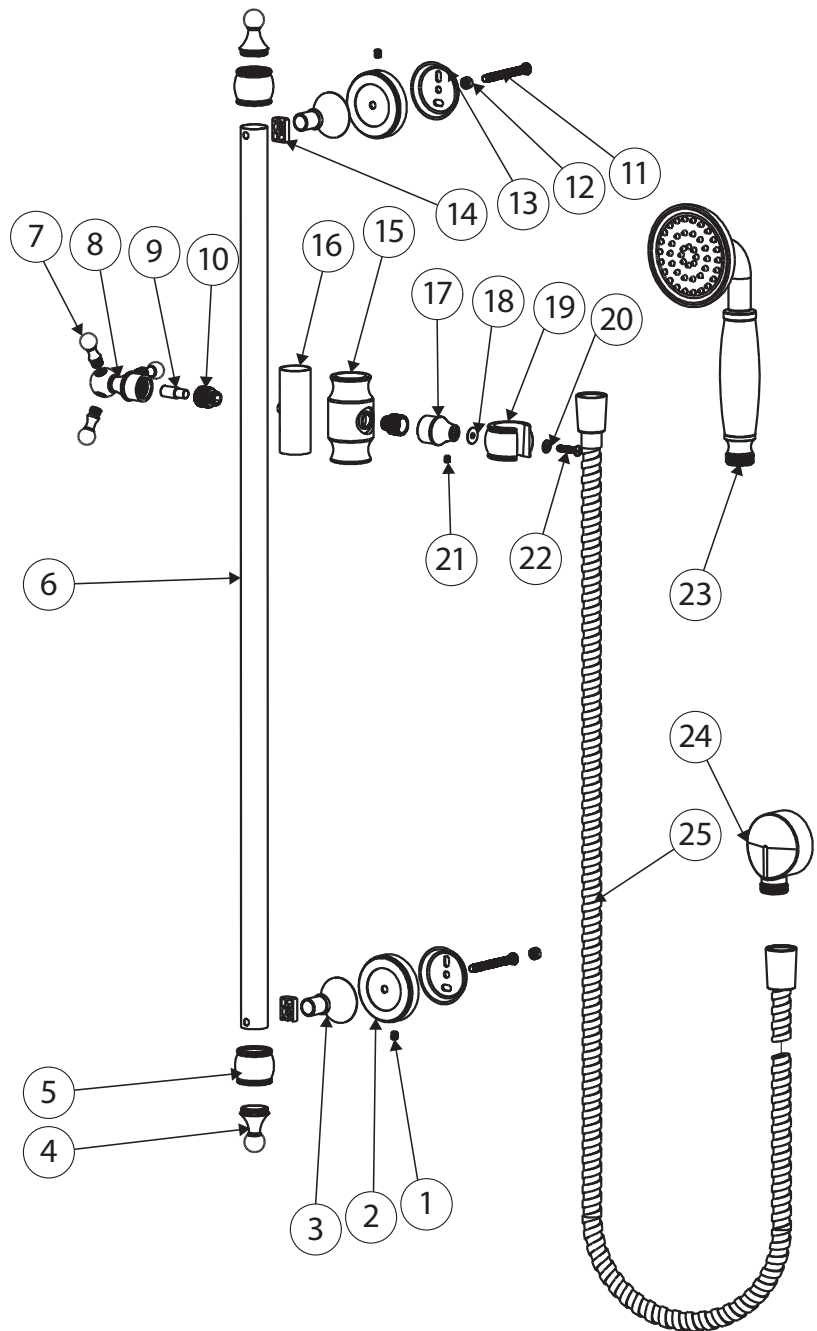

Cleaning & Care

We recommend weekly cleaning with mild soapy water and a microfibre cloth. In highly polluted or coastal locations we recommend cleaning 2-3 times per week. Please note that colour tapware requires more frequent cleaning than chrome tapware.

- Never use harsh detergents, citrus-based cleaners or abrasive cleaners, as these will scratch the surface. Use of unsuitable cleaners may damage the surface and will not be covered by warranty.
- Where your tapware remains dry in use, a non-abrasive soft cloth can be used to remove surface dust.
- Use of wax-based furniture creams should be avoided as these can result in a build-up of deposits which can effect the appearance.
- Do not use undue pressure and wipe in one direction only.

Warranties

At Fienza we pride ourselves on supplying products of a high standard. Our warranty periods are extremely competitive and practically designed to give the end user peace of mind.

Warranties for Domestic Use

The extended warranties below apply to domestic uses and applications of Fienza® products, such as private dwellings and retirement villages.

Product Component	Domestic Use
Shower Heads & Arms (Structural)	15 years replacement parts or product
Shower Rails (Structural)	15 years replacement parts or product; 1-year labour on Twin Rail Showers only
Shower Hoses	1-year replacement parts or product
Finishes (Chrome)	5 years replacement parts or product
Finishes (PVD)	10 years replacement parts or product; 1-year labour
Finishes (Electroplated)	5 years replacement parts or product; 1-year labour

Warranties for Commercial Use

The extended warranties below apply to commercial uses and applications of Fienza® products, including, but not limited to: commercial food premises such as restaurants; commercial accommodation such as hotels; hospitals and healthcare facilities; public amenities; and industrial, laboratory and manufacturing facilities.

Product Component	Commercial Use
Shower Heads & Arms (Structural)	7 years replacement parts or product
Shower Rails (Structural)	5 years replacement parts or product; 1-year labour on Twin Rail Showers only.
Shower Hoses	1-year replacement parts or product
Finishes (Chrome)	5 years replacement parts or product
Finishes (PVD)	5 years replacement parts or product; 1-year labour
Finishes (Electroplated)	1-year replacement parts or product; 1-year labour

PLEASE LEAVE THIS MANUAL WITH THE END USER

For warranty support, please contact Fienza



15 Walter Cres, Lawnton QLD 4501
 PO Box 5381, Brendale QLD 4500
P 07 3490 6700 **F** 07 3490 6719
E help@fienza.com.au ABN 76 136 411 311

Warranty Conditions

- Installation has been carried out by a licensed plumber in accordance with AS/NZS 3500 and all applicable local regulations and plumbing codes.
- All maintenance and adjustments to the product after the installation have been carried out by a licensed plumber.
- Cleaning and care instructions detailed in this document have been strictly adhered to.
- Proof of purchase is required for warranty claims.

Warranty Limitations

To the extent permitted under the Trade Practices Act and other relevant legislation, Fienza's liability is limited to:

- The cost of replacing the goods, or
- The cost of obtaining equivalent goods, or
- The cost of having the goods repaired
- Fienza is not responsible for any lack of operation or performance of goods (or any loss or damage) where goods are used or adapted for use with other goods not supplied by Fienza.
- It is the responsibility of the customer and installer before installation to ensure that all components are correct and free of obvious visible faults.
- Fienza is not responsible for the labour and rectification costs incurred in the above circumstance.

Conditions for On-Site Warranty Service Calls

Fienza will charge a service fee for each visit to an installation by its technician where it is determined that the fault is due to poorly executed or unlicensed installation work or where the product is not a genuine Fienza product or where the product is outside the warranty period. This may be paid in advance by credit card over the phone to a Fienza technician attending the site and will be refunded if the Fienza product is found to be at fault.